

DZKIT

ASSEMBLY, SERVICE & USER'S MANUAL



**POWER CONTROLLER
ADD-ON FOR THE QRP-LABS
QMX+ TRANSCEIVER**

DZ COMPANY CONTACT INFO

Orders, parts, phone assistance(970) 667-2254

Email orders sales@dzkit.com

Email technical support support@dzkit.com

Web site www.dzkit.com

Mail:
DZKit
6151 Panoramic Dr.
Loveland, CO 80537

YOUR DZKIT 1-YEAR LIMITED WARRANTY

During the first year after shipment, DZ Company will replace or repair free of charge—as soon as practical—any parts which are defective, either in materials or workmanship, and any incorrect or missing parts. You can obtain parts directly from DZ Company by writing us, emailing us or telephoning us. And we'll pay shipping charges to get those parts to you—anywhere in the world.

We warrant that during the first year after shipment, our products, when correctly assembled, calibrated, adjusted and used in accordance with our printed instructions, will meet published specifications. Once assembled, if the product fails to operate correctly, we will help you determine which subassembly requires service. If return is found to be necessary, you must then ship that subassembly, or whole unit if applicable, to the address below at your expense, and we will repair or replace it at our option and return it to you at no charge.

You will receive free consultation (except for the cost of your long distance phone call) on any problem you may encounter in the assembly or use of your DZKit product. Just write us, email us, give us a call, or visit our website and click on "Support". That will give you access to free support. Sorry, we cannot accept collect calls.

Our warranty, both expressed and implied, does not cover damage caused by the use of acid-core solder, water-soluble flux solder (without appropriate washing), or any corrosive or conductive flux or solvent, defective tools, incorrect assembly, misuse, fire, customer-made modifications, floods or acts of God, nor does it include reimbursement for customer assembly or setup time. The warranty covers only DZKit products and is not extended to non-DZ allied equipment or components used in conjunction with our products or uses of our products for purposes other than as advertised.

This warranty applies only to the first owner of the product and is not extended to subsequent owners.

This warranty gives you specific legal rights, and you may also have other rights which vary from state to state.

THE DZ COMPANY, LLC
6151 PANORAMIC DR.
LOVELAND, CO 80537

Assembly, Operation and
Troubleshooting

Of the



QMX+ Power Controller

DZ COMPANY
LOVELAND, COLORADO

TABLE OF CONTENTS

Introduction	4
General assembly notes	5
Safety notes.....	8
Soldering instructions.....	9
Static precautions.....	10
Parts identification.....	11
Step-By-Step Assembly.....	12
Theory/Troubleshooting	16
Schematic.....	17



INTRODUCTION

The QRP-Labs QMX+ transceiver is a compact Software-Defined Radio (SDR) transceiver and covers all ham bands from 160 through 6 meters. It can put out about 5 watts of power, but that power level is not adjustable. When connected to an amplifier, it is often desirable to be able to vary the power.

The DZKit QMX+ Power Controller mounts to the QMX+ board, fits inside the optional case and provides a way to control the power level from 0 to full power using an external potentiometer (provided in the kit).

This board is also used in the DZKit Sienna XL 250 Watt transceiver, which uses a QMX+ SDR inside. One notable difference is that Sienna uses a digital pot to control the power level rather than a discrete part.

If you happen to be skilled at writing code to control I2C-based devices, you can add the necessary parts to the board and provide the necessary digital control signals. A description of how to do this is beyond the scope of this manual, but please contact us if you are interested.



General Assembly Notes

1. Screws in this kit are Philips Panhead Machine Screws. For simplicity, we refer to them simply as “screws”.
2. The PC board attaches to the QMX+ circuit board using metric standoffs and M3 screws with locking compound to keep them from working loose.
3. As you tighten a screw, it is very important that you do not strip the threads. All screws should fasten smoothly. If a screw appears to be very hard to fasten, something else is probably wrong—a cable could be in the way, you are trying to use the wrong size screw or something else is wrong. **DO NOT FORCE SCREWS!** Instead, inspect the assembly carefully and try to see why you are having difficulty. Screws with locking compound on them are normally a little harder to fasten.
4. All references to left and right, front and back are with the chassis in an orientation such that the front of the radio faces you.
5. Most electronic kits that are returned for service have poor soldering jobs. **Please** take a moment to familiarize yourself with proper soldering technique. And do not, under **ANY** circumstances, use corrosive (“acid-core”) solder! That will void your warranty and render your kit inoperative. Also be sure to avoid the use of products that may be called solder but are really glue (e.g., LePage's Liquid Solder, nothing more than metallic-grey colored airplane glue).
6. Soldering should only be done in an area with good ventilation and with a properly heated soldering iron.
7. Resistors are identified by their values in Ohms, Kilohms (K) or Megohms (M) and by color codes. Your kit uses resistors of several types. Axial leaded resistors have color coded bands on them. For 5% resistors, the first two bands represent the numeric value and the third band represents a multiplier, which is a power of 10. Thus, a 56 Ohm resistor is Green-Blue-Black. A 10KOhm resistor is Brown-Black-Orange, and so on. The fourth band is the tolerance – no band represents 20%, a silver band 10%, and a gold band 5%. Your kit uses mostly one percent or better resistors, which have 4 bands for the value. A 4.75K resistor is Yellow-Violet-Green-Brown. We normally pre-sort parts in our kits, but since this one only has a few parts, we suggest that you use an volt-ohmmeter to check the values rather than relying on the color

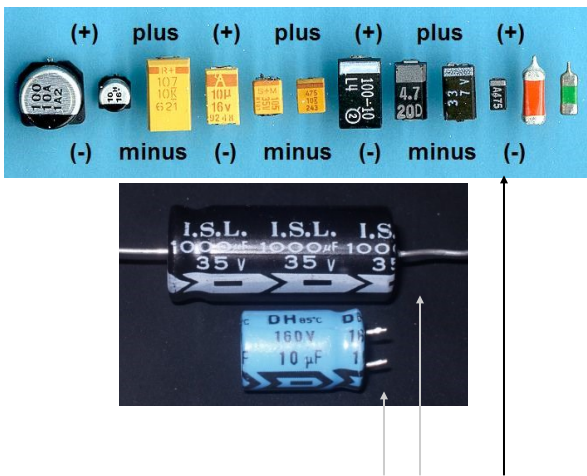
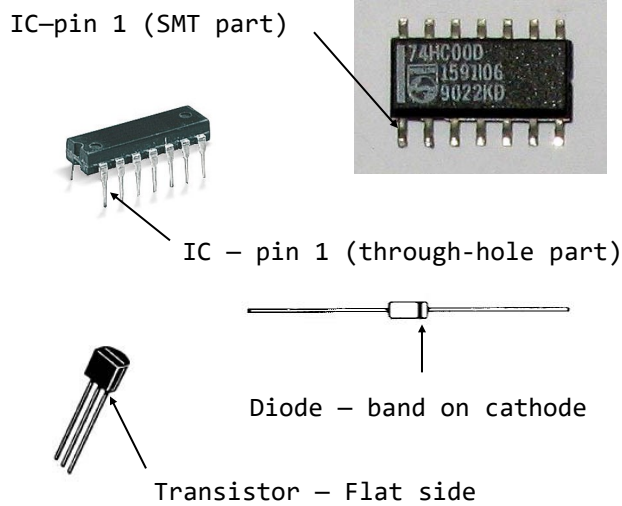

Electrolytic capacitors - negative side

Detail 1. Identifying polarity of diodes, transistors, ICs and polarized capacitors.



codes. A fluorescent light is also useful to “bring out” the colors, and a magnifying glass is also handy.

8. Capacitors are identified by their type – disk, polystyrene, polypropylene, electrolytic, trimmer, etc. – and capacitance values are in microfarads (μF) or picoFarads (pF). Polarized types have the positive pin marked on the silkscreen and also have a square pad.
9. Inductors are represented either by their inductance in nanoHenries (nH), microHenries (μH), milliHenries (mH) or by the number of turns in the coil if you are doing the winding.
10. Diodes are marked with a band on the cathode end. The PC boards have a bar silkscreened across one side of the component outline and a square pad which identifies the cathode.
11. Transistors have either a tab or a flat side that you can match to the silkscreened component outline. Most transistors will need to have their

leads “sprung” a little to fit in the holes. Do so carefully to avoid breaking the leads off.

12. ICs have a notch, beveled side and/or a dot representing the side containing pin 1. When you hold an IC with the notch or the beveled side up, pin 1 is in the upper left corner. The silkscreened outlines on the board all have notches and pin 1 also has a square pad.
13. To insert an IC, rest the IC on its side on a hard surface. Slowly roll the entire chip so that all the leads on that side are bent inward at once and the same distance. Do about half what appears to be required. Check the leads against the socket or PCB and then roll the other side inward the same way.

14. It is CRITICAL that you mount polarized parts correctly! Double check your work to be sure that all such parts match the photos. See Detail 1.



Most kit builders find it helpful to separate the parts into categories for quick identification. Muffin tins and cardboard egg cartons serve this purpose admirably.



Safety First!

Your safety is of utmost importance to us. Please read this information before you get started, and remember these rules as you continue building and testing your kit.

1. **Always have a healthy respect for electricity.** The voltages present can be as high as 14VDC, and high currents are available (up to 2 Amps DC).
2. **When measuring voltages inside electronic equipment,** it is generally a good idea to use only one hand, wear rubber-soled shoes and avoid areas with standing water. However, remember that slightly humid environments can prevent static electricity that could damage the electronic parts! Use a humidifier in dry climates.
3. **Do not work on powered electronics by yourself** if at all possible. Have a parent, spouse or friend nearby. If you must work alone, keep a telephone handy in the event you run into problems.
4. **Soldering irons are hot.** They can burn your skin and cause damage to workbenches and carpets. We recommend you use one with an automatic shutoff in case you forget to turn it off when you are done.
5. **Do not work on electronic projects when you are tired.** We know you want to finish it, but accidents are more likely when you are tired. Take breaks! Be careful!
6. **Use proper ventilation in your work area.** Solder contains tin and lead (or tin and silver), and solder fumes should not be allowed to “hover” near your work. Open a door or window, use a fan, and be cognizant of the potential dangers.
7. **When clipping leads, use eye protection** and/or be sure to direct the flying leads down into a nearby trash can. As you gain experience clipping component leads, you will learn how to clip them so that they fall harmlessly away from the board.
8. **Be careful not to cut yourself** when handling sharp objects such as connectors and sheet metal. Keep some tissues, bandages and antibiotic ointment nearby in the event of an injury.
9. **Use common sense** in dealing with unfamiliar things. If you don't understand something, call us or ask a friend for help.



SOLDERING INSTRUCTIONS

Poor soldering accounts for almost all kit building problems. The photographs below show examples of the most common types of bad solder connections and a good one. If you locate any of these bad solder connections in your kit, correct them as described. Study this section carefully before you start building your kit.

Solder joint problems. Solution: Remove solder with a wick or solder sucker (see below), and re-heat the connection, touching the iron to both the component lead and the pad at the same time.



Use a good quality, variable temperature soldering iron with a conical, narrow tip, and set the temperature to 850 degrees F. We provide 2' of recommended solder in each kit. Keep the sponge damp and wipe the tip on the sponge before each solder step.



Solder bridge.

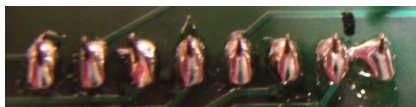

Solder that stretches from one trace or pad to another creates a short circuit. Solution: Hold the board upside down and reheat the area. The excess solder will flow down the soldering iron. Another solution is to use a "solder sucker" or solder wick to remove excess solder. Solder suckers work well one or two times on a given connection. After that, they can lift pads off the board.



Good solder connections. A good solder connection looks like this. Solder flows evenly onto both the part and the PC board or chassis component. It is shiny and even, not lumpy and dull. Component leads that are properly soldered can not be moved in the hole. The component lies flat on the board.

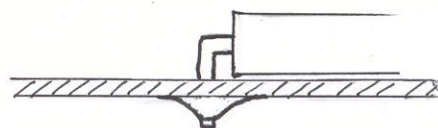



STATIC PRECAUTIONS

Many of the components in your kit can be damaged by exposure to static electricity. Please read this page to familiarize yourself with the causes of and solutions to this problem.

When the climate is dry, you can generate thousands of volts simply by walking across a carpet. When you then touch a metal object you can feel the effects of this as you draw a spark! That same spark, often too small to see or feel, can destroy sensitive electronic components. You **MUST** take precautions when working with electronics to prevent damage.

The best solution is to outfit your workbench with anti-static devices – floormats, grounded soldering irons, and work mats with grounded wrist straps. If these are not practical for you, the very least you should do is to discharge yourself to ground after you sit down and before you touch any electronic items, by touching a grounded object such as the corner of a wall.

In a dry environment, simply standing up after sitting in a non-grounded chair can also charge you with electricity. If you stand up to stretch, for example, be sure to re-ground yourself before getting back to work. Don't wear insulated sole shoes and avoid nylon, wool or other

static-producing material in your clothing.

If your work area floor is carpeted, spray fabric softener on it using a hand spray bottle. Fabric softener is conductive and will bleed away carpet static for a few hours.

Don't use a plastic table unless you have a grounded work mat on it. Use a wood or metal table if possible.

Pets are notorious for inducing static into your work area. Don't allow them anywhere near your workbench!

All electronic components are susceptible to static, but semiconductors and assembled boards containing semiconductors are the most prone to damage. These include diodes (including light-emitting diodes [LEDs]), transistors and integrated circuits (ICs).

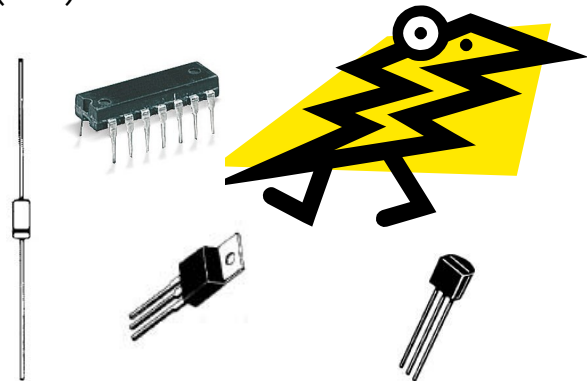

You are a walking lightning bolt! Be careful!



PARTS

Reference Designator(s)	Description	Vendor	Vendor P/N	Stock bin	Qty
C1,C2,C4, C5,C6	Capacitor .1uF MLCC 50V radial X7R 5%	Mouser	80-C320C104K5R	232	5
C3	Capacitor 1uF 50V MLCC MLCC radial 10%	Mouser	810-FG14X7R1H105KRT6	813	1
J1	Connector 6-pin friction lock header straight post tin	Mouser	571-6404566	371	1
L1	Inductor 10uH 1A Leaded Unshielded 1.5A 10%	Mouser	815-AIAP01100KT	683	1
R3	Resistor 10 ohm 1/8W metal film axial 1%	Mouser	708-RNF18FTC10R0	356-10	1
R1,R2	Resistor 100 ohm 1/4W metal film axial 1%	Mouser	708-RNMF14FTC100R	21	2
R4	Resistor 200 ohm 1/8W metal film axial 1%	Mouser	71-RN55D-F-200	356-200	1
R7	Resistor 10K ohm 1/8W metal film axial 1%	Mouser	708-RNF18FTD10K0	356-10K	1
R8	Resistor 12.5K ohm 1/6W metal film axial 1%	Mouser	603-MFR-12FTE52-12K5	356-12.5K	1
U1	IC LMC6482AIN dual op-amp rail to rail DIP	Mouser	926-LMC6482IN/NOPB	653	1
Q1	Transistor MJD122G Power Darlington 8A 100V	Mouser	863-MJD122G	850	1
	Hardware 4-40 x 1/4in PH Phillips M/S SS patchlock	McMaster-Carr	96562A106	479	2
	Hardware 4-40 KEPS nut SS	McMaster-Carr	96278A005	457	2
	Hardware 4-40 x 1/2in Hex M/F Spacer SS	McMaster-Carr	91075A103	852	2
RV1	Resistor variable panel mount 10K Ohm	Mouser	313-1000F-10K	B27	1
CA1	Cable - 6-pin MTA to 6-pin MTA, 8"	DZ			1
	Wire 24 AWG bus wire (bare)	Mouser	566-8022	718	0.17
	No-clean .020" Alpha 143090 Lead-free Solder	Technimark	Alpha 143090	B41	2
	TXALC Board blank	DZ	S0105-20012	750A	1

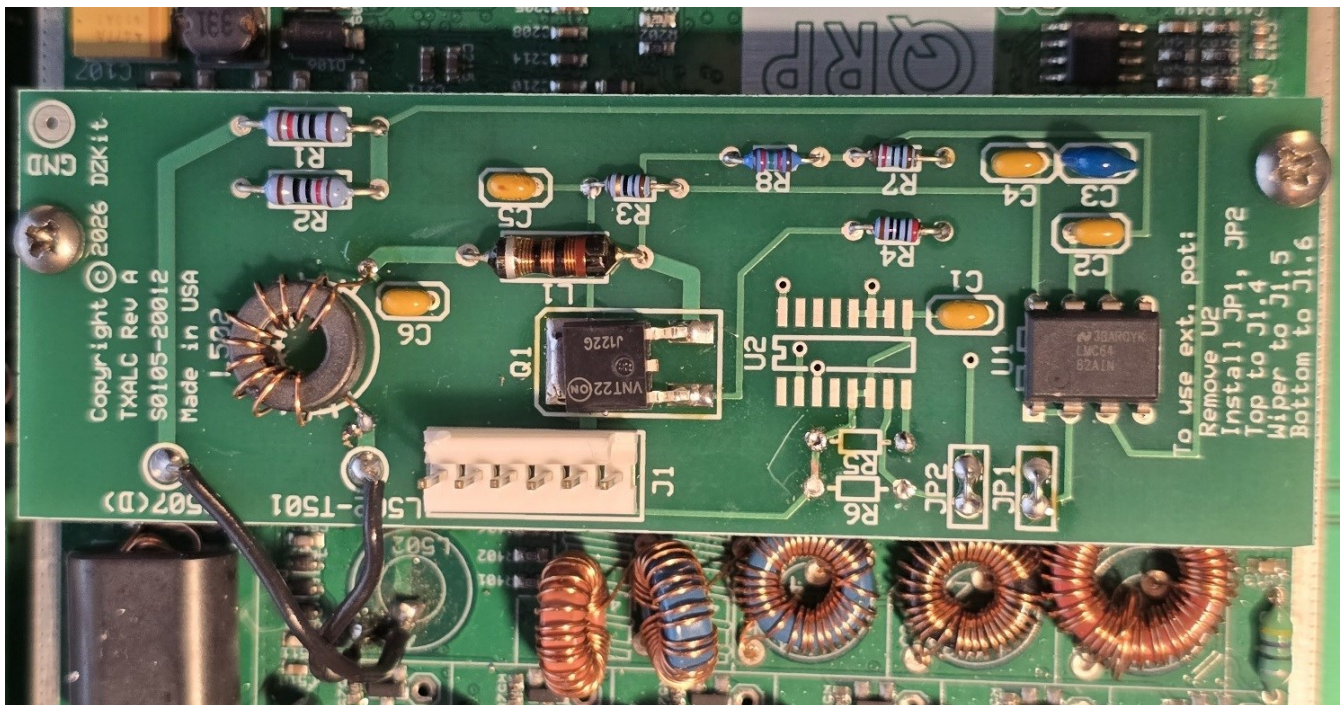



STEP-BY-STEP ASSEMBLY– Power Control Board

Please read all notes on this page before proceeding:

1. Check off each step as you do it.
2. After loading the parts, apply solder to them on the back side of the board, then clip the excess leads using wire cutters.
3. To load resistors, hold a resistor over the holes to see where the leads need to be bent. Bend them sharply using your fingernails. After you do a couple of these, you will understand how far apart to bend the leads.
4. When inserting parts, bend the leads over 90 degrees on the back side of the board to hold them in place. For IC's, if they are loose, just bend one lead in each corner.

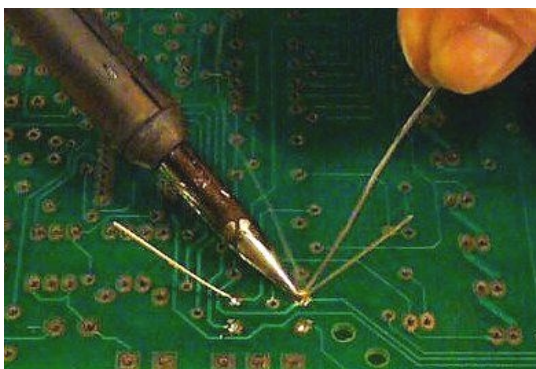

5. Make sure all parts lie flat on the board. If they don't, re-heat them while pushing down.
6. Unlike DZKit's more elaborate kits, the components have not been pre-sorted. Please use an Ohmmeter to measure the values of the resistors and read the values printed on the capacitors.
7. When loading integrated circuits, make sure pin 1 is placed in the square pad. The text printed on the body of the part should read correctly left to right when pin 1 is in the square pad. There is also typically a notch or a bar along that end. See page 7.
8. **DO NOT USE Flux remover or water to clean the circuit board.** The specially formulated solder that is provided with your kit does not require this, and use of cleaners will actually leave a gummy residue.

() I have read all of the above.



STEP-BY-STEP ASSEMBLY— Power Control Board

Note: Solder all connections after completing each step, then clip excess leads. Use the parts list and photo on page 11 to identify the parts. Check off each part on the parts list as you load it.

- () Load and solder resistors R1 and R2 (both 100 ohms, 1/4 watt). These parts are larger than the other resistors. Do not mistake them for L1, the power inductor.
- () Load and solder R3 (10 ohms), R4 (200 ohms), R7 (10K ohms) and R8 (12.5K ohms). (R5 and R6 are not used.) Be sure to measure the resistances before installation.
- () Load and solder all capacitors. Polarity does not matter. The values are printed on the capacitors. Note that C3 is blue, 1uF, while the others are yellow, 0.1uF.
- () Load inductor L1. This part is larger than the other axial parts.
- () Load and solder the IC (U1). Make sure pin 1, marked with a dot, goes in the square pad.
- () Load and solder the surface mount Darlington transistor (Q1). Before loading this part, apply solder to the large square pad on the board. Lay the part down so that it lines up with the pads and solder one of the pins. Once it is in place, solder the other pin. Then apply a liberal amount of solder to the edge of the tab, heating it up until the solder flows under the part. Push the part down with a tool (Don't use fingers—it gets hot!) and hold it until the solder dries.
- () Load and solder the white "MTA" connector. It must be inserted so that the tab on the back of the connector lines up with the thick bar on the silkscreened outline.
- () Cut the 2" length of bare wire in half and solder each piece into the pads labeled JP1 and JP2.
- () Note that U2 is not loaded. This is used when the board is mounted to a QMX+ that is located inside the DZKit Sienna XL 250W transceiver.
- () Remove the QMX+ main circuit board from its chassis.
- () Remove toroid L502 from the QMX+ and solder it where marked on the Power Control board.
- () Inspect your work. Look for shorted pads, unsoldered parts, backwards parts, unclipped leads, etc. Compare your board to the picture on page 11. Fix any defects.



STEP-BY-STEP ASSEMBLY– Power Control Board

- () Install the two hex standoffs to the QMX+ where noted, using two 4-40 x 1/4" screws on the bottom of the QMX+.
- () Replace the QMX+ main board in the chassis.
- () Place the Power control board on top of the standoffs with components facing up, and secure it with two 4-40 KEPS nuts. It can only be installed one direction.
- () Push the cable assembly onto connector J1. It will only go on one way.
- () Twist the three wires on pins 4, 5 and 6 of the cable assembly together, approximately 1 turn per inch, and feed them out of any available opening on the back of the QMX+. The "Aux" or "GPS" connector openings can be used for this if available. Aux is a serial TTL interface that you may not need, since the QMX+ is normally controlled via its USB connector. If the desired connector is present, first remove it from your QMX+.
- () Clip and save 3" of excess wire from the longer (brown) wire so that all three wires are the same length.
- () Cut the 3" wire you just removed into two pieces. Strip and tin only one end of each wire. Twist the other ends as tightly as possible and test fit them in the two pads located near L502 on the Power Control board. Solder these untinned leads to the pads marked Q507(D) and L502-T501.
- () Connect the other end of the wire that goes to Q507(D) to the pad in the center of the toroid outline marked on the QMX+ circuit board. This pad goes to the drain of transistor Q507 on the QMX+.
- () Connect the other end of the wire that goes to L502-T501 to the other L502 pad on the QMX+ circuit board. Note that because of the way the board had to be laid out, these two wires cross as they connect to the QMX+ board. These connections are NOT reversible!
- () Connect the red wires (pins 1 and 2) on the connector to your switched power inside the QMX+. A convenient spot is the source of Q507:

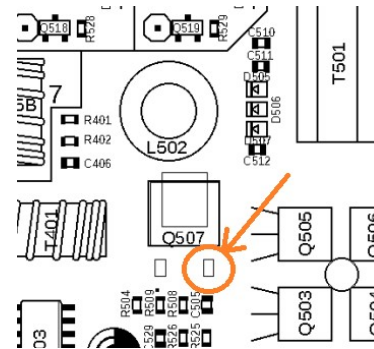

- () The pad marked "GND" is not used, but can serve as a convenient ground reference when measuring voltages.



STEP-BY-STEP ASSEMBLY - Final Assembly

- () Mount the potentiometer to any convenient place external to the QMX+. Strip and tin the three wires that you previously routed through a QMX rear panel opening. Twist these wires about 1 turn per inch.
- () Solder the green wire to either end lug, white wire to the center lug and the brown wire to the other lug. About 9" of wire was provided. You can extend these if desired by soldering additional wire to the ends and either taping them or using heatshrink tubing.
- () Apply power to the DC input jack of your QMX+ and a dummy load to the antenna jack, and turn it on. Key the rig. As you turn the pot, the power level will be changed. You can verify this by connecting an RF power meter to your rig.
- () Put the case back together.

This completes assembly of your DZKit Power Control Board for the QRP-Labs QMX+ SDR.



THEORY OF OPERATION/TROUBLESHOOTING

The Power Control board replaces L502 in the QMX+ with a circuit that varies the voltage to the final transistors in the QMX+, thus changing the power level.

Note that a simple pot will not work here, because the impedance of this part of the circuit is very low to allow the drive current to pass through to the final transistors, so it is not practical to simply attenuate the voltage with a series pot.

The voltage on the drain of Q507 is divided by two through resistors R1 and R2, then buffered by op-amp U1. The output of the op-amp is then attenuated by the external pot. The attenuated voltage is then amplified by the other half of U1 and fed into a Darlington transistor which provides high current with low loss to the final transistors. The emitter of the transistor is fed back to the op-amp through R8, making the gain $1 + 12.5/10 = 2.25$. This brings the level back up to the original drain voltage of Q507. The extra gain is needed to compensate for the voltage drop of about 1.4V through the emitters of the Darlington transistor.

L1 and C1 provide a filter to prevent oscillation. The resulting output is fed to the QMX+ finals.

When used as a standalone power control board for the QMX+, the external pot controls the power level. When used inside a Sienna XL transceiver, this pot is removed, U2 is loaded, the jumpers are removed, and the pullup resistors, R5 and R6, on the I2C control bus are installed. U2 is a digital pot that is controlled via an I2C port in Sienna.

If the circuit fails to work correctly, check these voltages:

U1 pin 8 and Q1 collector (large pad): Same as the voltage going into your QMX+, typically 12V.

L1: Should have approximately the same as the input voltage when the rig is keyed.

If these voltages are not correct, double check solder connections and part polarities, and make sure the two wires that replaced the toroid are going to the correct pads on the QMX+.



SCHEMATIC

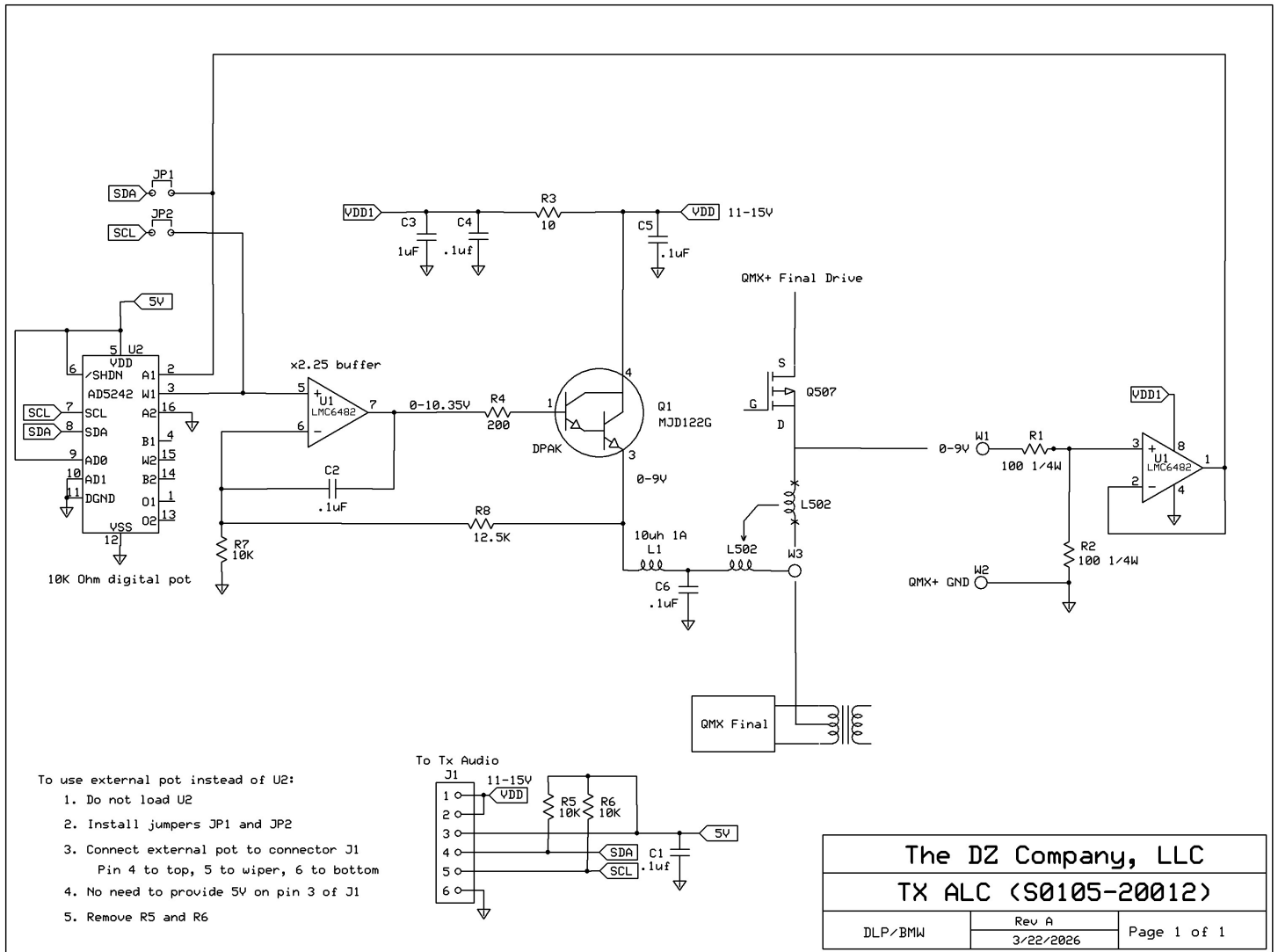





DZ COMPANY

LOVELAND, COLORADO

UNIQUE ELECTRONIC EQUIPMENT IN KIT FORM