

PRICE: \$30.00

DZ COMPANY · LOVELAND, COLORADO

DZKIT

ASSEMBLY MANUAL



SIENNA
HF RECEIVER/TRANSCEIVER

DZ COMPANY CONTACT INFO

Orders, parts, phone assistance(970) 667-2254

Email orders sales@dzkit.com

Email technical support support@dzkit.com

Web site www.dzkit.com

Mail:

DZKit

4321 W. Eisenhower Blvd.

Loveland, CO 80537

YOUR DZKIT 90-DAY FULL WARRANTY

During your first ninety (90) days of ownership, DZ Company will replace or repair free of charge—as soon as practical—any parts which are defective, either in materials or workmanship. You can obtain parts directly from DZ Company by writing us, emailing us or telephoning us. And we'll pay shipping charges to get those parts to you—anywhere in the world.

We warrant that during the first ninety (90) days of ownership, our products, when correctly assembled, calibrated, adjusted and used in accordance with our printed instructions, will meet published specifications.

You will receive free consultation (except for the cost of your long distance phone call) on any problem you may encounter in the assembly or use of your DZKit product. Just drop us a line, email us, give us a call, or visit our website and click on "Support". That will give you access to free on-line support and a discussion group. Sorry, we cannot accept collect calls.

Our warranty, both expressed and implied, does not cover damage caused by the use of corrosive solder, defective tools, incorrect assembly, misuse, fire, customer-made modifications, floods or acts of God, nor does it include reimbursement for customer assembly or setup time. The warranty covers only DZKit products and is not extended to non-DZ allied equipment or components used in conjunction with our products or uses of our products for purposes other than as advertised.

If you are ever dissatisfied with our service—warranty or otherwise— or our products, please write or email the president, Brian Wood, W0DZ, and he will make certain your problems receive prompt, personal attention.

THE DZ COMPANY, LLC
LOVELAND, CO 80537

Assembly

Of the



Sienna HF Receiver/Transceiver



DZ COMPANY
LOVELAND, COLORADO

Copyright © 2011
The DZ Company, LLC
All rights reserved

11-30-11

Sienna

TABLE OF CONTENTS

Introduction	4
General assembly/safety notes	6
Step-By-Step Assembly	
Chassis, DC power, PC, Tuner ...	14
Initial tests.....	34
Front Panel integration	36
Front Panel tests.....	48
Receiver Integration	50
Receiver alignment/test	59
Transmitter integration	68
Transmitter resistance/voltage....	70
Transmitter alignment/tests	72
100W PA Integration	78
100W PA alignment/tests.....	81
Final assembly	84
Appendix A: PC Power Wiring	86
Appendix B: RS232 Board.....	90
Appendix C1: DCD: Power	92
Appendix C2: DCD: SWR	100
Appendix C3: DCD: Tuner.....	102
Appendix D1: Blank Front Panel ..	106
Appendix D2: Full Front Panel	108
Appendix E: IF Filter Board.....	112
Appendix F: RXBPF Board.....	118
Appendix G: Receiver Board	126
Appendix H: Transmitter Board	134
Appendix I: TXBPF Board.....	145
Appendix J: 100W PA Board.....	148
Appendix K: Installing Filters.....	159
Appendix L: IF Test Procedure.	163
Appendix M: RXBPF Test Proc	167



INTRODUCTION

The Sienna family of receivers/transceivers represents a revolution in amateur radio. Now you can start with a relatively inexpensive remote-control-only receiver, using either your own or an internal "embedded" PC to control it using your favorite software, and then add a front panel, transmitter, tuner and amplifier, as well as numerous IF filters as your desires or budget allow. Or you can start with any combination of modules to create just the right radio for your needs.

The time-tested triple-conversion receiver design assures general coverage receive with no dead spots and excellent image rejection. It also has very good dynamic range by virtue of an optional 5KHz roofing filter at the 70.455MHz first IF, and compatibility with a wide variety of high performance crystal filters and Collins mechanical filters at

the 2nd and third IF's to provide excellent selectivity. We've also added innovations in AGC control, bandpass filtering with GaAsFET switches instead of PIN diodes, and the ability to run full-duplex and cross-band at HF frequencies.

Sienna transceivers are also a study in duality: dual preamps, dual keying (manual and paddle inputs available at the same time), dual audio (headphones and speakers available at the same time), dual receive (front panel access to the audio from an external secondary receiver), and dual backlit analog meters, which give the rig a nice glow that harkens back to the early days of radio when all radios glowed. Dual microprocessors are in total control of the radio.

And now, for the first time, with an *optional* internal PC, it is



possible to connect a keyboard, mouse and display to your transceiver and add digital modes, logging, rig control, file transfer via LAN or USB and much more, at a reasonable price, and without adding any external rig interface equipment. It accomplishes this by means of a tiny but powerful personal computer that runs a common operating system—Microsoft® Windows® XP Embedded or Linux. This “embedded PC” is a fully functional personal computer with O/S stored on Compact Flash. It also has on-board sound card, Ethernet networking, COM ports, VGA display, PS/2 keyboard/mouse, USB and more. And it’s expandable, with plug-in MIO boards that offer even more features, such as dual display and 6 Watt stereo speaker outputs.

But unlike some “Software-defined radios” that are totally con-

trolled by PCs, the Sienna does not *need* the PC unless you choose to operate it without its optional front panel. Sienna is a full-featured HF radio. The twin microprocessors in Sienna’s controller run the radio. There’s no waiting for the PC to boot when you turn the radio on unless you want to use the features *added* by the PC.

The Sienna can be built in several stages and in several combinations. This manual is thus a complete assembly manual for the fully loaded Sienna. As you upgrade your Sienna, you can still use this one manual as a complete assembly reference.

Thanks for trusting in DZKit to provide not only unique electronic products, but to give you hours of building fun too.



General Assembly Notes

1. Most screws in this kit are Phillips Panhead Machine Screws. For simplicity, we refer to them simply as “screws” unless a different style is used. These may be stainless steel or zinc-plated steel.
2. Almost all sheet metal parts are attached to each other using 6-32 x 1/4” screws that are inserted into captive fasteners that have been pressed into the sheet metal by the factory. You will not need to use many nuts and lockwashers.
3. Most PC boards attach to the sheet metal using 6-32 x 1/4” screws but there are some exceptions, which are explained in the steps.
4. As you tighten a screw, it is very important that you do not strip the threads. All screws should fasten smoothly without resistance. If a screw appears to be hard to fasten, something else is probably wrong—a cable could be in the way, you are trying to use the wrong size screw or something else is wrong. **DO NOT FORCE SCREWS!** Instead, inspect the assembly carefully and try to see why you are having difficulty.
5. A PC within arms reach of your workbench is useful in helping you locate the parts on the boards. Shipped with your kit is a USB flash drive containing the PCB layout files for all boards (without traces). To find the location of a part, simply install and run the “ExpressPCB” program (free download from www.expresspcb.com) and open the board you wish to work on. Press “Ctrl-F” to find a part, and then enter it in the box that pops up (e.g., “R1”, without the quotes). The program will show you exactly where that part is located. If you do not have a PC nearby but have ordered the internal PC for the Siena, you can run this program on it once you have installed the PC (which is done in an early step). Take a few minutes to familiarize yourself with this program before beginning construction. You can also find parts manually by just looking for the part on the silkscreen, but on the denser boards, this can take a long time. We highly recommend using ExpressPCB to locate parts.
6. There are three large sheet metal brackets. Two are identical and are placed opposite each other lengthwise from front to back. These brackets are referred to as “large bracket LR” (for Left/Right). The other large bracket runs from side to side in the



front, attaching to the other brackets. It is called the "front bracket".

7. All references to left and right, front and back are with the chassis in an orientation such that the front of the radio faces you. The large openings on the bottom of the chassis are to the right, with the folded sides pointed up.
8. Each circuit part has its own component number (R1, L4, Q3, etc.). R1 on one assembly will not be the same as R1 on a different assembly, so be sure you are looking at the right set of parts when comparing part numbers with the printed parts list. Check off each part at the beginning of each section to make sure all the parts are there. If you find any missing, give us a call or email us and we will rush a replacement to you.
9. Most electronic kits that are returned for service have poor soldering jobs. **Please** take a moment to familiarize yourself with proper soldering technique. And do not, under **ANY** circumstances, use corrosive ("acid-core") solder! That will void your warranty and render your kit inoperative. Also be sure to avoid the use of products that may be called
- solder but are really glue (e.g., LePage's Liquid Solder (nothing more than metallic-grey colored airplane glue).
10. Soldering should only be done in an area with good ventilation and with a properly heated soldering iron.
11. Resistors are identified by their values in Ohms, Kilohms (K) or Megohms (M) and by color codes. Your kit uses resistors of several types. Axial leaded resistors have color coded bands on them. For 5% resistors, the first two bands represent the numeric value and the third band represents a multiplier, which is a power of 10. Thus, a 56 Ohm resistor is Green-Blue-Black. A 10K Ohm resistor is Brown-Black-Orange, and so on. The fourth band is the tolerance – no band represents 20%, a silver band 10%, and a gold band 5%. Your Sienna uses mostly one percent or better resistors, which have 4 bands for the value. A 4.75K resistor is Yellow-Violet-Green-Brown. We have placed resistors of given types in individual bags for you, but should they get mixed and you have trouble reading the color code, we recommend an inexpensive volt-ohmmeter be used to check the values. A

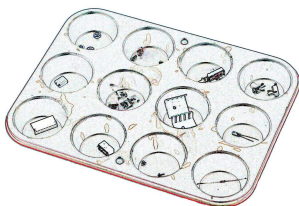

Most kit builders find it helpful to separate the parts into categories for quick identification. Muffin tins and egg cartons serve this purpose admirably.



fluorescent light is also useful to “bring out” the colors, and a magnifying glass is also handy.

12. Capacitors are identified by their type – disk, polystyrene, polypropylene, electrolytic, trimmer, etc.) and capacitance values are in microfarads (uF) or picoFarads (pF). Polarized types have the positive pin marked on the silkscreen and also have a square pad.

13. Inductors are represented either by their inductance in nanoHenries (nH), microHenries (uH), milliHenries (mH) or by the number of turns in the coil if you are doing the winding.

14. Diodes are marked with a band on the cathode end. The PC boards have a bar silkscreened across one side of the component outline and a square pad which identifies the cathode.

15. Transistors have either a tab or a flat side that you can match to the silkscreened component outline. Most transistors will need to have their leads “sprung” a little to fit in the holes. Do so carefully to avoid breaking the leads off.

16. ICs have a notch, beveled side and/or a dot representing the side containing pin 1. When you hold an IC with the notch pointing up or the beveled side to your left, pin 1 is in the upper left corner. The silkscreened outlines on the

board all have notches and pin 1 also has a square pad.

It is CRITICAL that you mount polarized parts correctly! Double check your work to be sure that all such parts match the photos. See Detail 1.

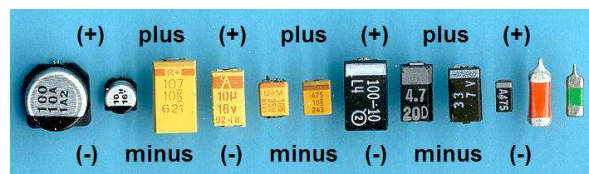
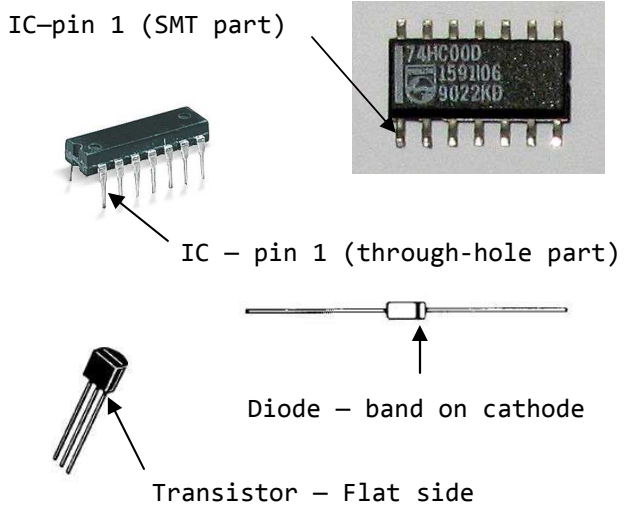

De-tail 1.
Electrolytic capacitors – negative side

Identifying polarity of diodes, transistors, ICs and polarized capacitors.



Abbreviations and definitions of terms used in this manual:

PC = Personal Computer
PCB = Printed Circuit Board
PH = Panhead
FH = Flathead
M/S = Machine Screw
PCB-mt = Printed Circuit Board mounting
AMP MTA = Tyco Electronics connector with .1" or .156" pin spacing
IDC = Insulation Displacement Connector (MTA connectors are IDC type)
Ribbon cable = Flat, gray cable with connectors on each end
Header = PCB-mounted connector
CA = Cable Assembly

A word about what lies ahead...

This manual is designed to allow you to build confidence in your kit-building ability as you go along. You start by building the DC power distribution circuitry, which is the simplest of all the circuitry. You then install this board on the chassis. You will then be able to turn on the power and measure some voltages. If you purchased the PC, you will then install it, build and attach its DC power supply, power it up and see it boot. This will give you confidence that the kit-building is progressing normally. You will also be able to use the PC to help you locate parts on the rest of the boards using the PCB layout files that we have included. The project continues with building of the front panel circuit board (if you purchased a front panel) and integration with the pre-assembled controller board. At that point, you will be able to experiment with the front panel controls and/or the remote control functions. Once all that works, you will build and install the receiver's IF and bandpass filter boards. Next you will finish building the partially pre-assembled receiver. At this point, you will be able to test and align the receiver and use the built-in keyer. If you purchased the base Sienna model, which is a receiver, you're done! Otherwise, you might want to take a break and spend a few hours using the receiver before continuing! Next, you will finish the partially assembled transmitter. The transmitter and receiver boards are the most complex, which is why they have been saved for last. But once you get to them, you will have great confidence that you have built the radio correctly to that point. So let's get started!

NOTE: If you would prefer to build all the boards first, you may go directly to the Appendices and do so.



KIT-BUILDING PROCEDURES

The steps involved in building a kit are listed below. Be sure to follow them and you will have a lot of fun building, aligning, testing and using your kit.

1. **Do a parts inventory.** At each major section and in the Appendices, there's a list of parts used in that section (or that will be used shortly). Check off each part to be sure you are not missing anything. Our method of bagging parts is different from all other kit vendors and will make the task much faster and less error prone. But despite our valiant efforts, mistakes can happen. If you are missing any parts, call or email us and we'll rush replacements to you immediately.
2. **Do not remove parts from the bags until called for,** to avoid mixing parts up (especially resistors).
3. **Pay attention to soldering techniques.** Keep your soldering iron clean by using a wet sponge, use appropriate heat and maintain heat long enough to make good solder joints. Solder problems are the number one cause of problems when building electronic products (not just kits!), so try extra hard to do it right.
4. **Some boards have been pre-loaded with surface mount parts. Be careful not to flex these boards to avoid having parts snap off.**
5. **Take your time!** We know you want to get it done and start using it, but doing it wrong will only delay that moment. Before you start, set up a ventilated, static-free work area with enough room to build the kit. Prepare parts bins and get the tools you will need (needle-nose pliers, wire-cutter, wire stripper, Phillips head screw drivers, wrenches, soldering iron, solder, insulated tool, awl or other sharp-ended tool, scissors, magnifying glass, etc.) Open bags only when they are called for so parts don't get inter-mixed. If you're tired, take a break. Enjoy building your kit!
6. **Make sure that you are loading the part that's called for in the right holes.** Once loaded, it can be hard to find a misloaded part. Be especially careful to load polarized parts (ICs, diodes, electrolytic capacitors) the right direction. If you are not sure about any step, call or email us!
7. **Once you've done a step, put a checkmark inside the parentheses.**
8. **After you have assembled a circuit board, take a moment (just one) to marvel at your handiwork, then spend a few more minutes critiquing it!** Check for solder bridges, unsoldered or insufficiently soldered connections, solder blobs (especially on insulated magnet wire used on toroids), loose screws and electronic parts, reversed polarized components, etc. Sometimes it helps to have a friend check your work.



Safety First!

Your safety is of utmost importance to us. Please read this information before you get started, and remember these rules as you continue building and testing your Sienna.

1. Always have a healthy respect for electricity. While the voltages present inside the Sienna are not lethal, high currents are available (up to 30 Amps when the 100 Watt amplifier is used). Use a power supply with overcurrent foldback or crowbar protection so that in case of high currents the supply will shut down. Set the output current only as high as necessary for a given step.
2. When measuring voltages inside electronic equipment, it is generally a good idea to use only one hand, wear rubber-soled shoes and avoid areas with standing water. However, remember that slightly humid environments can prevent static electricity that could damage the electronic parts! Use a humidifier in dry climates.
3. Do not work on powered electronics by yourself if at all possible. Have a parent, spouse or friend nearby. If you must work alone, keep a telephone handy in the event you run into problems.
4. Soldering irons are hot. They can burn your skin and cause damage to workbenches and carpets. We recommend you use one with an automatic shutoff in case you forget to turn it off when you are done.
5. Do not work on electronic projects when you are tired. We know you want to finish it, but accidents are more likely when you are tired. Take breaks! Be careful!
6. Use proper ventilation in your work area. Solder contains tin and lead (or tin and silver), and solder fumes should not be allowed to “hover” near your work. Open a door or window, use a fan, and be cognizant of the potential dangers.
7. When clipping leads, use eye protection and/or be sure to direct the flying leads down into a nearby trash can. As you gain experience clipping component leads, you will learn how to clip them so that they fall harmlessly away from the board.
8. Be careful not to cut yourself when handling sharp objects such as connectors and sheet metal. Keep some tissues, bandages and antibiotic ointment nearby in the event of an injury.
9. This may sound obvious, but do not insert any parts in any portion of your body.
10. Use common sense in dealing with unfamiliar things. If you don't understand something, call us or ask a friend for help.



SOLDERING INSTRUCTIONS

Poor soldering accounts for almost 90% of all kit building problems.

The photographs below show examples of the most common types of bad solder connections and a good one. If you locate any of these bad solder connections in your kit, correct them as described. Study this section carefully before you start building your kit.

Solder blob. In this example, solder flowed onto a lead, but the heat was not maintained long enough for it to flow onto the circuit board pad. Solution: re-heat the connection, touching the iron to both the component lead and the pad at the same time.



Use a good quality, variable temperature soldering iron with a conical, narrow tip, and set the temperature to 750 degrees F. Use thin, non-corrosive, rosin core solder to assemble your kit. Keep the sponge damp and wipe the tip on the sponge after each solder step.

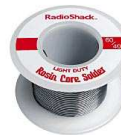

Solder bridge. Solder that stretches from one trace or pad to another creates a short circuit. Solution: Hold the board upside down and reheat the area. The excess solder will flow down the soldering iron. Another solution is to use a "solder sucker" or solder wick to remove excess solder. Solder suckers work well one or two times on a given connection. If used too much, they can pull pads and traces off of PC boards.

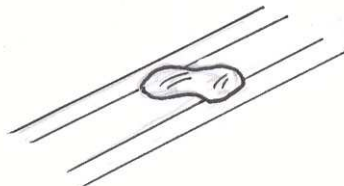

Good solder connections. A good solder connection looks like this. Solder flows evenly onto both the part and the PC board or chassis component. It is shiny and even, not lumpy and dull. Component leads that are properly soldered can not be moved in the hole. The component lies flat on the board.

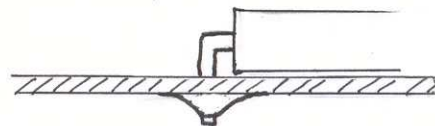



STATIC PRECAUTIONS

Many of the components in your kit can be damaged by exposure to static electricity. Please read this page to familiarize yourself with the causes of and solutions to this problem.

When the climate is dry, you can generate thousands of volts simply by walking across a carpet. When you then touch a metal object you can feel the effects of this as you draw a spark! That same spark, often too small to see or feel, can destroy sensitive electronic components. You **MUST** take precautions when working with electronics to prevent damage.

The best solution is to outfit your workbench with anti-static devices – floormats, grounded soldering irons, and workmats with grounded wriststraps. If these are not practical for you, the very least you should do is to discharge yourself to ground after you sit down and before you touch any electronic items, by touching a grounded object such as the corner of a wall.

In a dry environment, simply standing up after sitting in a non-grounded chair can also charge you with electricity. If you stand up to stretch, for example, be sure to re-ground yourself before getting back to work. Don't wear insulated sole shoes and avoid nylon, wool or other

static-producing material in your clothing.

If your work area floor is carpeted, spray fabric softener on it using a hand spray bottle. Fabric softener is conductive and will bleed away carpet static for a few hours.

Don't use a plastic table unless you have a grounded workmat on it. Use a metal table if possible.

Cats are notorious for inducing static into your work area. Don't allow them anywhere near your workbench!

All electronic components are susceptible to static, but semiconductors and assembled boards containing semiconductors are the most prone to damage. These include diodes (including light-emitting diodes [LEDs]), transistors and integrated circuits (ICs).

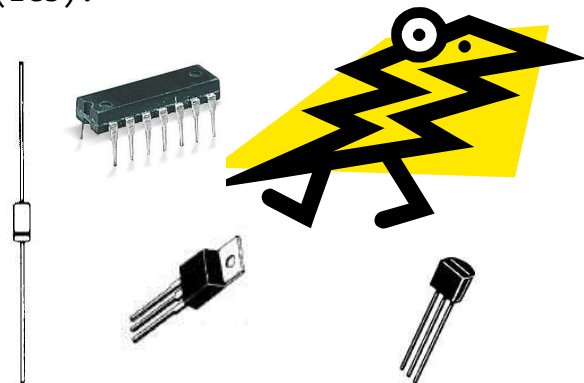

You are a walking lightning bolt! Be careful!



Chassis Parts

Item	Description	Qty	Bag Nr
1	SO-239 RF chassis-mt connector	2	1
2	Phono connector, chassis mount, red	1	1
3	BNC connector, chassis mount	1	1
4	Gas discharge tube	3	1
5	Anderson Powerpole mounting clamp	1	1
6	Foot - front SCREW-ON BLK 1.00 X .75"	2	1
7	Foot - rear SCREW-ON BLK .28 X .625"	2	1
8	Plastic Board Guide - 6"	1	1
9	Screw - 6-32 x 1/4" PH Phillips thread-cutting self-tapping	4	1
10	Screw - 6-32 x 1/4" FH Phillips Black M/S	11	1
11	Screw - 6-32 x 1/4" PH Phillips M/S	55	1
11	Screw - 6-32 x 1/2" PH Phillips M/S	17	1
11	Screw - 6-32 x 1" PH Phillips M/S	2	1
12	Screw - 10-32 x 5/8" PH Phillips M/S	1	1
13	Jackscrew - 4-40 x 3/16" x 3/16" x Male thread = 5/16"	2	1
14	Hex M/F spacer - 6-32 x 1/2"	2	1
14	Hex M/F spacer - 6-32 x 5/8"	12	1
15	Hex F/F spacer - 6-32 x 2"	1	1
16	Washer, flat - #10	2	1
17	Nut - 6-32 KEPS	20	1
17	Nut - 10-32 KEPS	1	1
18	Nut - 10-32 Wingnut	1	1
19	#10 solder lug	1	1
20	Washer - #6 x .050" flat Plastic	1	1
21	Hole plug - .5" nylon	1	1
22	Angle bracket 6-32 threads	5	1

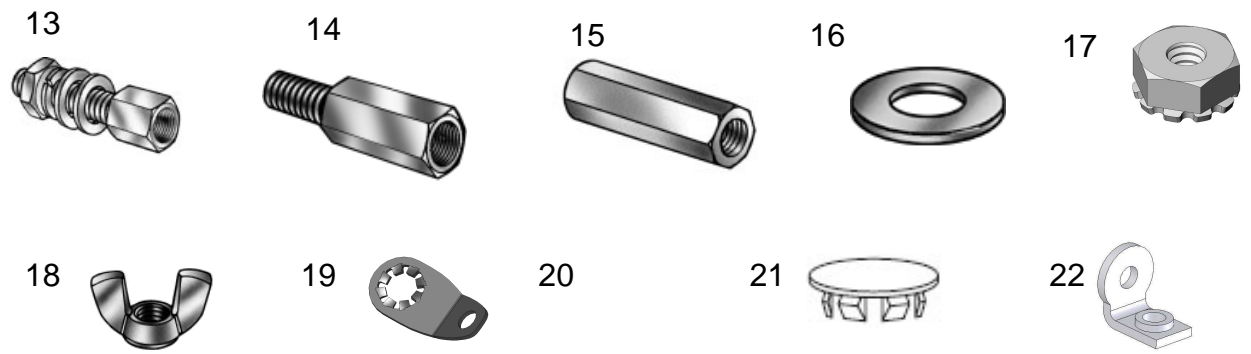
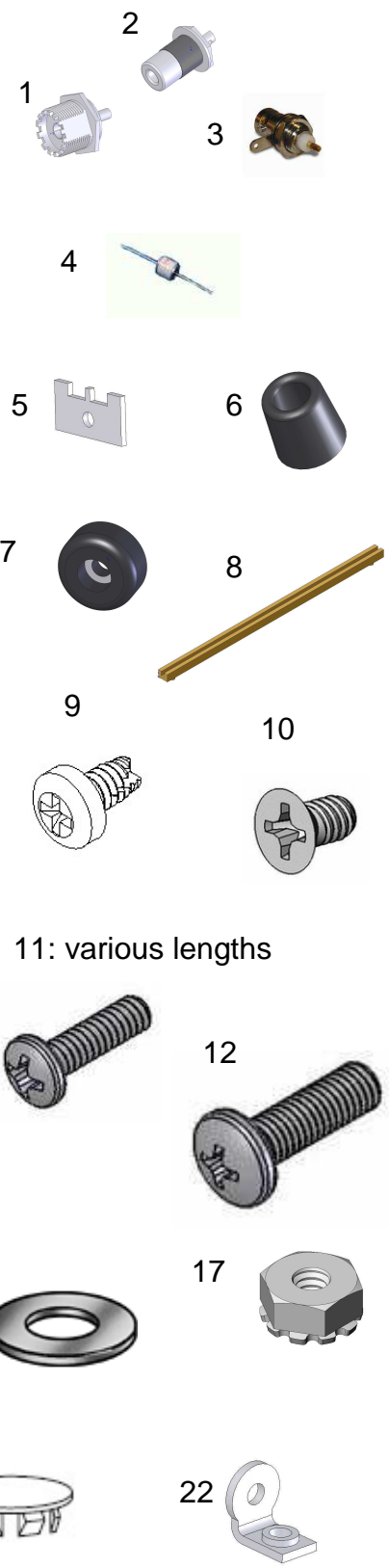



Item	Description	Qty	Bag Nr
	Bare wire 18AWG (inches)	6	1
	Hookup wire - white 24# (inches)	12	1
	Heat shrink tubing, 3/32" x 6"	1	1
	Heat shrink tubing, 1/8" x 4"	1	1
23	Sienna serial number sticker	1	2
24	Fan - 12V 60x60x25	2	
25	Bottom cover plate	1	
26	Chassis bottom	1	
27	Speaker	2	
28	Finger guard—metal	2	1
29	Finger guard—plastic	2	1
30	EMI shield—metal	2	1

23



24



25

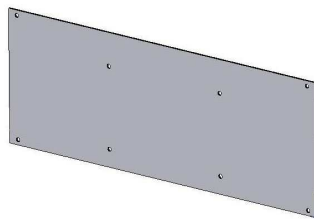

26

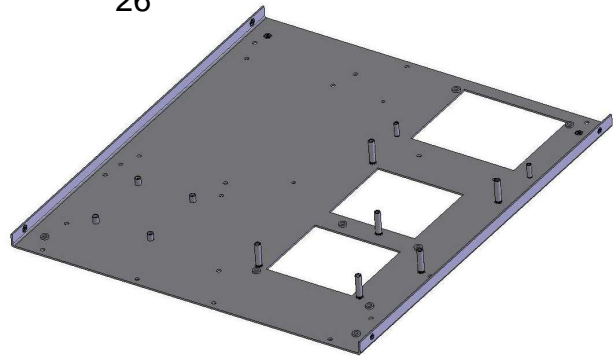

27

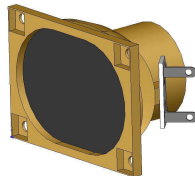

28



29



30

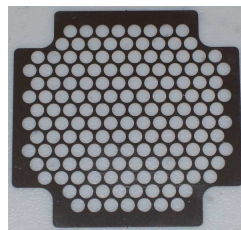



Item	Description	Qty
31	Large Bracket Front	1
32	Large Bracket LR	2
33	Small Bracket	1
34	Exhaust plate	1
35	Rear Panel	1
36	Rear Panel Tray	1
37	PC cover plate	1
38	Top cover	1

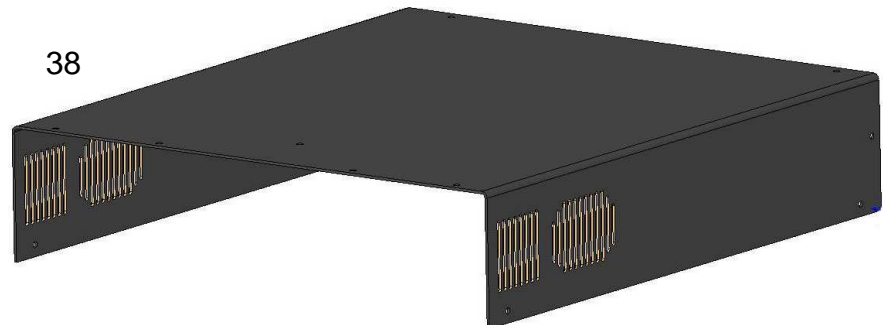
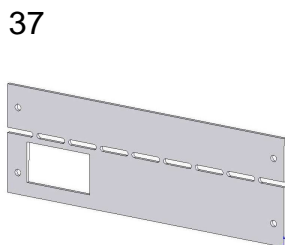
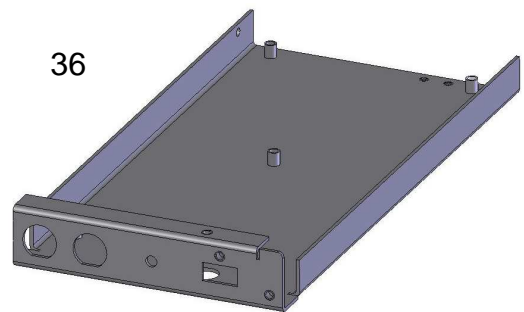
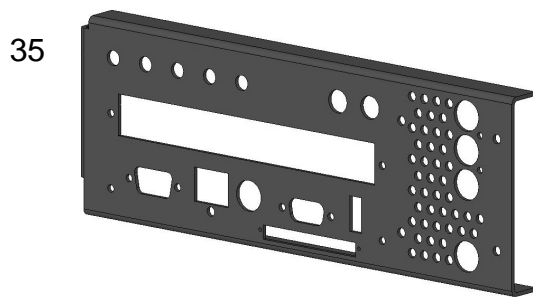
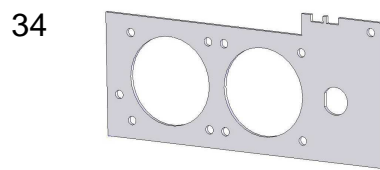
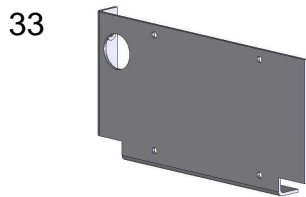
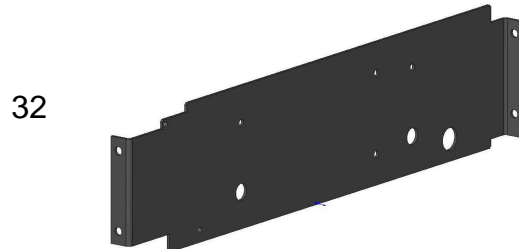
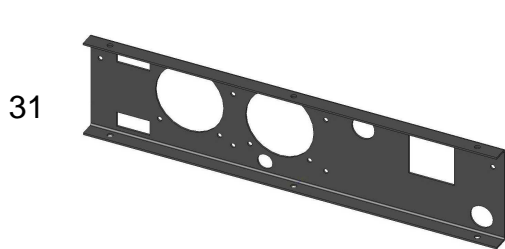



Boards:

Controller (assembled)
DCD/Tuner
IF Filter
RXBPF
Receiver (partially assembled)
RS-232

Options:

Front Panel
Transmitter & SWR Meter (partially assembled)
TXBPF (partially assembled)
100W amplifier
Antenna Tuner
PC (assembled)



Cables

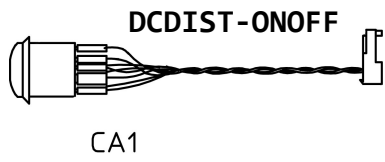

CA-APP DC power input

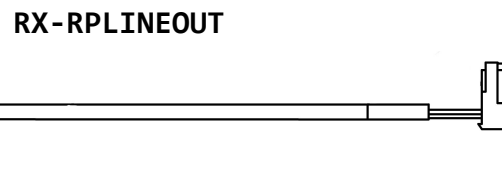
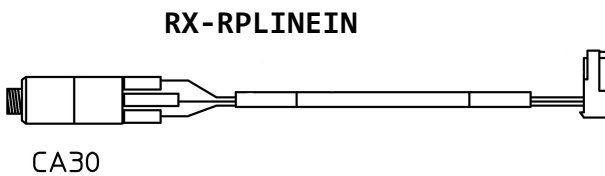
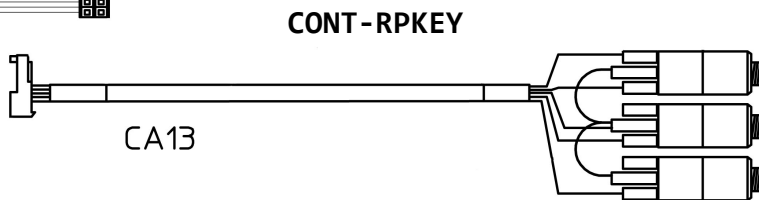
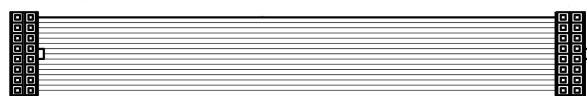
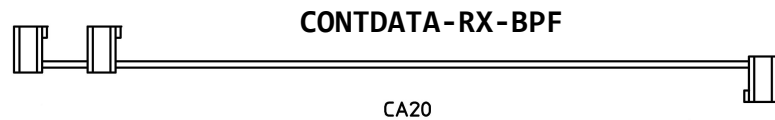
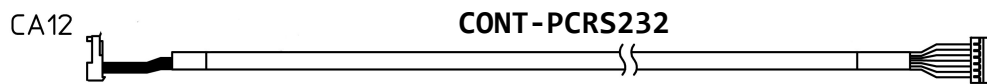



CONT-MIC

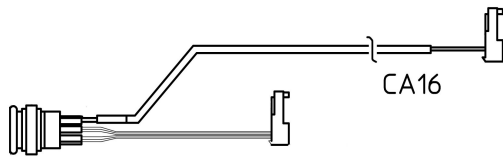

RX-HP

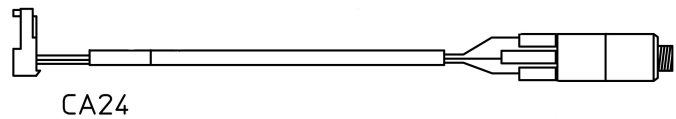

AMP MTA-MTA Cables

Use:

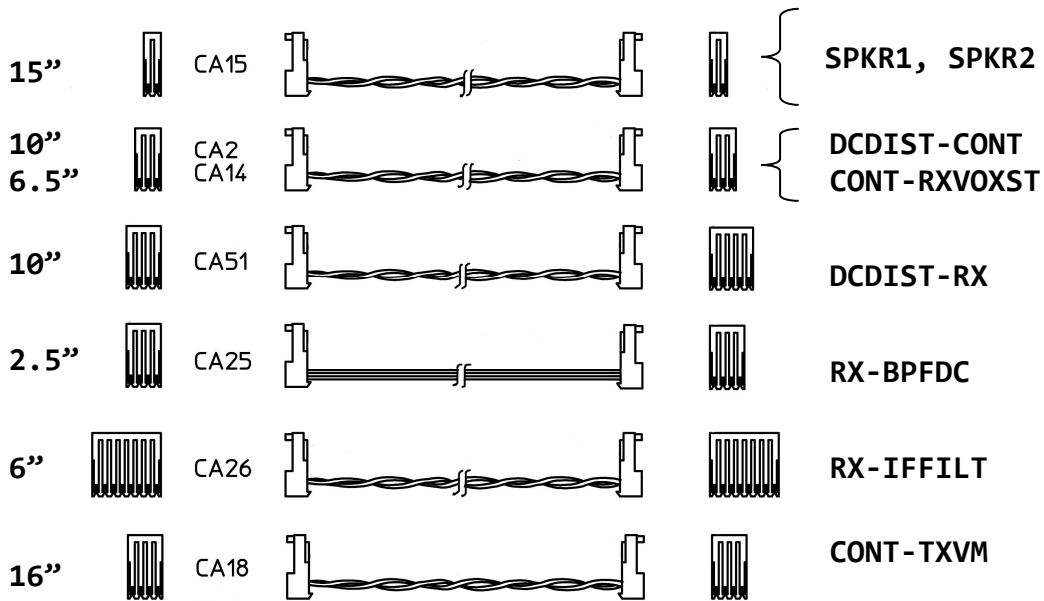

RF CABLES

CA33	RXBPFMAIN-TX/AMP
CA34	RXANT
CA35	RF1 (RXBPF to RX)
CA36	RXLO1
CA37	RXLO4
CA38	TXBFO
CA39	RXLO2
CA40	RXLO3
CA41	IF1
CA42	IFOUT
CA43	IF4
CA44	TXVFO
CA45	IF2
CA46	IF3

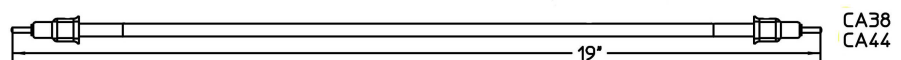
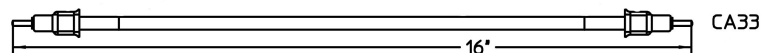
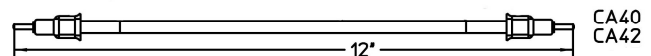
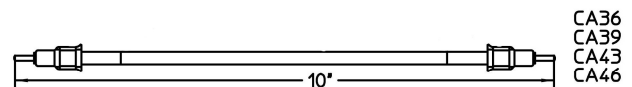
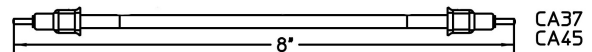
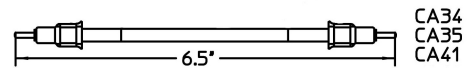



STEP-BY-STEP ASSEMBLY: Chassis, DC Power, PC

Refer to Pictorial 1 for the following steps.

- () Place the chassis bottom on a hard surface. Push the 6" plastic board guide into the holes in the center transmitter compartment until the guide is firmly seated.
- () If the fans in your kit have connectors attached, skip this step. Locate a CA15 2-pin cable with MTA connectors. Cut one end to a length of 6". Strip the leads to 1/4" and tin them. Cut the wires on one fan 3" from the body of the fan. Strip the leads to 1/4" and tin them. Place 1/2" of heatshrink tubing over the ends. Solder the red wire from CA15 to the red wire of the fan. Solder the black wire of CA15 to the other wire on the fan (some fans use black wires, some blue). Place the heatshrink tubing over the solder joints and apply heat until the tubing shrinks.
- () Examine the revision code on your DCD/Tuner board (see the PC Board kit box). If your DCD/Tuner Board is rev B1 or greater, skip this step. Clip the wires at the end of the other fan cable, removing the connector. Using the directions in the previous step, using another CA15 cable cut so that the total length of the fan cable from the fan body to the MTA connector is 18".
- () Position the front bracket with the top and bottom folded sides facing you and the fan mounting holes toward your left. Attach the fans to the back side of this bracket with four 6-32 x 1/2" screws, a metal finger guard and four 6-32 KEPS nuts. (Hint: use a 5/16" socket wrench on 6-32 KEPS nuts.) Make sure the airflow arrow on the fans points toward the back, with the power cable on the bottom. Holding the front bracket as described, the KEPS nuts should be visible to you and the screw heads should touch the fans. See Photo 1.
- () Attach the front bracket to the chassis bottom using one 6-32 x 1/4" screw in the middle hole.
- () Attach the two large rubber feet to the bottom of the chassis and into the outer two holes on the front bracket using two 6-32 x 1" screws. See Photo 2.
- () Attach the two small rubber

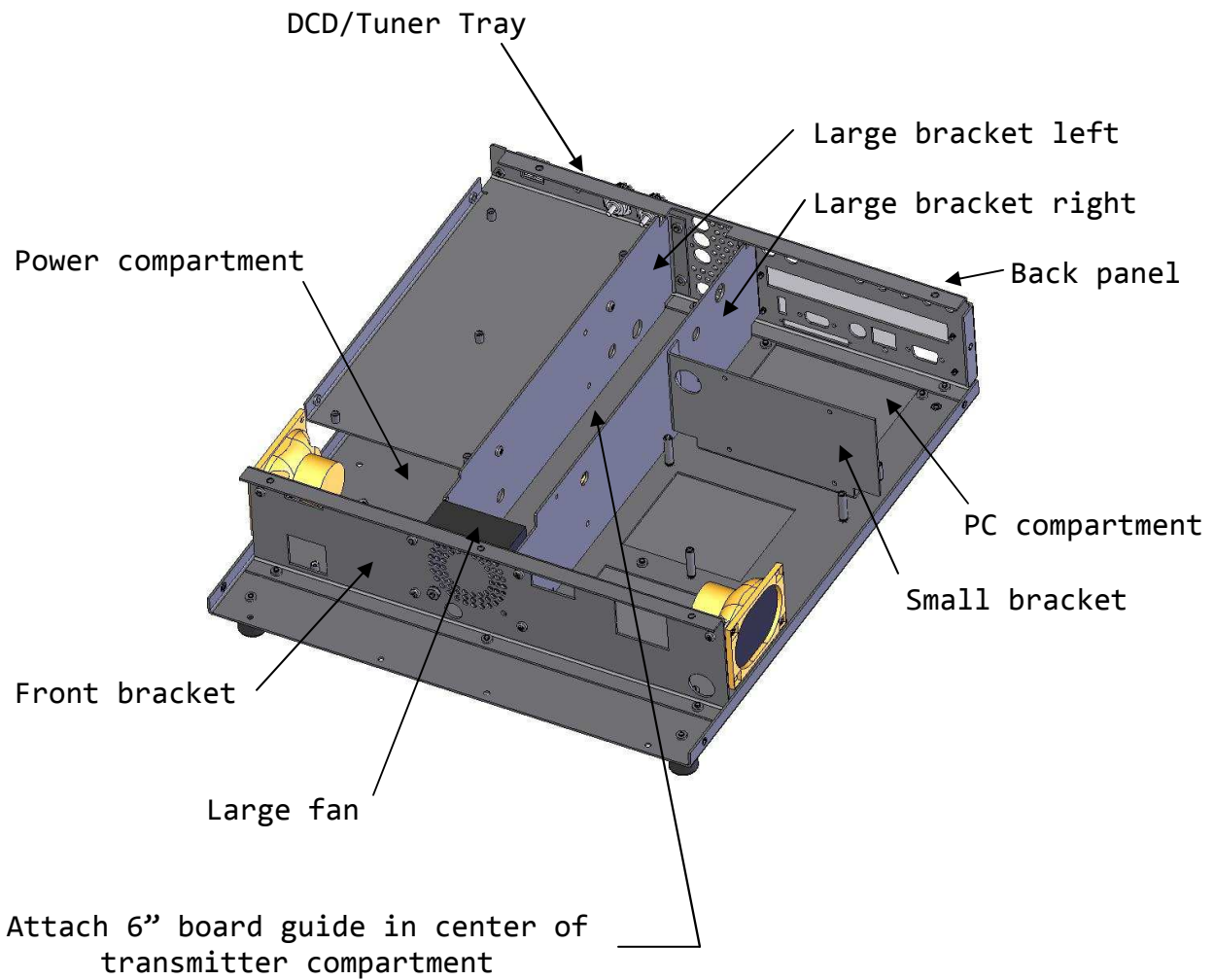

Pictorial 1

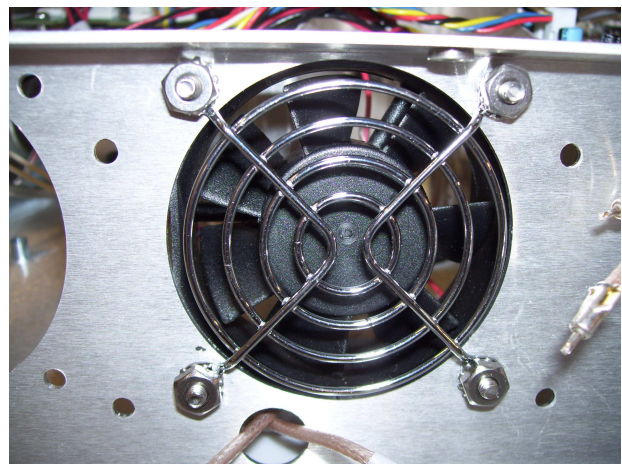
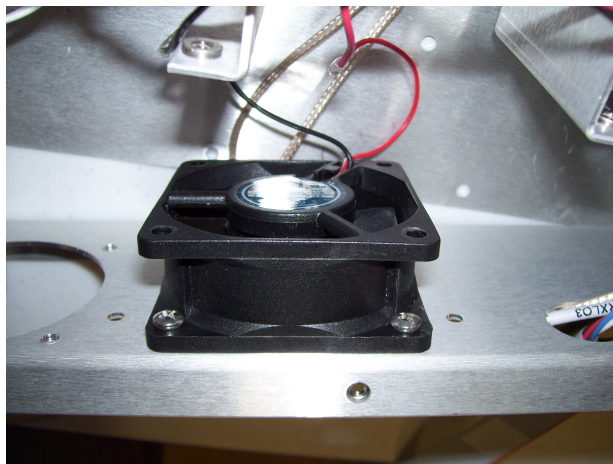

Photo 1. Fan mounting



feet to the two holes on the back, directly opposite the front feet, using two 6-32 x 1/4" screws. See Photo 2.

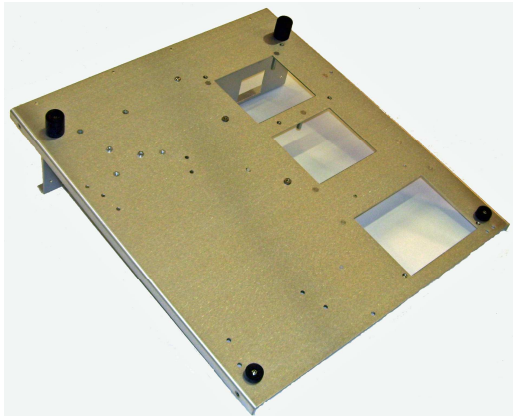

Photo 2. Feet mounting

- () Position the two large brackets on each side of the fan such that the long side is perpendicular to the front of the radio and the back folds face each other. Attach these brackets to the front bracket using four 6-32 x 1/4" screws.
- () Attach the small bracket to the right large bracket using two 6-32 x 1/4" screws. The folded sides on the small bracket face toward the back. Do not attach screws to the bottom at this time.
- () Locate a 2-pin MTA cable (CA15). Cut it so that one length is 10". Cut the other piece so that it is 4" long. Strip all exposed ends of both cables to a length of 1/4". Tin all 4 ends. Twist the wires about 2 turns per inch if they are not already twisted. Place a 1/2" length of 1/8" heatshrink tubing over each wire. Using the 10" length of cable, solder the red wire to + and the black wire to - on one loudspeaker. Position the heatshrink over the terminals and heat them with a heatgun or soldering iron.
- () Using the 4" length of 2-wire cable you just prepared, solder the red wire to + and the black wire to - on the other loudspeaker. Position the heatshrink over the terminals and heat them with a heatgun or soldering iron.
- () Refer to Detail 1. Attach the speaker with the 10" cable to the left side (as viewed from the front of the unit) of the chassis bottom using one angle bracket, one 6-32 x 1/2" hex male/female spacer, one 6-32 KEPS nut and two 6-32 x 1/4" screws. Position the terminals such that they point towards the front of the unit.
- () Attach the diagonally opposite mounting hole on the left speaker to the front bracket using one angle bracket, one 6-32 KEPS nut and two 6-32 x 1/4" screws.
- () Repeat the previous two steps for the right speaker, mounting it to the right side of the chassis.

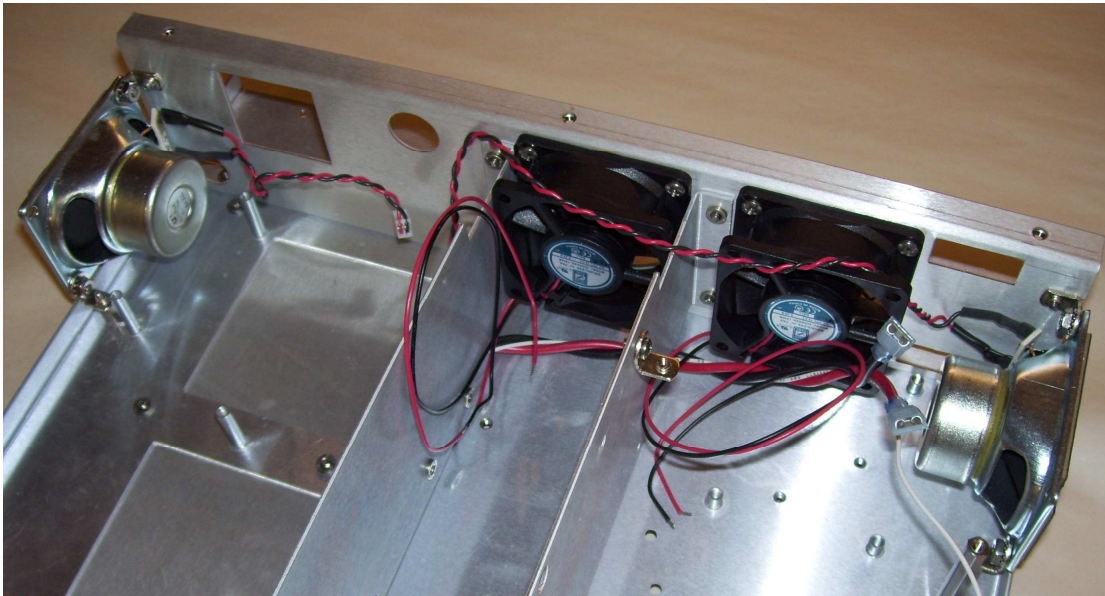
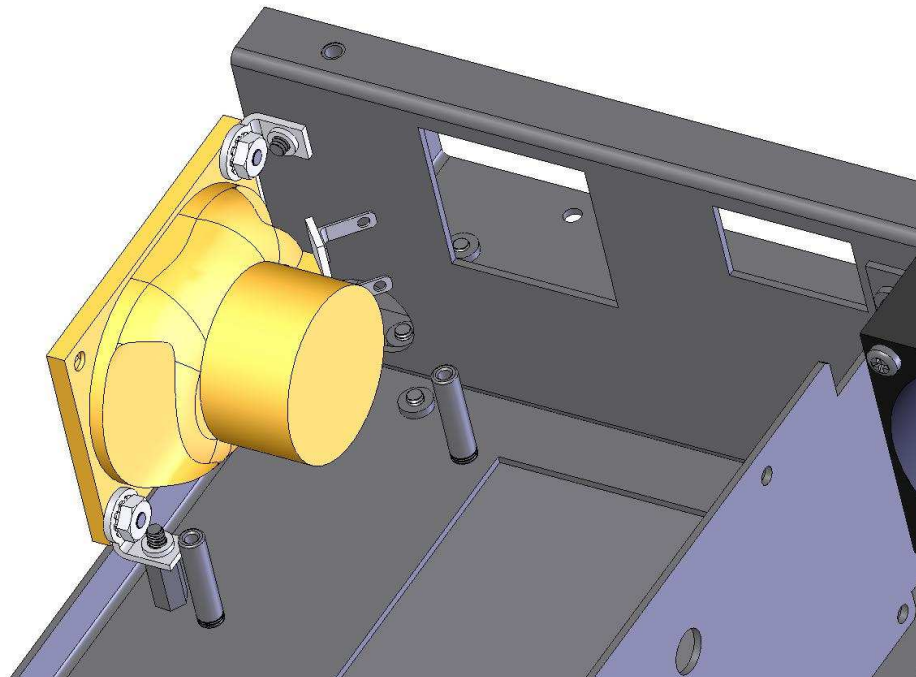

Photo 3. Fans, speakers and PCPS cable routing



Detail 1. Right side speaker mounting



If you have purchased the internal PC (Option 105):

- () Locate CA6, the PC power cable. Set the end with the 2 quick disconnect connectors, white unterminated wire and loose red and black wires into the power compartment. Dress the cable under the left bracket, under the fans under the right bracket, then along the right bracket, under the small bracket and into the PC compartment.
- () Unpack the PC. Be sure to observe handling precautions to avoid static discharge which could damage this board. Remove the 2 jackscrews on each of the DB connectors (VGA and RS-232C) and discard them.
- () Attach CA32 to the PC as shown in Pictorial 2.

right of the front bracket and leave the 6-pin IDC connector in the front controller compartment.

- () Pass the other end of CA12 under the notch in the right side of the small bracket and connect the 2mm rectangular connector to CN8 on the PC (if installed) or to J1 on the small RS232 Board that you earlier attached to the back panel. The tab on one side of the connector faces toward the back of the radio.

NOTE: There may be small tabs on the right and left sides of the 2mm connector which cause a slight bowing of the CN8 connector. This is OK. Make sure that the connector is centered in the CN8 housing.

- () **If you did not install the PC, build the RS232 Board (see Appendix B). Remove the two jackscrews from the 9-pin connector and insert the connector into the hole on the back panel labeled "RS-232C". Secure it using two 4-40 x 3/16" x 5/16" jackscrews (included with Chassis HW).**
- () Locate the 24" 6-pin IDC to rectangular connector cable labeled CONT-PCRS232 (CA12). Pass the IDC end from the receiver compartment through the round hole at the bottom



This page left intentionally mostly blank, but we promise to put something here one day.



- () Make sure that jumpers J3/J4/J5 on the PC are set so that J3's jumper is on, and J4 and J5's jumpers are off.

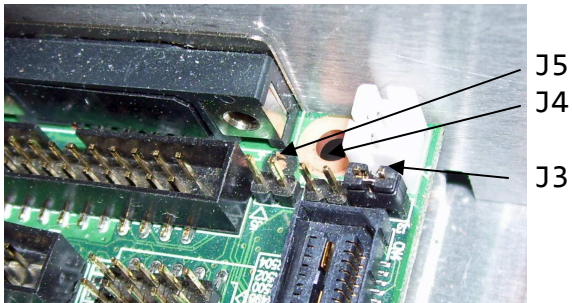

If you have purchased the MIO-6254 board with the PC:

- () Remove jumper J7 in the corner of the PC as shown in Pictorial 2. Leave the jumper in place on J1.
- () Unpack the MIO-6254 box. Remove the 4-40 x 3/4" brass spacers and 4-40 nuts from the bag and attach them to four locations on the PC as shown in Pictorial 3. Tighten the nuts securely on the bottom of the PC except where noted.
- () Carefully push the MIO board onto the PC, making sure to align the row of connectors and mounting holes to that of the PC. Affix it to the PC with the 5 screws that are provided in the bag that is included with the MIO board.

If you purchased the PC:

- () Attach the 12-pin power cable to the PC power connector.
- () Align the board(s) so that the row of I/O connectors is toward the back.
- () Place the PC assembly over the two standoffs that are located in front of the large opening in the bottom chassis. If you do not have the MIO board, secure the PC in the standoffs with two 4-40 x 1/4" screws. If you do have the MIO board attached, loosen the right front corner screw, tighten the spacer in-between the two boards into the chassis-mounted standoff and then re-tighten the screw on the top. The PC assembly is held in place weakly until it is mounted to the back panel in a later step, so do not apply excessive force to it.
- () Align the PC's connectors to the holes in the back panel as you attach the back panel to the chassis.
- () Affix two brass jackscrews to each of the two DB connectors to fasten the PC securely to the back panel.
- () Insert the CF card into the CF tray with the serial number sticker facing up, and insert the tray into the PC from the back panel. Affix

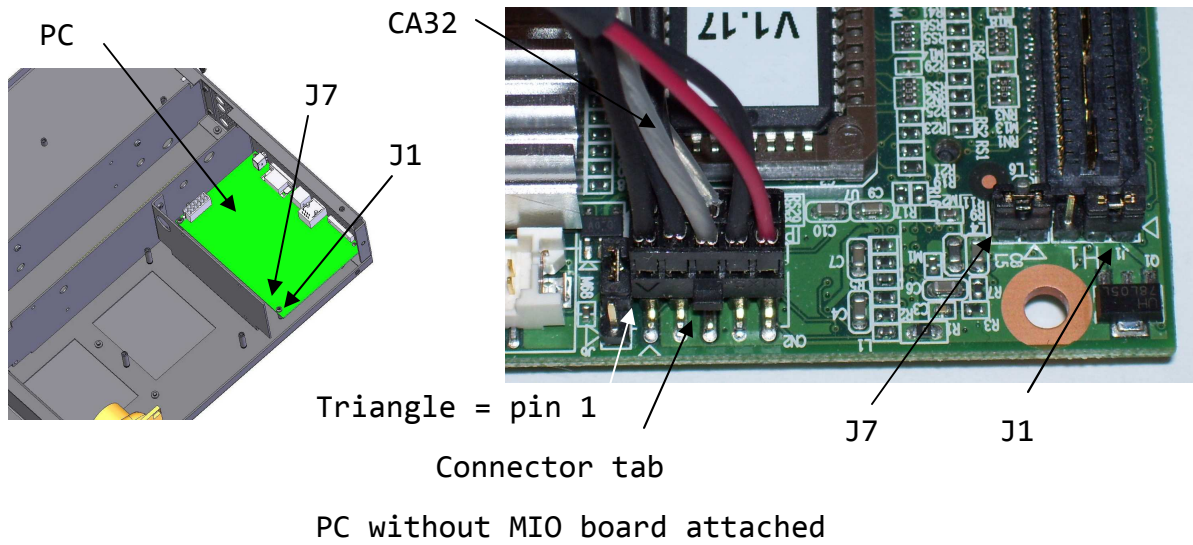

Attach 1 screw to PC/MIO here

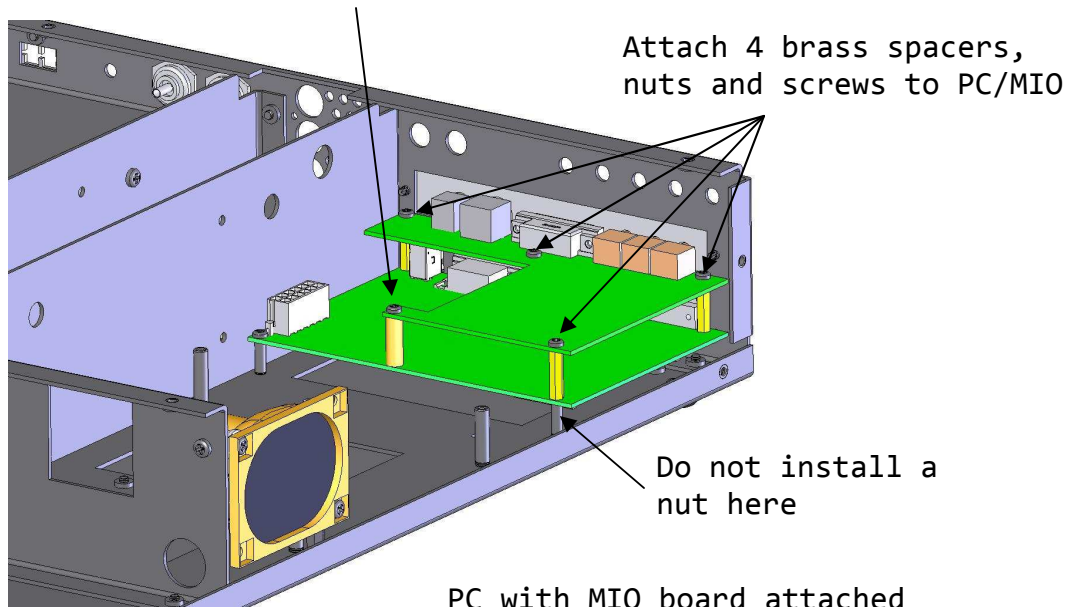

PC with MIO board attached
(small bracket removed for clarity)

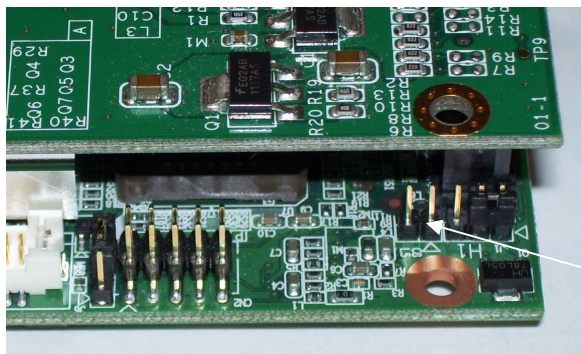

Remove J7 when adding MIO board
and do not install CA32

Pictorial 2



the CF tray to the back panel using two #1 x 1/4" self-tapping screws.

- () If you did NOT install the MIO card, break the PC/MIO cover apart at the breakaway tabs and fasten the smaller piece to the back panel using two #6 x 1/4" self-tapping screws.
- () If you *did* install the MIO board, fasten the MIO-6254

cover (with holes and silk-screening) to the back panel using two #6 x 1/4" self-tapping screws.

- () Fasten the PC/MIO cover bracket to the back panel using four #6 x 1/4" self-tapping screws.
- () Install the PC power supply and optional UPS board (Appendix A).

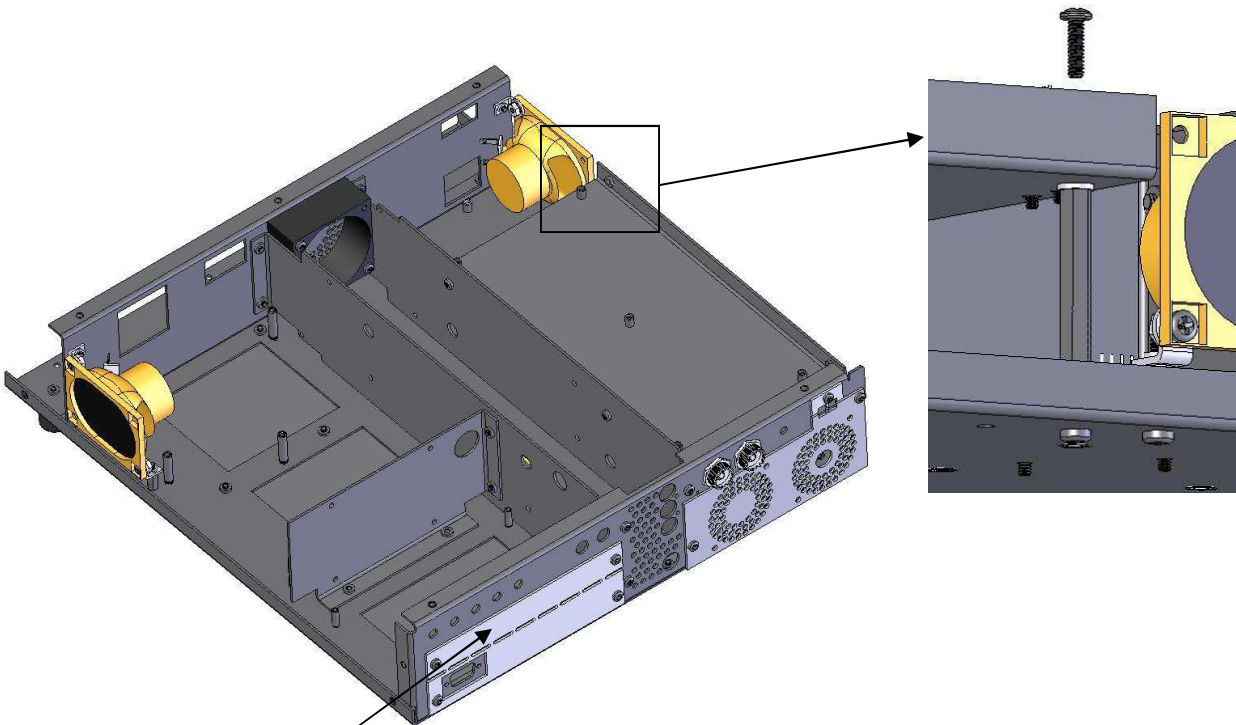

PC/MIO cover. If you have the PC but not the MIO, snap the bottom half of this bracket off at the breakaway tabs.

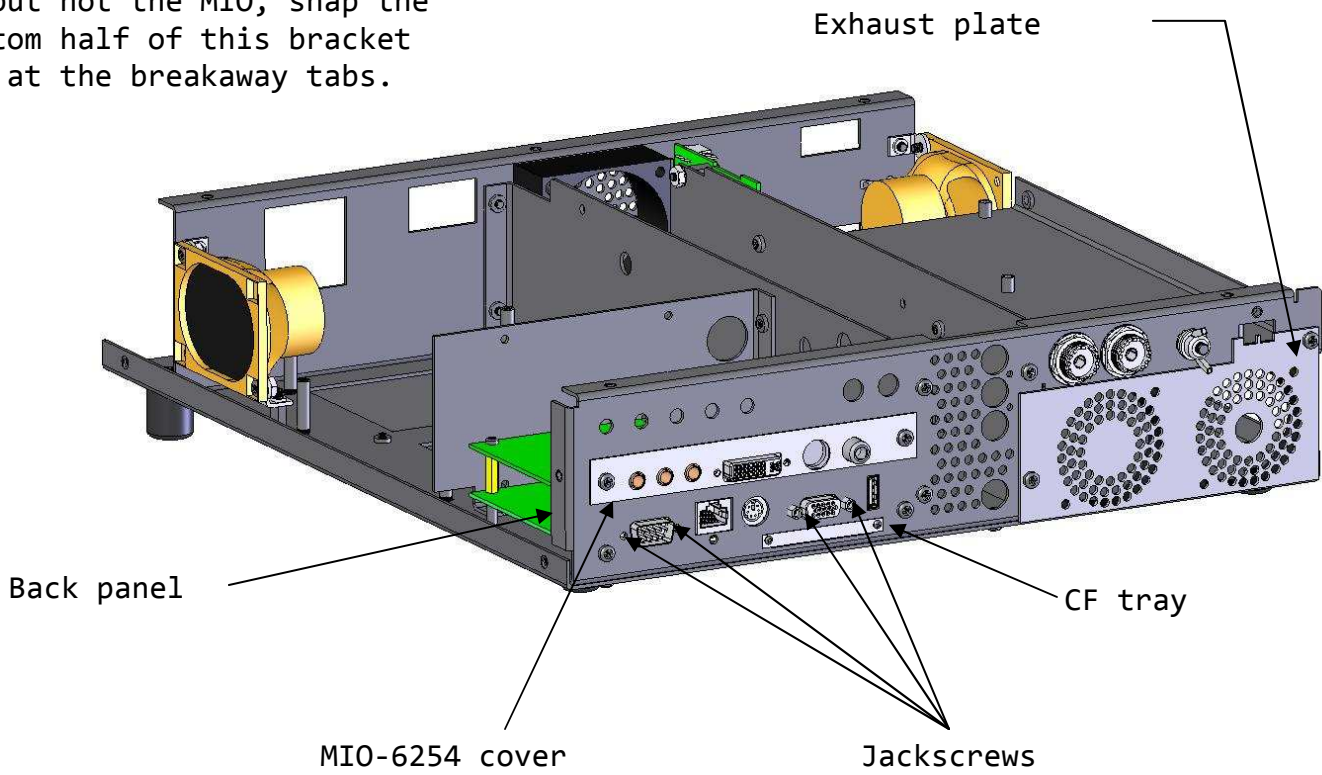

Pictorial 3



Refer to Pictorial 3 for the following steps.

- () Attach the back panel to the back of the chassis bottom using two 6-32 x 1/4" screws on the bottom, two more on the right bracket, and one on the top of the two left bracket holes.
- () Insert two SO-239 connectors from the inside of the DCD/Tuner tray into the large "D"-shaped holes. The lock-washer and nut go on the *outside* of the panel (the side with lettering). Tighten the nuts, being careful not to mar the sheet metal.
- () Attach the ground lug to the hole next to the SO-239 connectors: Place a #10 solder lug on the 10-32 screw and then insert it into the tray from inside. Position the solder lug so that it faces the SO-239 connectors. Secure it tightly with a 10-32 KEPS nut on the outside. (Hint: Use a 3/8" socket wrench.) Place two #10 washers over the screw and then fasten the #10 wingnut finger-tight.
- () Build the DC distribution section of the DCD/Tuner Board. See Appendix C1.
- () If you have purchased the transmitter, build the SWR meter section of the DCD/Tuner board. Parts are provided in the transmitter kit. See Appendix C2.
- () If you have purchased the Tuner option, build the Tuner section of the DCD/Tuner Board. Parts are provided in the tuner kit. See Appendix C3.
- () Affix two TO-220 Thermalsil insulators to the DCD/Tuner tray on the two holes near the front edge. Be sure to uncover the hole in the insulators and line the holes on the chassis up with the openings in the insulators. See Detail 2.
- () Attach the DCD/Tuner board to the tray using four 6-32 x 1/4" screws in three corners and the center. Do not put a screw in the front left corner (near J8).
- () Apply heat to the pin you soldered earlier on U8 and push it down flush with the chassis. Move it back and forth until the hole in the tab lines up precisely with the hole in the chassis. Be careful not to let the soldering iron touch the connectors that are nearby.
- () Insert a #4 shoulder washer in the tab hole, then insert a 4-40 x 1/4" screw through the washer and tab.



- () Repeat the previous two steps for transistor Q1.
- () Using an ohmmeter, verify that the resistance from each tab (U8, Q1) to ground is greater than 750 ohms. If you read a short to ground, remove the screws, reposition the parts and try again.
- () Solder all 3 pins of Q1 and U8. Clip the leads, making sure that clippings do not fly into the chassis. Be careful not to let the soldering iron touch the plastic connectors that are nearby.
- () Solder one pin of a gas discharge tube and a 1.5" length of bare wire to each S0-239 antenna connector's center terminal. Connect the other end of each tube to the #10 solder lug as shown below. Dress the parts neatly along the chassis and be careful they do not short to each other or to the chassis. Solder the other end of the bare wires into the pads labeled ANTA and ANTB. Refer to the lettering on the back of the tray for reference.
- () Attach the front left corner of the DCD/Tuner tray to the chassis bottom as shown in the inset drawing in Pictorial 3, using a 6-32 x 2" hex female/female spacer, a #6 x .05" Nylon spacer, a 6-32 x 1/2" screw on top and a 6-32 x 1/4" screw on the bottom.
- () Attach the DCD/Tuner Tray to the left large bracket using two 6-32 x 1/4" screws.
- () Attach the Anderson Powerpole clamp to the back panel using one 6-32 x 1/4" screw. Insert the small tab on the clamp into the opening between the red and black connectors.

Note: The DCD/Tuner tray is designed to be rotated up to a vertical position for troubleshooting of the 100W amplifier. A small right angle bracket is included to hold it in place when vertical. Attach this angle bracket to the one remaining threaded captive nut on the large left bracket using a 6-32 x 1/4" screw.



Gas discharge tube mounting

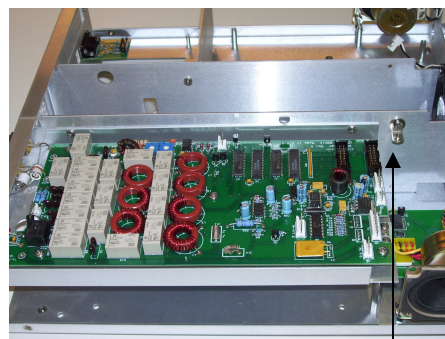

Spare angle bracket mounting



- () Attach the plastic finger guards and metal EMI shields to the outside of the Exhaust Plate using four 6-32 x 1/2" screws and four 6-32 KEPS nuts for each guard. When instructed by the manual, insert the hole plug or fuseholder into the bracket too. When complete, the plate should look like this:

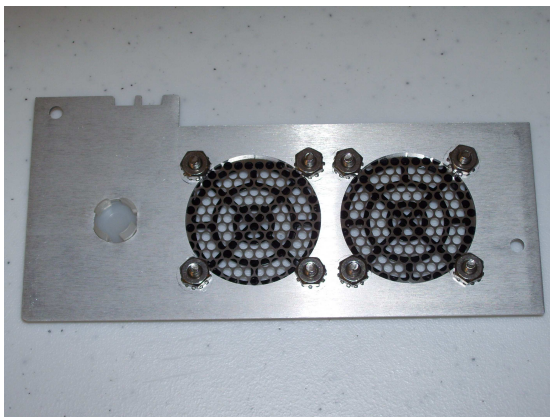

Exhaust plate assembly

If you purchased the 100W PA:

- () Attach a fuseholder (provided with the amplifier kit) to the Fan mounting plate using the provided plastic nut. The rubber washer goes on the outside of the back panel. Tighten it securely.
- () Insert a 25A 3AG fuse into the fuseholder and attach the cap.

Note: If you did not purchase the 100W PA, you can place a battery inside and bring its power cable out the fuse hole. A 1/2" hole plug is provided to cover this hole if you do not plan to use a battery.

- () Attach the Exhaust plate to the back panel using two 6-32 x 1/4" screws. You will need to insert the small tab at the top between the red and black power connectors.





STEP-BY-STEP ASSEMBLY - Initial Tests

- () Locate CA1, the on/off switch with attached cable. Attach the 5-pin connector to J4 on the DCD/Tuner board. Let the other end hang loose, but be careful not to short it to the chassis. (If this cable is not available, short pins 4 and 5 together on J4. These are the two pins closest to the orange Resettable fuse.
- () Run the left fan cable along the left side of the DCD tray and push it onto J5.
- () Locate the pre-assembled Anderson Powerpole cable in the Cable bag. Attach it to the connectors on the back panel and connect the other end to a DC power supply that is capable of delivering 4A at 11-15VDC (12-15VDC if the PC is installed).
- () Apply 12VDC power to the rig. Push the on/off switch. The green LED inside the on/off switch should light and the left fan should run at a low speed with air moving from front to back. Remove power immediately if you smell smoke or see anything wrong.
- () Disconnect the fan from J5 and connect it to J6. The fan should run faster. You can use either J5 or J6 to power the fan. If you do not mind the higher noise level when the fan is connected to J6, leave it there to provide better airflow. If the noise is objectionable to you, use J5.
- () Using a voltmeter, verify that you can measure the applied voltage between the pad marked "To P.A. V+" near the back of the DCD/Tuner board and chassis ground.
- () Using a voltmeter, measure the voltages on J10 (Rx) of the DCD/Tuner board. They should agree with the voltages in Table 1. If any voltages are incorrect, refer to the troubleshooting guide in the Service Manual.
- () Slowly lower the input voltage. As it reaches about 11.5V, the on/off switch should turn red. Below about 9.7V it should go off. Now slowly raise the voltage. Power should come back on once the voltage reaches about 10.8V and the light should turn green once it reaches 11.9V. If this does not happen, refer to the troubleshooting guide in the Service Manual.
- () Push the on/off switch to the off position and verify that the power LED goes off.



Measurement point	Voltage
J10 pin 1	5.0V +/- .15V
J10 pin 2	-9.5V +/- .5V
J10 pins 3 and 5	0.0V +/- .05V (ground)
J10 pin 4	Applied voltage (11-15V)
Anode (unbanded side) of D7	0.25 * applied voltage
Cathode (banded side) of D9 and D5	2.7V
Junction of R24 and R25	0.17 * applied voltage

Table 1. DC Voltages on DCD/Tuner board

- () If you have installed the PC option, connect a monitor, keyboard and mouse to the back of the unit. Apply power and push the on/off switch. You should hear the PC beep and begin its boot procedure. If you want to experiment with the PC for a while, feel free! You've earned some relaxation time. If all is well, push the power switch to off and remove the DC input. Otherwise refer to the troubleshooting guide in the Service Manual.



STEP-BY-STEP ASSEMBLY: Front Panel Integration Models without controls

If you have purchased a Sienna *with* front panel controls, (SF-100 models), go to page 38.

If you are upgrading an existing Sienna by adding a full front panel:

- () Remove power from the connectors at the back of the unit.
- () Remove the top cover.
- () Remove the 4 screws along the bottom of the front panel that hold the front panel to the chassis.
- () Remove all cables from the controller board.
- () Disconnect the on/off switch

from the DCD/Tuner board and push the connector through the hole in the front bracket.

- () Remove the front panel assembly from the unit.
- () Carefully remove the controller board from the existing front panel. Observe static control precautions while handling this board. The controller is attached with six 6-32 x 1/4" screws.
- () Discard the old front panel.

Go to page 38.

Refer to Pictorial 4 for the following steps. (See Parts List in Appendix D1).

- () Remove the controller board carefully from its anti-static bag and observe static control precautions while handling this board. Attach the controller board to the front panel using six 6-32 x 1/4" screws.

- () Clean any oil residue off the front panel sheet metal with a tissue or clean, dry towel.

- () Remove the backing from the front panel Lexan® overlay and attach it to the front panel sheet metal, aligning it carefully before pressing hard to stick it to the sheet metal.

Go to page 43.

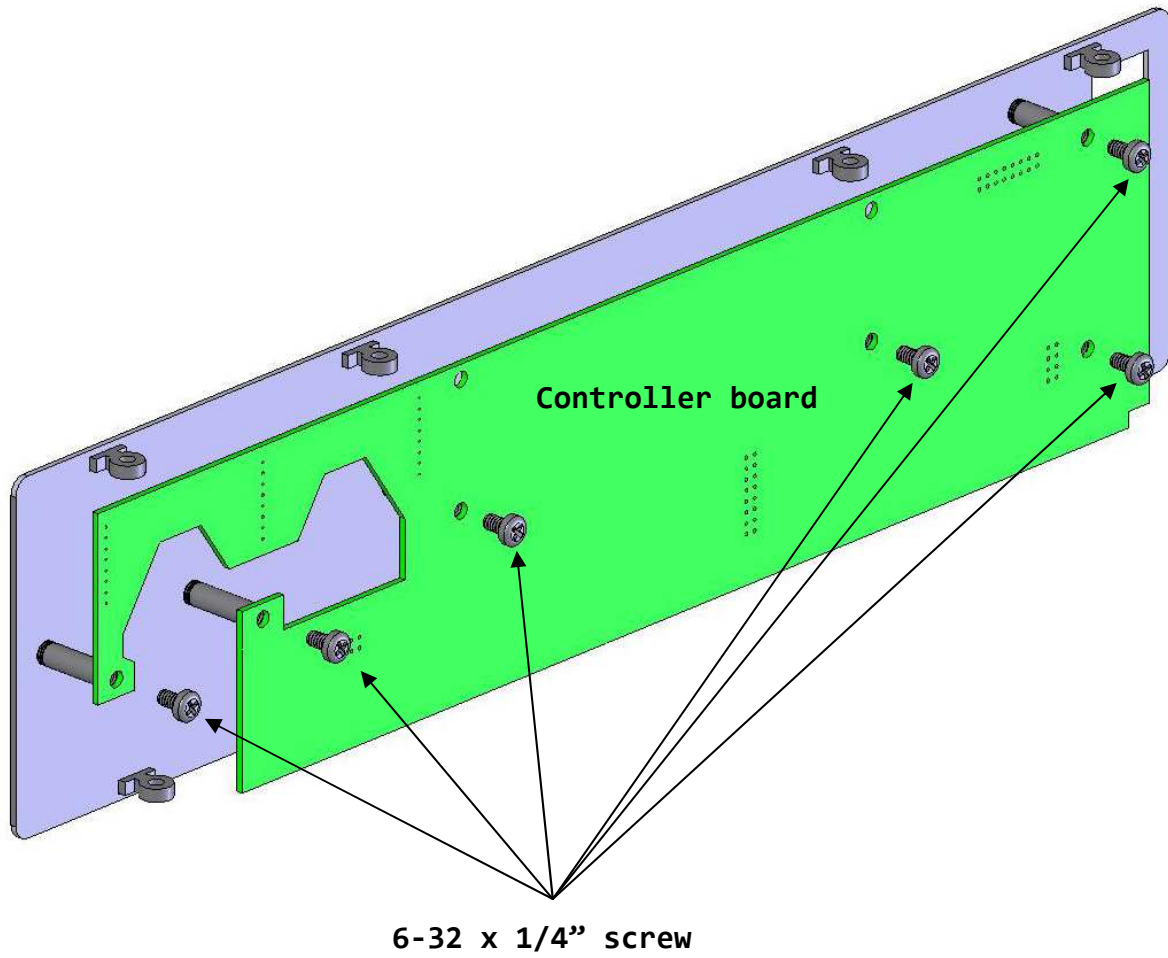

Pictorial 4



STEP-BY-STEP ASSEMBLY - Front Panel Integration Models with controls

- () Build the Front Panel board
(See Appendix D).

Refer to Pictorial 5 for the following steps.

IMPORTANT! It is very easy to mistake the 1/2" spacers for 7/16" spacers. Be sure you use the right ones where called out. Measure them if you need to!

- () Attach two 6-32 x 1/2" hex male/female spacers to the top two VFD mounting holes and secure with 6-32 KEPS nuts.
- () Place the front panel sheet metal upside down on a towel or other smooth surface. Now place the Vacuum Fluorescent Display (VFD) over the large rectangular opening with the glass facing down and connectors to the right. Line up the two bottom mounting holes with the two short captive standoffs on the sheet metal. Insert two 6-32 x 1/2" hex male/female spacers in the bottom two holes, with the threads going into the standoffs on the sheet metal.
- () ***Make certain that the nut and washer on the rotary switch have been removed and saved.***
- () Push the front panel board onto the back of the steel front panel. Attach it with

four 6-32 x 7/16" hex male/female spacers, and six 6-32 x 1/4" screws.

- () Locate the two analog meters. Push the meters into the back of the steel front panel (meter faces visible from the front). Put the S-meter closest to the side of the sheet metal (left side as viewed from the back) and the transmit meter toward the inside (right side as viewed from the back). Handle the front panel sheet metal by the edges to avoid getting oil from your fingers on it.

- () Locate the two Rotary Pulse Generators (RPG). ***Remove the nuts and lockwashers from their shafts and save them for use the next step.***

- () Insert both RPGs into their holes in the center of the sheet metal so that the plastic tabs insert fully into the small rectangular holes. Tighten the RPGs using the hex nuts that you just removed from these parts.

For the following steps, be sure that you are properly grounded and working on a static-free work surface. Static can damage the sensitive control board.

- () Remove the controller board

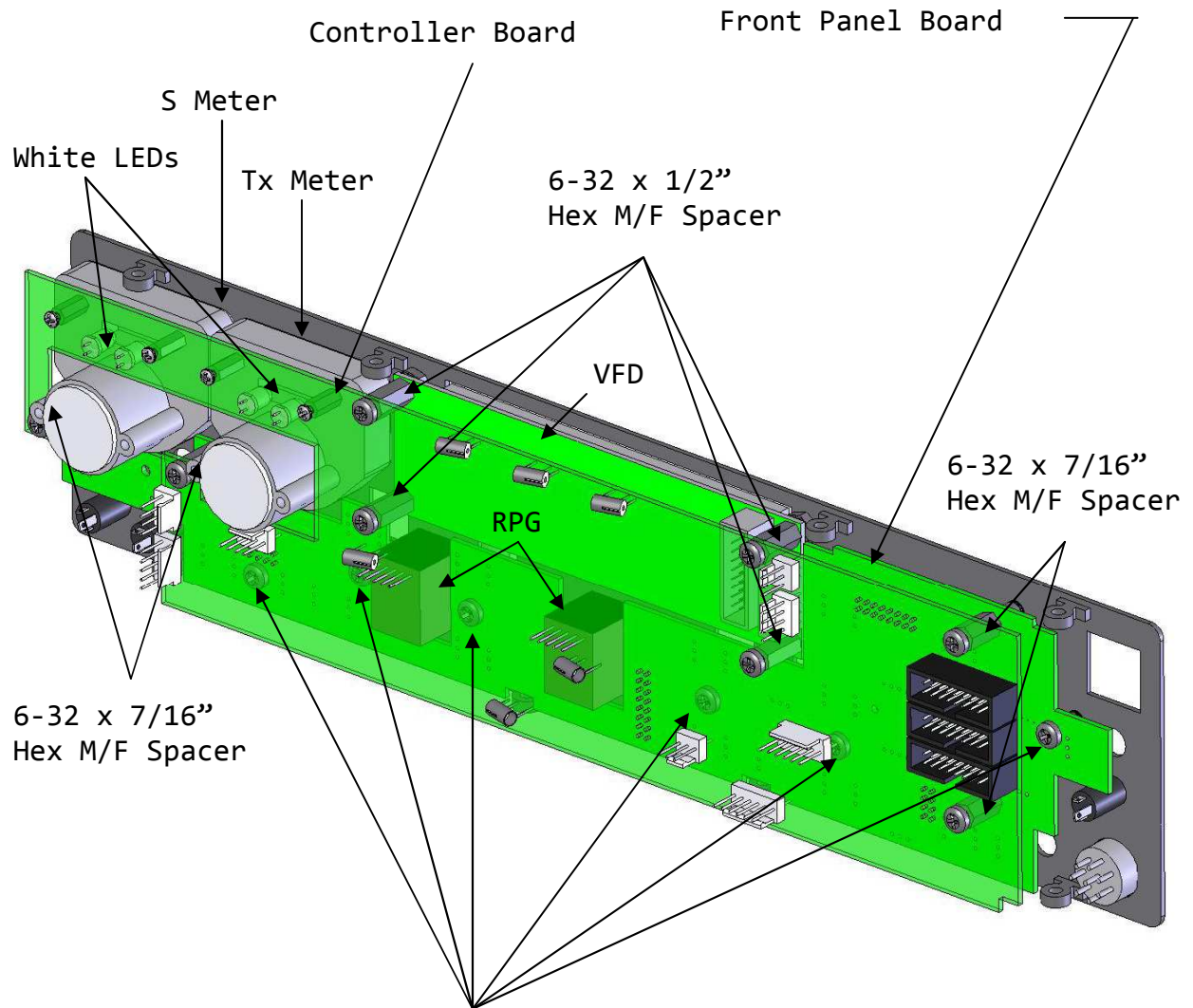

6-32 x 7/16"
Hex M/F Spacer

Six 6-32 x 1/4" screws secure
front panel board to sheet metal

Eight 6-32 x 1/4"
screws secure control-
ler to VFD and front
panel board

Pictorial 5



from its anti-static bag.

- () Solder the four white LEDs *to the back side of the controller board* with the flat side facing up. Clip the excess leads.
- () Attach the controller board to the front panel assembly. A fair amount of pressure is required to align the five connectors (four to the front panel and one to the display) while aligning the 5 pins on each RPG with their holes in the controller board. Push and wiggle the board gently but firmly until all connectors are lined up. The board may flex a little during this process. Once snug, tighten the controller to the front panel and display using eight 6-32 x 1/4" screws.
- () Fasten the meters to the controller board using four 2-56 nuts.
- () Solder all 5 pins of each RPG to the controller board.
- () *Remove the nuts and Lockwashers from the RPGs and save them for later use.*
- () *Make certain that the nut and washer on the rotary switch have been removed and saved.*
- () Clean any oil residue off the front panel sheet metal with

a tissue or clean, dry towel.

- () Remove the backing from the front panel Lexan® overlay and attach it to the front panel sheet metal, aligning it carefully before pressing hard to stick it to the sheet metal. Smooth it carefully to avoid having air bubbles form in it.
- () Attach the RPG nuts and lockwashers to the two RPGs and tighten. Do not over-tighten to avoid dimpling or cracking the overlay.
- () Attach the nut and washer to the rotary switch and tighten the nut.
- () Locate a 2-wire MTA cable assembly (CA15). Cut the cable in half. Strip 3/8" of insulation off the ends and tin them. Slide 1" of heatshrink tubing over each wire. Solder the black wire to the black wire on the S-meter and the red wire to the red wire on the S-meter.
- () Repeat the previous step using the other half of the CA15 cable and solder the ends to the transmit meter.
- () Do not attach knobs at this time in the event you need to disassemble the unit for any reason. They will be attached during final integration.







STEP-BY-STEP ASSEMBLY - Connect Controller Cables

Make sure that no DC power is applied to the DC input connectors on the back panel while you connect internal cables. Do not simply rely on the on/off switch being off, because you could accidentally bump it to the ON position while working on the cables.

If you have purchased the full front panel:

- () Run the free ends of the meter cables through the large rectangular hole on the right of the front bracket and into the Receiver compartment.
- () Remove the knurled nuts from the minijacks on the CONT-FPKEY (CA11) cable. Insert the minijacks into the front panel with the minijack having all three pins attached to wires into the hole marked **Paddles** and the other one into the hole marked **Manual**. Fasten the knurled nuts tightly against the front panel. Do not overtighten to avoid dimpling the polycarbonate overlay. Connect the free end of CA11 to J32 on the controller board.

If you have purchased the transmitter:

- () Insert one end of a 20.5" gray ribbon cable (CONTDATA-TX – CA21) into the top of three 16-pin connectors, J2 (Tx), on the Controller board. Dress the other end through the top rectangular hole in the front bracket. Fold the cable at a right angle close to the DCD/Tuner board. Fold it over 90 degrees downward into the transmitter compartment. Fold it again at right angles such that it runs along the middle of the left bracket toward the back.
- () Locate the 10" stereo minijack to 3-pin IDC connector (RX-HP – CA24). Remove the knurled nut and save it. Pass the minijack through the front panel hole on the far left side with a headphone symbol next to it. Reattach the nut and tighten securely. Pass the IDC end through the round hole on the upper right side of the front bracket.



- () Locate the 8-pin microphone connector to 6-pin IDC and 2-pin stereo cable (CONT-MIC – CA16). Remove the nut and lockwasher. Insert the 6-pin IDC connector and stereo cable through the mic hole in the bottom left of the front panel. Pass the long cable through the lockwasher and then the nut and then do the same for the 6-pin IDC connector. Tighten the nut on the back side of the panel. Attach the 6-pin connector to J20 on the controller board. Pass the shielded cable through the bottom of the two rectangular holes on the left side of the front bracket, then under the large left bracket and into the transmitter compartment. Note that this cable is provided whether you have the transmitter or not. This allows you to use a hand-held mic to increment or decrement the operating frequency using buttons commonly available on most hand mics.
- () Locate the 16" 4-pin IDC cable (CONT-TXVM – CA18). Connect one end to J7 on the controller board. Pass the other end through the round hole under the fan in the front bracket and into the Transmitter compartment. If you did not purchase the transmitter, pass this cable under the left bracket and into the Power compartment. If you have DCD board revision B1 or greater, connect the fan to J8 (labeled "To cont. (no Tx)"). Otherwise leave this connector on the bottom of the chassis.
- () Unplug the 5-pin on/off switch cable from the DCD/Tuner board. Insert this cable assembly through the square opening in the upper left of the front panel assembly, IDC connector first. Finally, push the on/off switch into the hole until it snaps into place. Insert the IDC connector through the rectangular opening in the front bracket and push it onto connector J4 (on/off) on the DCD/Tuner board.
- () Locate the 15" triple stereo minijack to 5-pin IDC cable (CONT-RPKEY – CA13). Pass the 5-pin IDC through the round hole at the bottom right side of the front bracket and connect it to J3 on the controller board. Run the cable along the bottom of the chassis and under the bottom right side of the small bracket. Remove the three knurled nuts and save them. A white wire is connected to all three connectors. In addition to this wire, one connector has a black wire, one

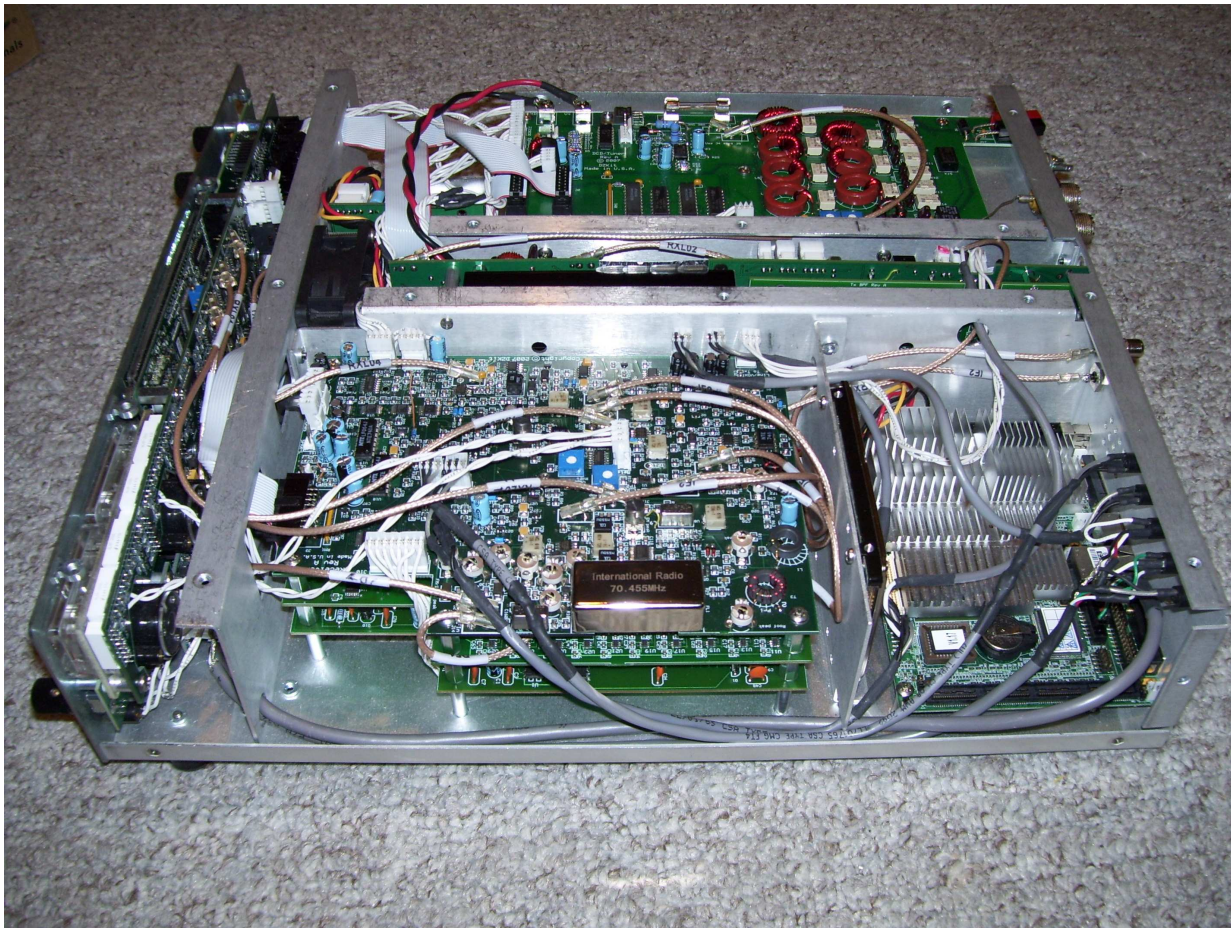

Pictorial 6. Completed unit showing cable dress from controller



a red wire and the other has white and green wires. Insert the one with the black wire into the hole labeled *Keypad*. Insert the one with the red wire into the hole labeled *Manual*. Insert the other into the hole labeled *Paddles*. Tighten the nuts carefully.

- () Locate a 6 1/2" 4-pin IDC cable (CONT-RXVOXST – CA14). Connect one end to J11 (ST/VOX) on the Controller board. Dress the cable through the round opening on the upper right side of the front bracket.

In the next steps you will connect some RF cables. These connectors can be a little tricky to insert into the mating connectors on the PC boards, and they can work loose if inserted and removed more than about 20 times. They have a friction fit and must be aligned perfectly to go in. Once aligned, a gentle but firm push will seat them. Using your fingernails on the "ears" of each cable's connector will help you push them in. Be sure that any strands at the end of the center conductor of the cables are either clipped or lined up with the centerline to avoid difficulty getting the center pin into the mating hole. Once you see how to get the first one in properly, the rest will be easier.

- () Insert RF cable RXL01 into

J24 (RXL01) on the Controller board. Dress the cable through the large rectangular hole on the right side of the front bracket.

- () Insert RF cable RXL02 into J25 (RXL02) on the Controller board. Dress the cable through the large rectangular hole on the right side of the front bracket.
- () Insert RF cable RXL03 into J26 (RXL03) on the Controller board. Dress the cable through the large rectangular hole on the right side of the front bracket.
- () Insert RF cable RXL04 into J23 (RXL04) on the Controller board. Dress the cable through the round hole on the upper right side of the front bracket.
- () Insert RF cable TXVF0 into J22 (TxVF0) on the controller board. Insert the other end through the round hole in the front bracket and into the transmitter compartment. Put a small piece of heatshrink tubing over the end and heat it, so that the connector does not touch the chassis.
- () Insert RF cable TXBF0 into J27 (TXBF0) on the controller board. Insert the TXBF0 cable through the round hole in the front bracket and into the transmitter compartment. Put



a small piece of heatshrink tubing over the end and heat it, so that the connector does not touch the chassis.

If you have purchased the transmitter:

- () Locate a 3-pin IDC cable (CONT-TUNER – CA17) and connect one end to J21 (Tuner) on the controller board and the other to J3 (SWR) on the DCD/Tuner board.
- () Connect the 6-pin IDC connector on CA12 (RS-232 cable) to J4 (RS232C) on the Controller board.
- () Insert one end of an 8" gray ribbon cable (CONTDATA-TUNER – CA22) into the *bottom* of three 16-pin connectors, J18, on the controller board. Dress the other end through the rectangular hole in the front bracket. Make two right-angle folds in the cable close to the DCD/Tuner board so that the cable enters the DCD/Tuner board lined up with connectors J1 and J2. Insert the end of this cable into J1 on the DCD/Tuner board.
- () Locate a 14.5" gray ribbon cable having one connector on one end and two on the other end (CONTDATA-RX-BPF – CA20). Push the end with one connector into the *middle* of three 16-pin connectors, J15, on the Controller board. Fold the cable at a right angle and dress the cable along the underside of the top fold in the front bracket. Fold the other end at a right angle and position it in front of the large rectangular opening on the right side of the front bracket.
- () Locate a 10" 3-pin IDC cable (DCDIST-CONT – CA2). Connect one end to J1 (Power) on the Controller board. Run the other end through the rectangular hole on the left side of the front bracket and into the DCD compartment. Connect CA2 to J9 on the DCD/Tuner board.
- () Temporarily attach the front panel assembly to the chassis bottom using two 6-32 x 1/4" screws. (Four are used when assembly is complete - these just hold it down while you work on other things.)
- () If you have a full front panel, make sure that jumpers JP1 and JP2 are NOT installed on the controller board. These jumpers are located near the meters. If the jumpers are in place, remove them and reinsert them with only one pin making contact. This is a handy way to keep them with the radio so they won't get lost.



STEP-BY-STEP ASSEMBLY-Front Panel/Controller Tests

Units with full front panels

- () Turn on the radio by applying DC power to the APP connectors on the back panel and pushing the on/off switch.
- () You should again hear the PC boot if it is installed. (If you do not wish to cycle power on the PC while testing other boards, simply remove the 4-pin cable at J8 on the DCD/Tuner board.) The front panel pushbuttons should light up briefly and then go out. The VFD should come up with a default frequency of 14.00000 MHz.
- () Push all buttons one at a time and note the response. The LEDs inside the buttons should light when you push the button. Turn the controls to observe their responses. At this point, since you have not yet installed the receiver or transmitter, many of the front panel controls will not seem to do anything. That's OK. As long as it lights up and some buttons respond, you can be sure that the controller and front panel boards are working.
- () Turn off the power and remove the DC inputs.



STEP-BY-STEP ASSEMBLY-Front Panel/Controller Tests Units without full front panels

- () If you do NOT have a full front panel, make sure that jumpers JP1 and JP2 ARE installed on the controller board.
 - () If using an external PC to control the rig, connect its RS-232 port to the DB9 connector on the back panel.
 - () Turn on the radio by applying DC power to the APP connectors on the back panel and pushing the on/off switch.
 - () You should again hear the PC boot if it is installed.
 - () From either the internal or external PC, start the "Hyperterm" program and set it for 9600 baud, 8 bits, no parity, 1 stop bit, no handshake.
 - () Enter the following commands:
ID; { Response: ID710; }
FA; { Response: FA00014000000; }
- If you want to experiment with other commands to observe the responses, consult the Sienna Operator's Guide.
- () Turn off the power and remove the DC inputs.



STEP-BY-STEP ASSEMBLY-Receiver Integration

Refer to Pictorial 7 for the following steps.

- () Build the IF Filter board (See Appendix E).
- () Locate the 4" 8-pin IDC cable (RX-IFFILT – CA26). Connect one end to the IF Filter board. Leave the other end disconnected for now.
- () Install the IF Filter board on the 6 tall standoffs in the receiver compartment with the filters facing down. Use six 6-32 x 5/8" hex male/female spacers to secure the board. Tighten the spacers securely, but do not overtighten to avoid damage to the PC board.
- () Install any standard and optional filters. See Appendix K for information on how to install them and tell the control firmware they are there.
- () If purchased, connect the Test Board and perform the IF Filter test procedure as described in Appendix L.
- () If present, remove the test board and disconnect all cables from it. Save the test board for further use.
- () Remove IF1 from J18 on the IF Filter Board and insert it into J2.
- () Remove IF2 from J19 on the IF Filter Board and insert it into J3.
- () Build the RXBPF board (See Appendix F).
- () Locate the 2.5" 4-pin IDC cable (RX-BPFDC – CA25). Connect one side to J1 on the RXBPF board with the cable extending upward. Do not twist the leads.
- () Lay the RXBPF board on top of the 5/8" hex male/female spacers. Secure it with six 6-32 x 5/8" hex male/female spacers. Tighten the spacers securely, but do not overtighten to avoid damage to the PC board.
- () Remove the mounting nut and solder lug from a BNC connector and insert the connector from the outside of the back panel at the location marked "RX ANT". Reattach the solder lug and nut and tighten it. Bend its solder lug at a 45 degree angle. (See photo on page 52)
- () Solder a gas discharge tube between the BNC center conductor and the solder lug. Be careful not to short the met-

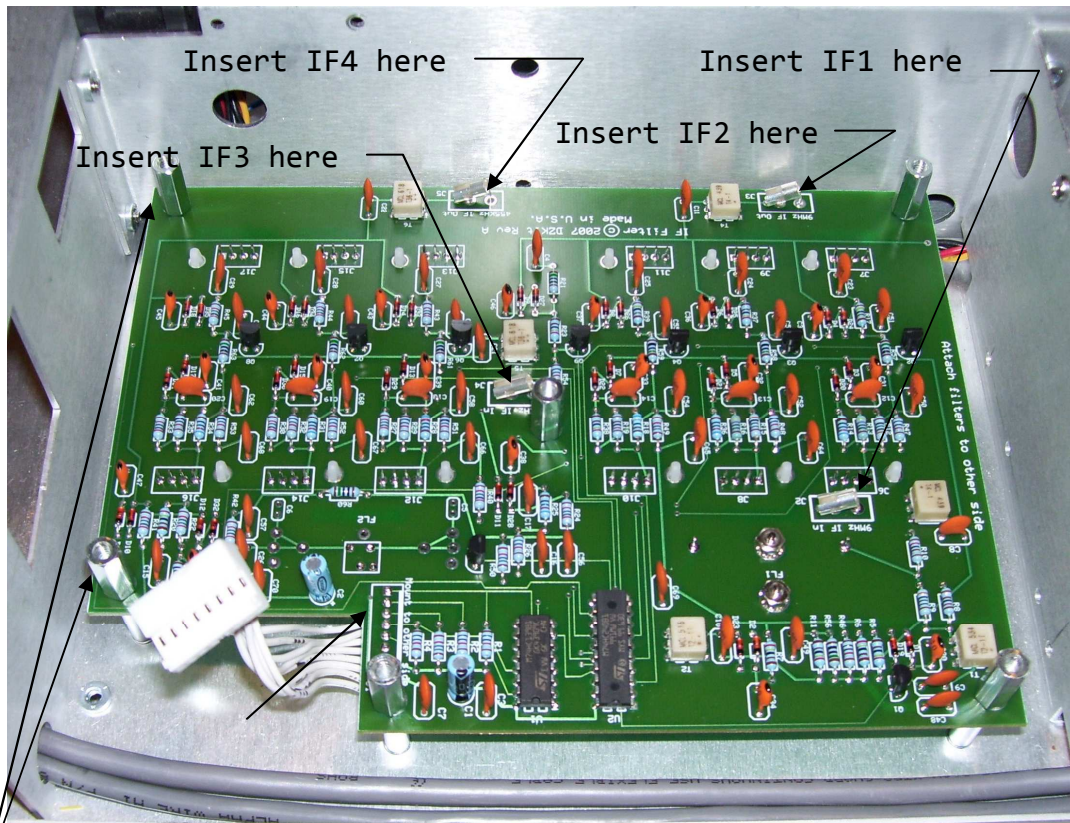

Mount test board here

Pictorial 7. IF Filter Board Mounting



al ends to the chassis.

- () Attach the phono connector to the back panel at the hole marked IF OUT with the solder lug positioned to the right as shown in the photo below. Tighten the nut.
- () Solder the center conductor of the RXANT cable to the center terminal of the BNC connector. Solder the braid to the solder lug. If the braid does not reach easily, add a short piece of hookup wire as shown in the photo.
- () Solder the center conductor of the IFOUT cable to the center terminal of the phono connector. Solder the braid to the solder lug.
- () Pass the other end of the RXANT cable through the large round hole in the small bracket and insert it into the RF connector labeled J3 (Rx Antenna) on the RXBPF board.
- () Leave the other end of the IF OUT cable in the PC compartment for now.
- () Connect the Receiver power cable from J10 (“Rx”) on the DCD Board to J17 (“From DCD (test)”) on the RXBPF Board.
- () Connect the bottom of the two connectors at the end of the gray ribbon cable to J5 on the RXBPF board.
- () If purchased, connect the Test Board and perform the RXBPF test procedure described in Appendix M.
- () Insert RF cable RXBPFMAIN-TX into the RF connector labeled J2 (Main Antenna) on the RXBPF board. Dress the other end of this cable through the large round hole in the small bracket and into the PC compartment, then into the top round holes in large bracket right, large bracket left and into the DCD/Tuner compartment. Connect the end to J11 on the DCD/Tuner board.
- () Locate the 8-pin to 5-pin/3-pin cable (DCDIST-TX – CA4). Connect the 8-pin connector to J7 (Tx) on the DCD/Tuner board. Dress this cable along the top of the large left bracket and into the transmitter compartment.
- () If not already done, remove the IF test board and disconnect all cables going to it. If you do not plan to add the transmitter, install this





board in the transmitter compartment and connect cables as follows:

- () Fan to J7
 - () CONT-TXVM – CA18 to J6
 - () CA4 (5-pin) to J5
 - () CA4 (3-pin) to J4
 - () TXBFO to J8
 - () TXVFO to J11 or J14
 - () Set jumper JP1 to “IF”
 - () Set jumper JP3 to “TX”
- () Attach the Test Board to the chassis using two 6-32 x 1/4” screws.
- () Insert RF cable RF1 in the

connector labeled J4 (To Rcvr) on the RXBPF board.

- () Build the Receiver board (See Appendix G).
- () Remove the 4-pin power connector from J17 on the RXBPF board (“From DCD (test)”) and place it out of the way while installing the Rx board.
- () Carefully place the receiver board on top of the six hex standoffs. Secure it with six 6-32 x 1/4” screws. Make sure no cables are stuck or pinched beneath the board.

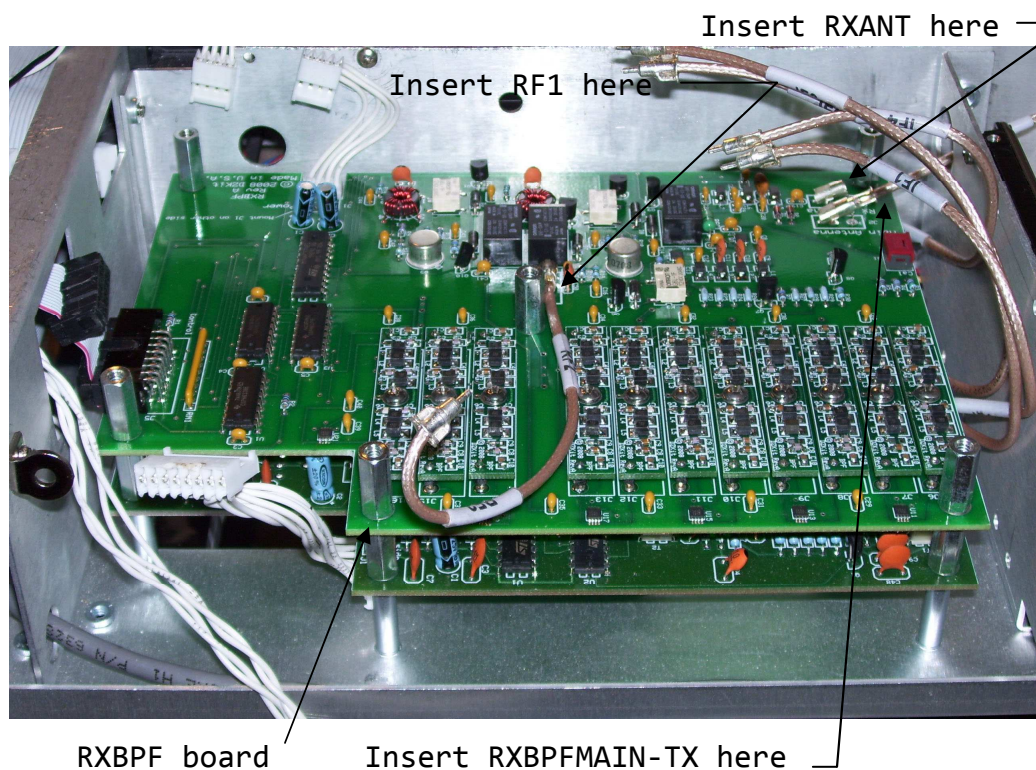



Refer to Pictorial 8 for the following steps.

If you have installed the full front panel:

- () Connect the 2-pin connector coming from the S-meter to J19 (Meter) on the Receiver board.
- () Connect the 2-pin connector coming the Tx Meter to J25 (Tx Mtr) on the Receiver board. This meter is present even if you did not purchase the transmitter.
- () Connect the cable that is wired to the headphones (RX-HP – CA24) to J6 (Phones) on the receiver board.
- () Locate the IDC cable that is connected to J11 (CONT-RXVOXST – CA14) on the Controller board. Connect the other end to J24 (Sidetone/VOX) on the Receiver board.
- () Locate the 2.5" 4-pin IDC cable coming from the RXBPF board (RX-BPFDC – CA25). Connect it to J13 on the Receiver board.
- () Locate the 3" 8-pin IDC cable coming from the IF filter board (RX-IFFILT – CA26). Connect it to J10 on the Receiver board.
- () Locate the 10" 3-pin IDC cable labeled RX-TXLINE (CA29). Attach one end to J23 (Line/VOX) on the receiver board. Run the other end through the large round hole in the small bracket and then through the round hole in the right bracket and into the Transmitter compartment.
- () Locate the 10" stereo mini-jack to 3-pin IDC cable (RX-RPLINEIN – CA30). Remove the knurled nut from the minijack and save it. Connect the IDC end to J21 (Ext In) on the Receiver board. Pass the other end through the large round hole in the small bracket and through the hole in the back panel labeled "Line In". Reattach the nut and tighten securely.
- () Locate the 15" stereo mini-jack to 3-pin IDC cable (RX-RPLINEOUT – CA31). Remove the knurled nut from the minijack and save it. Connect the IDC end to J16 (Ext Out) on the receiver board. Pass the other end around the right side of the receiver stack, under the right side of the small bracket and through the hole in the back panel labeled "Line Out". Reattach the nut and tighten securely.
- () Insert RF cable RF1 into J14 (RF In) on the Receiver

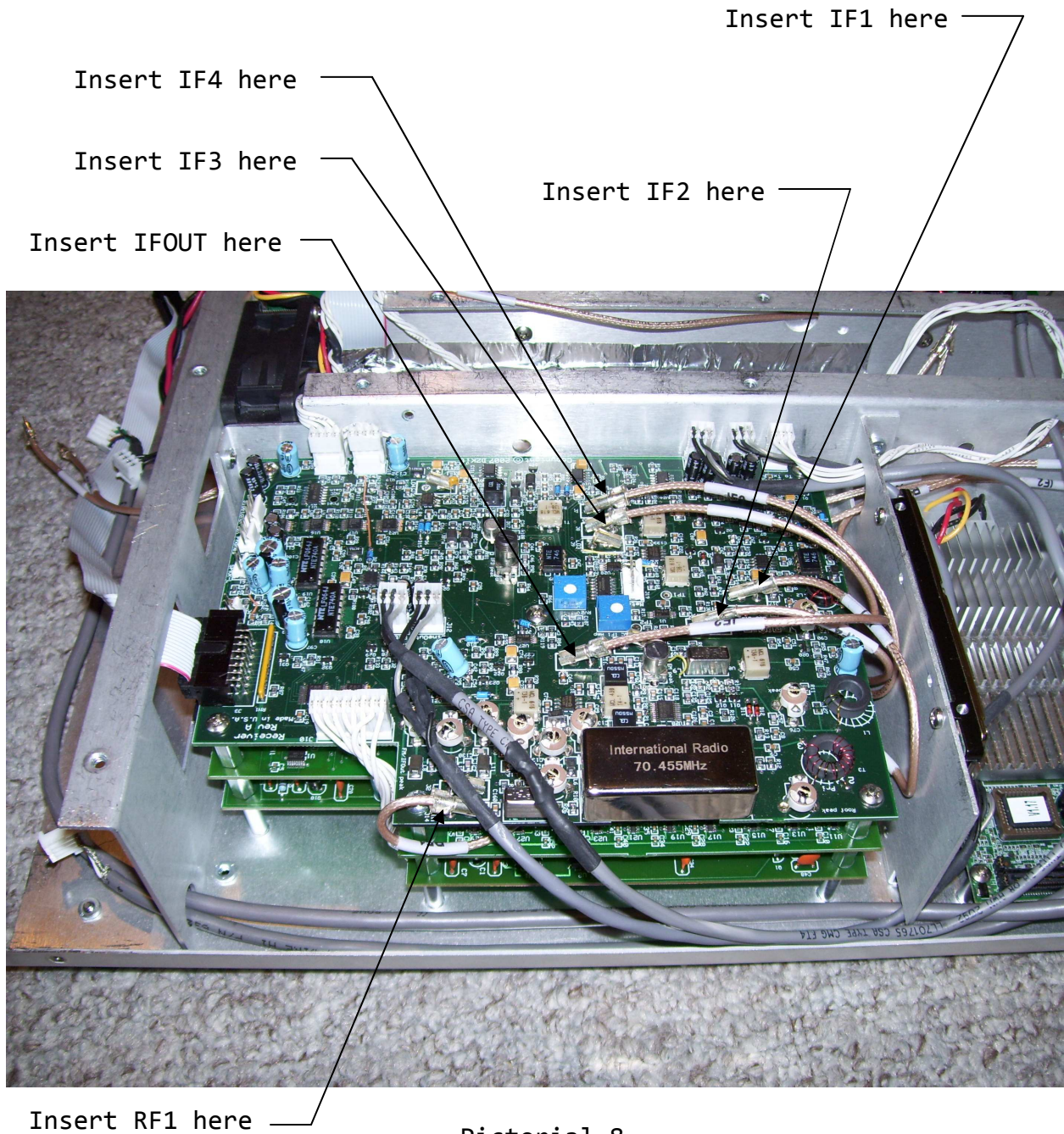

Pictorial 8



board. This cable makes a tight turn as it comes up from the RXBPF board.

- () Insert RF cable IF1 into J17 (IF1-To9M) on the Receiver board.
- () Insert RF cable IF2 into J11 (IF2-From9M) on the Receiver board.
- () Insert RF cable IF3 into J8 (IF2-To455) on the Receiver board.
- () Insert RF cable IF4 into J7 (IF2-From455) on the Receiver board.
- () Insert RF cable RXL01 into J2 (marked L01) on the Receiver board.
- () Insert RF cable RXL02 into J15 (marked L02) on the Receiver board.
- () Insert RF cable RXL03 into J9 (marked L03) on the receiver board.
- () Insert RF cable RXL04 into J1 (marked L04) on the receiver board.
- () Locate the IF OUT cable (CA42) that was left in the PC compartment in an earlier step. Insert the free end into J26 (IFOut) on the receiver board.
- () Connect the top connector on the CONTDATA-RX-BPF ribbon cable (CA20) into J3 on the receiver board.
- () Locate a 10" 4-pin-5-pin IDC cable (DCDIST-RX – CA51). Connect the 5-pin end to J10 (Rx) on the DCD/Tuner board. Dress this cable along the top of the unit, around the fan and into the receiver compartment. It is important that this cable not protrude above the fan so that it does not get pinched when the top cover is installed, so position it in the gaps around the back and sides of the fan. Connect the 4-pin end to J5 (Power) on the Receiver board.
- () Dress the left speaker cable along the top of the chassis, next to the fan, and plug the connector into J22 (SPKR-L) on the Receiver board.
- () Dress the right speaker cable along the top of the Receiver board and plug the connector into J4 on the board.



() If you have installed the PC option and NOT the MIO board, locate the cable assembly that you attached to the PC earlier that has three cables attached to a 2mm rectangular connector (PC-RX/TX – CA32). Pass the cable with the 2-pin MTA connector on the other end through the hole in the right bracket and into the transmitter compartment. Pass the shorter of the two cables with 3-pin IDC connectors through the large round hole in the small bracket and connect it to J20 (Line In) on the receiver board. Connect the longer of the cables to J12 (Line Out) on the receiver board. Dress it along the bottom of the chassis and under the small bracket.

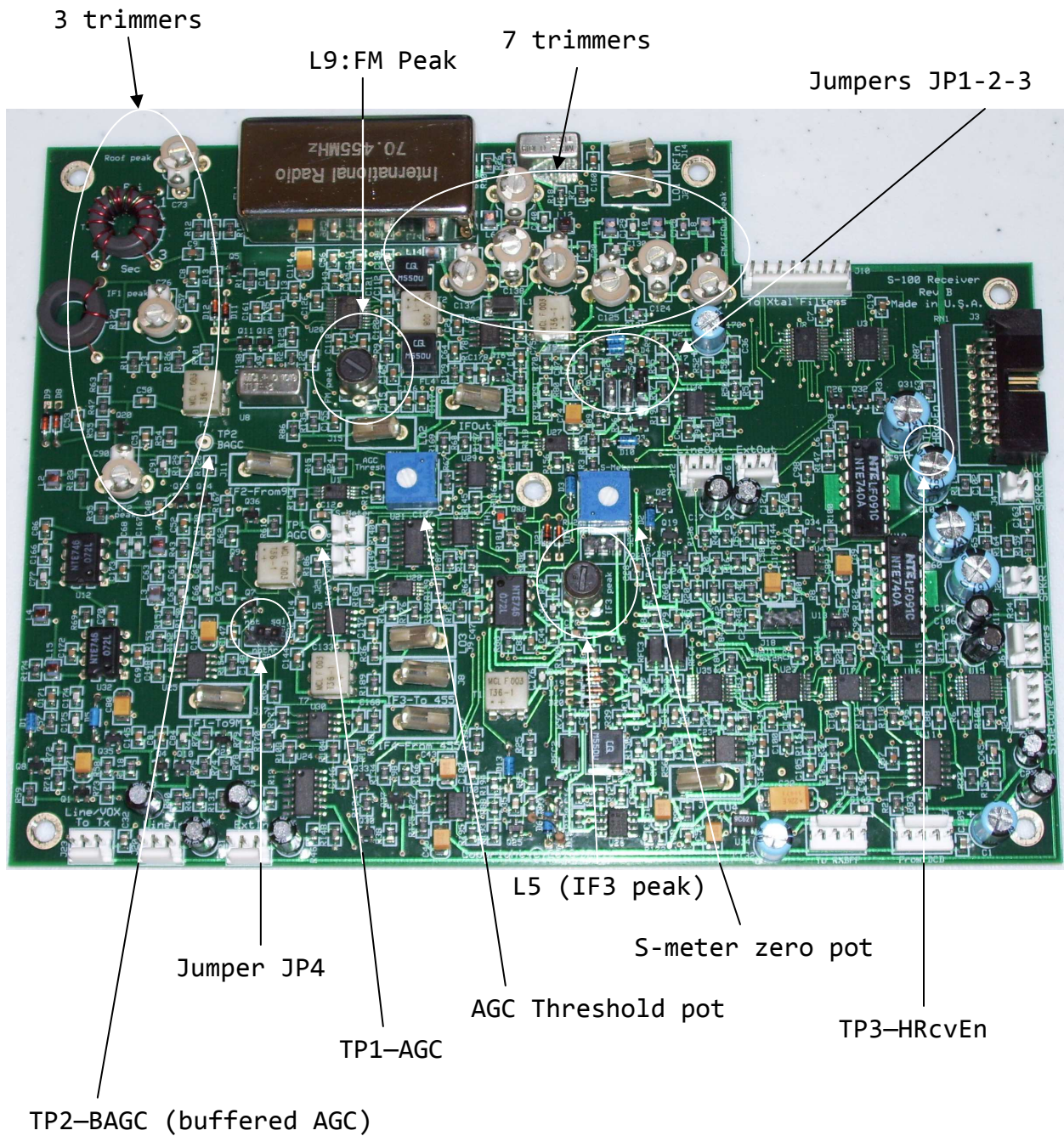

Pictorial 9



STEP-BY-STEP ASSEMBLY - Receiver Alignment/Tests

Using full front panel

If you have a blank front panel, go to page 64

When so instructed, connect a voltmeter to the test points described below (red to the noted test point, black to any point on the chassis).

If you are using an S-100 model (no front panel controls), go to page 64.

The radio should be off before starting these steps.

- () Temporarily disconnect the 5-pin power cable from the DCD/Tuner board (J10) that goes to the 4-pin connector J5 on the Receiver board (DCDIST-RX - CA51).
- () On the 5-pin connector at the end of CA51, measure the resistance between pin 1 and ground. (Use the exposed metal pins on the side of the connector.) It should be >1K ohms. Now measure the resistance between pin 2 and ground. It should read > 400 ohms. Finally, measure the resistance between pin 4 and ground. It should read > 100K ohms. Pin 3 is grounded and should read less than 1 ohm. Pin 5 is not connected and should read open. If you measure incorrect values at any of these points, refer to the troubleshooting section

of the Service Manual.

- () Disconnect any antennas from the antenna jacks on the Back Panel.
- () Reconnect the Receiver power cable to the DCD/Tuner board (J10).
- () Disconnect the TXBFO cable from the Test Board and reconnect it temporarily to J14 ("To P.A.") on the DCD/Tuner board. This connects the 10.7MHz transmitter local oscillator to the antenna input, which is also connected to the RXBPF board's antenna input. (Note: If you are redoing this step after having installed a transmitter, remove the RF cable from the transmitter output to the DCD board.)
- () Flip switch S1 on the RXBPF board to the "Rcv" position.

Note: The following steps adjust the 71MHz low pass filter, the 9MHz bandpass filter and the FM receiver peaking. Since this signal path is also used to create the 455kHz IF Output, you can also peak the signal using an external panadapter connected to the IF Output jack instead of us-



ing the internal IFOut-to-IF4 connection. An RFSpace SDR-IQ receiver is recommended for this, but any spectrum analyzer capable of displaying frequencies around 455kHz can be used. If you choose to do this, ignore the S-meter readings and peak the signal on the panadapter.

- () Set both trimpots on the Receiver Board in their middle position.
- () Turn on the radio by applying DC power to the APP connectors on the back panel and pushing the on/off switch.
- () Measure the voltages on page 63. If any are incorrect, turn off power, remove the receiver board and check carefully for soldering problems.
- () Press PAGE/MODE to allow the mode to be changed. Rotate the small tuning knob to select FM mode. Press PAGE/MODE again to exit. Tune the radio to 10.700 MHz.
- () Rotate the NB Thr/FM Sql knob counterclockwise on the front panel until you can hear audio coming out of the speakers.
- () Press MENU and then rotate the small tuning knob until you see a selection called “FM/IF Test”. Select it with the large tuning knob . (If it is the first item in the menu, rotate the large knob off of the selection and back again). Turn the function on by rotating the small knob until the selection reads “On”.
- () Using a small screwdriver, adjust variable inductor L9 (“FM Peak”) for a maximum reading on the S-meter. Typically, the coil’s slug will be near the bottom (almost fully tightened).
- () Using a small, insulated screwdriver, adjust the 7 trimmer capacitors (in a group to the right of the large roofing filter) so that you see a maximum reading on the S-meter. When properly adjusted, the strong carrier at 10.7MHz should cause a fully quieted signal (no noise) in the speakers.
- () Turn off the FM/IF Test function by rotating the small knob so that the selection reads “Off”.
- () Using either the menu or the PAGE/MODE controls, select CW (USB) mode.
- () Temporarily disconnect the cable end going to the RF in-



- put to the receiver (J14 on the receiver board).
- () Set the RF Gain control to the maximum clockwise position.
 - () Press MENU, then rotate the large tuning knob (the PAGE/MODE LED will go off) until the AGC selection (bottom left side of display) is highlighted. Rotate the small tuning knob until the AGC setting is "AGC-Fast".
 - () Press PAGE/MODE to re-enable menu paging, then rotate the small tuning knob until the menu page appears that has "RFG Cal (F)" as one of the selections. Rotate the large tuning knob to select that item. Touch the red voltmeter lead to TP1 and then turn the small knob to get a voltage reading of 3.81V. A typical value is 22. Write the value here: _____
 - () Use the tuning knobs to select "AGC-Slow".
 - () Select RFG Cal (S). Touch the red voltmeter lead to TP1 and then turn the small knob to get a voltage reading of 3.81V. A typical value is 12. Write the value here: _____
 - () Touch the red voltmeter probe to TP2 and adjust the AGC
- Threshold pot on the receiver board to get a voltage reading of 4.0V.
- () Rotate the RF Gain control to the counterclockwise position. The S-meter should rise to a maximum. Return the control to the clockwise position.
 - () Touch the red voltmeter probe to TP4 (S Cal) [use the junction of R181 and R187 on Rev B boards]. Adjust menu item "S-meter cal" for a reading of 2.1V. A typical value is 147. Write the value here: _____
 - () Flip switch S1 on the RXBPF board to the "Cal" position.
 - () Reconnect the RF cable to J14 on the receiver board.
 - () Re-enable FM/IF Test mode.
 - () Press the Preamp1 and Preamp2 buttons. Both preamp LEDs should now be on.
 - () Peak the S-meter reading by adjusting the main tuning knob.
 - () Using a small, insulated screwdriver, adjust the three trimmer caps toward the back of the board, labeled "Roof peak", "IF1 peak" and "IF2 peak" to achieve a maximum



reading on the S-meter.

- () Adjust variable inductor L5 (IF Peak) for a maximum reading on the S-meter. Typically, the slug will extend out the top of the can about 1/8". It is not a sharp peak but you should notice when it peaks and then starts dipping again.
- () Press MENU. Select the menu that includes the settings for AGC SSB/CW control. Adjust the menu selection until the meter reads S9. Typical value is 150-210. Write the value here: _____

The above steps calibrate the receiver's RF gain so that a signal at the antenna of 50uV (-73dBm) causes the S-meter to read S9 when using two preamps. It will not be as accurate when using zero or one preamp or the attenuator. Typically, you will want both preamps for frequencies above 14MHz.

- () Remove the TXBFO cable from the DCD/Tuner board and plug

it into J8 on the IF Test board (if present) in the transmitter compartment.

- () Set the Rcv/Cal switch to Rcv on the RXBPF board.
- () Exit menu mode. Press the "Page/Mode" button and select AM by rotating the small knob. Also select the receive antenna by highlighting "Rx-T" (transmit antenna A or B) and changing it to "Rx-R" (Receive Antenna). Press "Page/Mode" again to exit this mode. Connect an antenna to the back panel Rx Antenna input. Tune in an AM station in the AM broadcast band. Re-enter menu mode and select the AGC AM setting. Adjust the value until the station is at a comfortable listening level. You may need to turn off the preamps and turn on the attenuator depending on the strength of the AM station.

This completes receiver alignment.



STEP-BY-STEP ASSEMBLY

Receiver Voltage checks

Pin	Voltage (+/-5%)
J5 pin 1	+5.0V
J5 pin 2	-9.5V
J5 pin 4	+11 to +15V
J13 pin 4	9.0V
TP3	>4.0V
U14 pin 1	-5.0V
U13 pin 3	+5.0V
U18 pin 14	+11 to +15V
U19 pin 14	+11 to +15V
U4 pin 8	+4.5V
U4 pin 4	-9.0V
U22 pin 8	+5.0V
Q5 gate 1	+2.0V
Q5 source	+1.9V
Q5 drain	+7.6V
Q20 gate 1	+2.0V
Q20 source	+1.9V
Q20 drain	+7.7V
U25 pin 7	+9.0V
U30 pin 8	+9.0V
U30 pin 4	-5.0V
U5 pin 8	+5.0V
U9 pin 2	+8.5V
U26 pin 7	+8.9V
U7 pin 8	+5.0V
U11 pin 4	+5.0V
U11 pin 11	-5.0V



STEP-BY-STEP ASSEMBLY - Receiver Alignment/Tests

Using remote control

Skip this section if you have a full front panel

- () Temporarily disconnect the 5-pin power cable from the DCD/Tuner board (J10) that goes to the 4-pin connector J5 on the Receiver board (DCDIST-RX – CA51).
- () On the 5-pin connector at the end of CA51, measure the resistance between pin 1 and ground. (Use the exposed metal pins on the side of the connector.) It should be >1K ohms. Now measure the resistance between pin 2 and ground. It should also read > 1K ohms. Finally, measure the resistance between pin 4 and ground. It should read > 150 ohms. Pin 3 is grounded and should read less than 1 ohm. Pin 5 is not connected and should read open. If you measure incorrect values at any of these points, refer to the troubleshooting section of the Service Manual.
- () Disconnect any antennas from the antenna jacks on the Back Panel.
- () Disconnect the TXBF0 cable from the Test Board and reconnect it temporarily to J14 (“To P.A.”) on the DCD/Tuner board. This connects the 10.7MHz transmitter local oscillator to the antenna input, which is also connected to the RXBPF board’s antenna input.
- () Flip switch S1 on the RXBPF board to the “Rcv” position.
- () Reconnect the Receiver power cable to the DCD/Tuner board (J10) and turn on the radio by applying DC power to the APP connectors on the back panel and pushing the on/off switch.
- () Measure the voltages on page 63. If any are incorrect, turn off power, remove the receiver board and check carefully for soldering problems.

Note: The following steps adjust the 71MHz low pass filter, the 9MHz bandpass filter and the FM receiver peaking. Since this signal path is also used to create the 455kHz IF Output, you can also peak the signal using an external panadapter connected to the IF Output jack instead of using the internal IFOut-to-IF4 connection. An RFSpace SDR-IQ receiver is recommended for this, but any spectrum analyzer capable of displaying frequencies around 455kHz can be used. If you choose to do this, do not do the previous two steps. Ignore the voltmeter readings and peak the signal on the panadapter.



- () If using an external PC, connect an RS-232 cable to the DB-9 connector on the back panel.
- () From either the internal or external PC, start a terminal emulation program such as "Hyperterm" and set it for 9600 baud, 8 bits, no parity, 1 stop bit, no handshake.
- () Send the commands:
 - ID; { Sienna responds with "ID710;" }
 - MD4; { FM mode }
 - FA000010700000; { Freq=10.7MHz }
 - CF1; { FM Cal on }
- () Using a small screwdriver, adjust variable inductor L9 ("FM Peak") for a maximum reading on the S-meter. Typically, the coil's slug will be near the bottom (almost fully tightened).
- () Using a small, insulated screwdriver, adjust the 7 trimmer capacitors (in a group to the right of the large roofing filter) so that you see a maximum reading on the S-meter. When properly adjusted, the strong carrier at 10.7MHz should cause a fully quieted signal (no noise) in the speakers.
- () Send the command "CF0;" to turn off FM cal mode.
- () Temporarily disconnect the cable end going to the RF input to the receiver (J14).
- () Set both trimpots on the Receiver Board to their middle position.
- () Send the following commands:
 - MD3; { CW(USB) mode }
 - GT002; { AGC Fast }
 - RG255; { RF Gain max }
- () Touch the red voltmeter lead to TP1 and then send the command "CRnnn000;", where "nnn" is a number from 000 to 255. Send the command repeatedly, increasing the number from 000 until you get a voltage reading of 3.81V. A typical value is 022. Write the value here: _____
- () Send the command:
 - GT004; { AGC Slow }
- () Touch the red voltmeter lead to TP1 and then send the command "CRnnnmmm;", where "nnn" is the number you wrote down from the previous step. Send the command repeatedly, increasing mmm from 000 until you get a voltage reading of 3.81V. A typical value is 012. Write the value here: _____
- () Touch the red voltmeter probe to TP2 and adjust the AGC Threshold pot on the receiver board to get a voltage reading of 4.0V.



The above steps set the Receiver's Automatic Gain Control (AGC) threshold voltage.

- () Touch the red voltmeter probe to TP4 (S Cal) [use the junction of R181 and R187 on Rev B boards].

- () Send the command:

CSxxx;

repeatedly, increasing the number from 000 to 255 until the voltmeter reads 2.1V.

Write the value here: _____

- () Flip switch S1 on the RXBPF board to the "Cal" position.

- () Reconnect the RF cable to J14.

- () Re-enable FM/IF Test mode (CF1;)

- () Send the command: PA2; to turn on both preamps.

- () Touch the red voltmeter probe to pin 1 on J19 (S-meter). Adjust the main tuning dial for a maximum reading. This should coincide with the loudest volume from the loudspeakers.

- () Using a small, insulated screwdriver, adjust the three trimmer caps toward the back of the board, labeled "Roof

peak", "IF1 peak" and "IF2 peak" to achieve a maximum reading on the voltmeter.

- () Adjust variable inductor L5 (IF Peak) for a maximum reading on the voltmeter. Typically, the slug will extend out the top of the can about 1/8". It is not a sharp peak but you should notice when it peaks and then starts dipping again.

- () Send the command:

CBxxx;

repeatedly until the voltmeter reads 1.0 volts. Typical value is 150-210. Write the value here: _____

The above steps calibrate the receiver's RF gain so that a signal at the antenna of 50uV (-73dBm) causes the S-meter to read S9 when using two preamps. It will not be as accurate when using zero or one preamp or the attenuator. Typically, you will want both preamps for frequencies above 14MHz.

- () Remove the TXBFO cable from the DCD/Tuner board and plug it into J8 on the IF Test board in the transmitter compartment.

- () Set the Rcv/Cal switch to "Rcv" on the RXBPF board.



() Connect an antenna to the back panel Receive Antenna input. Select the receive antenna, AM mode and enter the frequency of a local AM station in your area using the commands:
AR2; { Receive antenna }
MD5; { AM }
FA000001000000;
{ For a 1000 kHz frequency }

() Send the command:

CAxxx;

repeatedly until the station is at a comfortable listening level. You may also need to turn off the preamps and turn on the attenuator ("RA01;"). Write the value here: _____

This completes receiver alignment.



STEP-BY-STEP ASSEMBLY-Transmitter Integration

- () If installed, remove the Test board from the transmitter compartment and disconnect all cables from it.
- () Remove the DCD board and install the SWR meter parts (see Appendix C2).
- () Attach CA17 to J3 (“RF Pwr”) on the DCD board. Route it through the top rectangular hole in the front bracket and connect it to J21 (“Tuner”) on the controller board.
- () If you have purchased the antenna tuner, this would be a good time to also install it on the DCD board (see Appendix C3).
- () Build the Transmitter board and attach it to its heatsink (see Appendix H).
- () Build the TXBPF board (see Appendix I).
- () Attach the TXBPF board to the back of the transmitter board using two 4-40 x 3/16” screws. Be sure to carefully align all four connectors. The notches at the tops of the two boards should align with each other.
- () Attach the threaded #4 x 1 1/4” hex female/female spacer to the transmitter using a 4-40 x 3/16” screw.
- () Attach the transmitter extender plate to the large right bracket using a 4-40 x 3/8” screw and a 4-40 KEPS nut. Position the plate so that it stands up vertically above the radio.
- () Rest the back end of the transmitter on the back panel and attach the top of the extender plate to the 4-40 x 1 1/4” spacer using a 4-40 x 3/16” screw. Make sure both 4-40 screws are tight to keep the transmitter from falling.
- () Locate the fan cable. Connect it to J15 (Fan) on the Transmitter board.
- () Attach the 5-pin connector on the end of the DCDIST-TX (CA4) cable to J5 on the Transmitter board. Attach the 3-pin connector to J18 on the Transmitter board.
- () Locate the 4-pin IDC cable coming from the front panel compartment. Connect it to J14 on the Transmitter board.
- () Insert RF cable TXBF0 into J9 (TXBF0) on the Transmitter board.
- () Insert RF cable TXVF0 into J10 (TXVF0) on the Transmitter board.
- () Push the connector on the gray ribbon cable (CONTDATA-TX – CA21) into J1 on the Transmitter board. Fold it



neatly so that it lays flat against the large bracket, then fold it again at right angles to get it into the DCD compartment near the fan. Fold it again and route it through the rectangular hole in the front bracket and push it into J2 (“Tx”) on the controller board.

that is connected between the Main Antenna jack on the RXBPF board and J11 (“To Tx”) on the DCD board. Remove it from J11 on the DCD board, pull it through the opening in the Left Large bracket and reconnect it to J8 (“To RxBPF”) on the Tx board. Route it through the notch on the top of the Tx board.

- () Insert RF cable TX-TUNER/AMP (CA47) into J11 (RF Out). This is the transmitter’s RF output cable. Route it through the hole in the large bracket and into the DCD compartment and insert it into J11 (“To Tx”) on the DCD board. See Detail 7.
- () Connect the 2-pin IDC Microphone cable coming from the front panel to J4 (Mic) on the Transmitter board.
- () Locate RF cable RXBPFMAIN-TX

- () If you have purchased the PC, connect the 2-pin IDC Microphone cable coming from the PC to the connector labeled PCMic on the Transmitter board.
- () Connect the 3-pin IDC cable coming from the receiver to J6 (VOX/Lin) on the Transmitter board.

This completes transmitter integration.

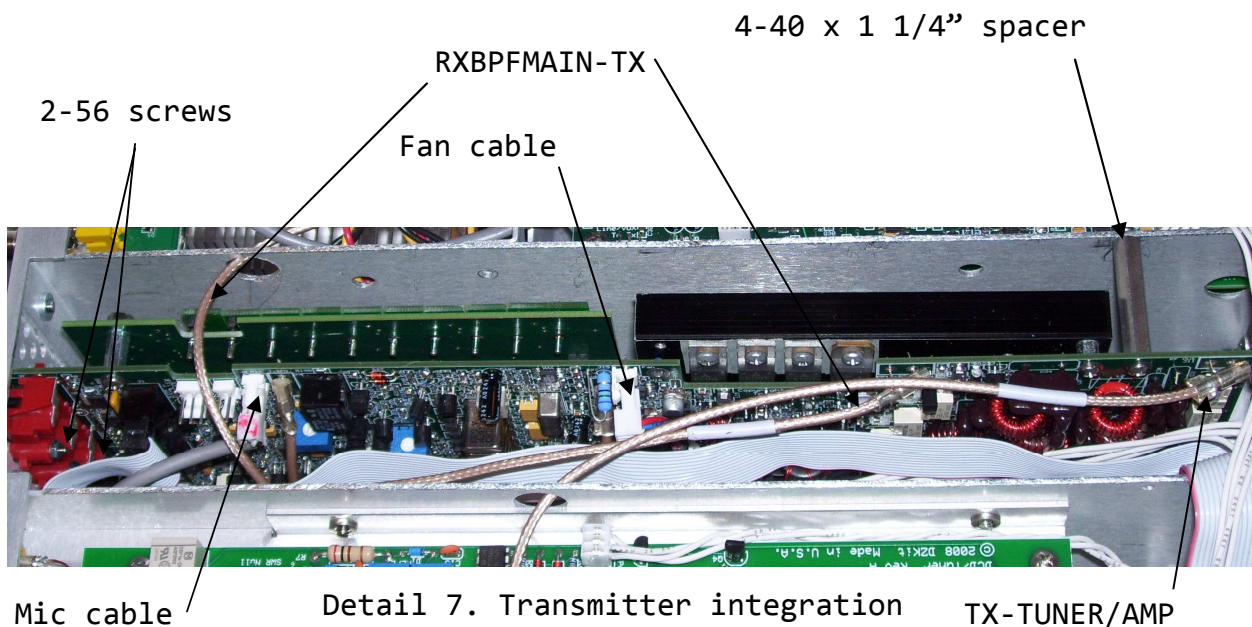



STEP-BY-STEP ASSEMBLY

Transmitter Resistance and Voltage checks

- () Temporarily remove J5 and J18, the two DC power cables going to the transmitter. Using an ohmmeter, verify the following resistances:

J18 pin 1 (right pin) to ground: > 1K
 J5 pin 5 (bottom pin) to ground: > 35K

(Wait until the reading stabilizes, which could take about 30 seconds.)

Tab of power transistors to chassis: Open (should not be shorted to ground. If they are, remove the screws and re-install them as described in Appendix H.

- () Reinstall the power connectors.
- () Remove all jumpers except JP8, which is a 3-pin jumper.

Place JP8 on the left two pins.

- () Turn on power. If you have a full front panel, use the menu to select “Amp” and change its setting from “None” to “Int 10W”. If you do not have a front panel, send the command “PW1;” via the RS-232 port.

All voltages are +/-10%. All references to top, bottom, left and right are with board viewed with phono connectors to your left.

If a measurement refers to a mode (AM, USB, CWUSB, etc.), select that mode by pressing the “Page/Mode” button and rotating the small tuning knob. On units without front panels, use the commands as noted in the chart.

VCC = raw DC input voltage from your power supply (11-15V).

Pin	Voltage	Mode	Mode Commands	Menu setting
J18 pin 1 (right)	5.0V			
J5 pin 5 (bottom)	VCC			
U18 pin 3 (top)	10.0V			
Test Point: CWF	9.5V	CWUSB, CWLSB, FM	md3; md7; md4;	
Test Point: AMSSB	9.5V	AM, USB, LSB, DIGUSB, DIGLSB	md5; md2; md1; md6; md9;	
Test Point: AM-ESSB	9.5V	AM, USB, LSB, DIGUSB, DIGLSB	md5; md2; md1; md6; md9;	ESSB on (es1;)
Test Point: SSB	9.5V	USB, LSB, DIGUSB, DIGLSB	md2; md1; md6; md9;	ESSB off (es0;)
JP12 (top)	5.0V			
JP12 (bottom)	5.0V			
J6 pin 1 (left)	2.5V			



Pin	Voltage	Mode	Mode Commands	Menu setting
JP3 (top)	2.5V			
JP4 (top)	2.5V	USB, LSB, DIGUSB, DIGLSB	md2; md1; md6; md9;	ESSB off (es0;)
U20 pin 1	2.5- 3.5V	USB, LSB, DIGUSB, DIGLSB	md2; md1; md6; md9;	ESSB off (es0;)
U20 pin 2	3.0V			
U20 pin 4	2.5V			
C162 (bottom)	1.8V	USB, LSB, DIGUSB, DIGLSB	md2; md1; md6; md9;	ESSB off (es0;)
U17 pin 1	2.5- 3.5V	As Tx drive is varied Transmitter keyed*	md3; md7; md4;	Tx Drv CW/FM
U17 pin 1	2.5- 3.5V	AM, USB, LSB, DIGUSB, DI- GLSB	md5; md2; md1; md6; md9;	Tx Drv AM/SB
U17 pin 2	3.0V			
U17 pin 4	2.5V			
U8 pin 1	2.5- 3.5V	as RF Power is varied Transmitter keyed*		Tx ALC off (al0;)
U8 pin 2	3.0V			
U8 pin 3	2.5V			
U8 pin 4	2.5V			
JP7 (left)	1.4V	Transmitter keyed*		
Q3 base (left pin)	1.2V	Transmitter keyed*		
Q3 emitter (right pin)	0.4V	Transmitter keyed*		
Q3 collector (center pin)	VCC			
R21, C9 or C133 (top)	9.5V	CWUSB, CWLSB, FM Transmitter keyed*	md3; md7; md4;	
Q4 collector (center pin on 2SC1969)	VCC			
Q5 collector (center pin on 2SC1969)	VCC			
R42 (top)	10.0V	Transmitter not keyed		
R42 (top)	<0.7V	Transmitter keyed*		
D3 or D4 cathode (square pad)	4.3V	Transmitter not keyed		
D3 or D4 cathode (square pad)	4.2V	Transmitter keyed		
Top right pin on K2	<0.8V	Freq < 2 MHz	fa00001800000;	
Top right pin on K4	<0.8V	Freq 2-6 MHz	fa00003500000;	
Top right pin on K6	<0.8V	Freq 6-12 MHz	fa00007000000;	
Top right pin on K8	<0.8V	Freq 12-20 MHz	fa00014000000;	
Top right pin on K10	<0.8V	Freq 20-30 MHz	fa00021000000;	

* Key down in CW modes, PTT pressed in phone modes



STEP-BY-STEP ASSEMBLY

Transmitter, SWR Alignment/Tests—Models with front panels

- () If all voltage and resistance tests passed, install all jumpers and move JP8 to the right two pins.
 - () Connect a dummy load and an RF power meter to the antenna A jack. Connect a key to the front panel (if present) or back panel MANUAL key jack.
 - () Apply power to the radio. If you observe anything out of the ordinary, turn off power at once. With the transmitter installed but not transmitting, you should see no change in anything – the receiver should work, the front panel should light up, and you should not see smoke!
 - () Set the operating privileges to “Extra” by setting the “License Class” entry to “E” in the menu.
 - () Select CW(USB) mode and set the frequency to 1.800 MHz. Select “Fwd Pwr” on the “Meter” entry in the menu. Set the RF Power control counterclockwise (“P- 0.0”). If you are performing this procedure after having already installed the 100W amplifier, set the “Amp” option in the Menu for “Int 10W”, which tells the radio that the amp is not installed. This will cause it to be bypassed for the following tests.
 - () Enable Power calibration by selecting “Tx ALC” in the menu and then selecting “Off”. Select the menu page containing the item “Tx Drv CW/FM” and select that item. Leave this item displayed as you do the next steps.
 - () Press the key. As you do so, gradually increase the RF Power control to maximum (clockwise) and make sure you can get at least 10 Watts out as measured on an external wattmeter. With the RF Power control at maximum, Adjust the “Tx Drv CW/FM” setting until you can get full power out, but do not let the maximum setting of the RF Power control generate more than 13 Watts. Ignore the value shown in the display for power out (e.g., “P- 4.5”).
 - () Repeat the previous step on all other bands, using frequencies of 3.5, 5.3305, 7.0, 10.1, 14.0, 18.068, 21.0, 24.89 and 29.0 MHz.
- Note:** Although the menu setting shows only one setting for “Tx Drv CW/FM”, it actually remembers the drive settings for each band and uses the calibrated value when you change bands.



- () Set the frequency to 14.0 MHz and adjust the RF Power control so that the external wattmeter reads 10.0 Watts when you press the key.
- () Adjust RV1 on the DCD/Tuner board (FWD) until the meter reads as close to 10.0W as possible.
- () Select "Ref1 Pwr" on the meter from the "Meter" menu. Adjust RV2 (REFL) on the DCD/Tuner board to approximately the same setting as RV1.
- () Adjust trimmer C17 on the DCD/Tuner board for as close a reading to 0 as possible.
- () Repeat the previous three steps until the forward power reads 10.0W and the reflected power reads as close to 0 as possible.
- () Release the key. Select USB mode. Set the frequency to 1.9MHz.
- () The next step requires a PTT (Push-to-talk) signal. This can be done by connecting a Yaesu-compatible microphone with a PTT switch to the front panel mic jack or by selecting the "MOX" entry in the menu. MOX is one of five options for keying the transmitter in phone modes, and it is in the PTT/VOX menu option in the center of the bottom row in the display.
- () Key the transmitter by selecting MOX or pushing the PTT switch on the microphone. The S-meter should go to full scale and the receiver should be muted. While listening to your transmitted signal on a nearby receiver tuned to your transmit frequency, Adjust RV1 on the Transmitter board so that the carrier is at a minimum.
- () Select LSB. Re-adjust RV1 for minimum carrier. Alternate between USB and LSB until both modes have equally low carrier. Although you may be able to hear it when monitoring your own signal, the carrier suppression is sufficient that it will not be audible on the air.
- () Key the transmitter and begin speaking into the microphone. As you do so, gradually increase the RF Power control and make sure you can get at least 10 Watts out on voice peaks as measured on an external wattmeter. With the RF Power control at maximum, adjust the "Tx Drv SSB/AM" setting until you can get full power out, but do not let the maximum setting of the RF Power control exceed 13 Watts. Ignore the value shown in the display for power out (e.g., "P- 4.5").
- () Repeat the previous step on all other bands, using frequencies of 3.7, 5.3305, 7.2,



10.1, 14.2, 18.068, 21.3,
24.89 and 29.0 MHz.

Note: Although the menu setting shows only one setting for “Tx Drv SSB/AM”, it actually remembers the drive settings for each band and uses the calibrated value when you change bands.

- () Press the “Proc” button on the front panel. Set the Proc Level control to mid-scale. Select “RF Comp”(compression) as the Meter function. Select “TX Proc Cal” in the menu. Adjust Mic gain and RF Proc controls and Tx Proc Cal” so that the RF Compression reads no higher than 12dB and the signal sounds clean and readable with little distortion.
- () Select AM mode on both the transmitter and the monitor receiver. Select the MOX function or press the PTT switch on the microphone. As you speak into the microphone, verify that your AM signal is readable as an AM signal. Keep the power level less than 3W (30W with 100W amp) on AM.
- () Select FM mode on the transmitter and monitor receiver. Press the PTT button and speak into the microphone. Verify that your FM signal is readable as an FM signal. The default bandwidth of the narrow-band signal is 2.5kHz. If

you plan to use 4 or 5kHz, change it to this in the appropriate menu. Keep the power level less than 3W (30W with 100W amp) on FM.

- () Select TXALC in the menu and change its setting to ON. Now the RF Power control should allow you to accurately set the power level. The displayed value should match that of the external meter.
- () Turn off power.
- () Remove the extender plate from the transmitter. Keep it in a safe place should you ever want to work on the transmitter.
- () Holding the cables out of the way, lower the transmitter into its compartment and align it with the board guide on the bottom. Slide it up against the back panel, feeding the three phono connectors through their holes. Insert two 2-56 x 5/8" panhead machine screws from inside and attach two #2 lockwashers and two 2-56 nuts to the screws on the back panel.
- () Attach the 1 1/4" spacer to large bracket right using a 4-40 x 3/16" screw.

This completes alignment and test of the Transmitter board and SWR meter.



STEP-BY-STEP ASSEMBLY

Transmitter, SWR Alignment/Tests—Models without front panels

- () Connect a dummy load to the antenna A jack via an RF power or SWR meter. Connect a key to the front panel (if present) or back panel MANUAL key jack.
- () From either the internal or external PC, start the “Hyperterm” program and set it for 9600 baud, 8 bits, no parity, 1 stop bit, no handshake.
- () Apply power to the radio. If you observe anything out of the ordinary, turn off power at once. With the transmitter installed but not transmitting, you should see no change in anything – the receiver should work, the front panel should light up, and you should not see smoke!
- () Send the following commands:

```
MD7; { CW(USB) mode }  
FA0000014300000 { 14.3MHz }  
PW1; { 10W Tx present }  
PL000; { 0 RF Proc level }  
PC000; { 0W RF Power level }  
MG128; { Mic Gain=midscale }  
RM7; { RF Power Meter }
```
- () Connect a voltmeter between pin 1 of J25 (“TxMtr”) and ground on the Receiver board. This is the meter output for the selected transmitter measurement function (in this case, Forward Power). Voltages on this pin are never greater than 2V so choose a range on your voltmeter as close as possible to this value.
- () Press the key. As you do so, gradually increase the RF Proc and RF Power functions, alternating between them a little at a time until the output power reaches 5.0W on an external power meter. (In this cal mode, RF Proc controls “Drive” at the first IF frequency, and RF Power controls “Final” amplifier gain at the output frequency.) Use the following commands:

```
PCnnn; { RF Power }  
PLnnn; { RF Proc }
```

where nnn goes from 000 (low) to 255 (high).
- () Now look at the voltmeter reading. Adjust RV1 on the DCD/Tuner board (FWD) until the meter reads as close to 0.833V as possible.
- () Send the command “RM8;”, which selects Reflected Power. Adjust RV2 (REFL) on the DCD/Tuner board until the meter reading dips. Adjust trimmer C17 on that board for



- as close a reading to 0 as possible.
- () Repeat the previous two steps until the forward power reading is 0.833V (5.0W on the power meter) and the reflected power reads 0V (0W).
 - () Release the key.
 - () Send the following command:
MD2; { USB mode }
 - () Set up a nearby monitor receiver to listen to your transmitted signal. If one is not available, send the command "FD;" to put your Sienna into Full Duplex mode, allowing you to hear your transmitted signal. Keep the audio volume low by sending the command "AG010;"
 - () Connect a Yaesu style microphone to the front panel mic jack. Press the PTT button. Adjust RV1 on the Transmitter board so that the carrier (audible tone) is at a minimum.
 - () Send the command "MD1;" (LSB). Re-adjust RV1 for minimum carrier. Alternate between USB and LSB until both have equally low carrier. Although you may be able to hear it when monitoring your own signal, the carrier suppression is sufficient that it will not be audible on the air.
- () Send the following commands:
PR1; { RF Processor on }
PL128; { Level = midscale }
RM2; { Meter = Comp }
 - () While monitoring your signal, Adjust Mic gain and RF Proc controls by sending the commands "MGnnn;" (Mic Gain) and "PLnnn;" (Proc Level) (gradually changing nnn from 128 up or down as necessary so that the voltmeter reads no higher than 1.6V (12dB) and the signal sounds clean and readable with little distortion.
 - () Send the command "MD5;" (AM) on the transmitter and select AM mode on the monitor receiver. Press the PTT button and speak into the microphone. Verify that your AM signal is readable as an AM signal. Keep the power level at less than 3W when using AM.
 - () Send the command "MD4;" (FM) on the transmitter and select FM on the monitor receiver. Press the PTT button and speak into the microphone. Verify that your FM signal is readable as an FM signal. The default bandwidth of the narrow-band signal is 2.5kHz. If you plan to use 4 or 5kHz,



change it to this in the appropriate menu. Keep the power level below 3W when using FM (30W with the 100W amp enabled).

- () Enable TXALC by sending the command "AL1;". Now the RF Power command ("PCxxx;") should allow you to accurately set the power level. The displayed value should match that of the external meter.
- () Turn off power.
- () Remove the alignment plate from the transmitter. Keep it in a safe place should you ever want to work on the transmitter.
- () Holding the cables out of the way, lower the transmitter into its compartment and align it with the board guide on the bottom. Slide it up against the back panel, feeding the three phono connectors through their holes. Insert two 2-56 x 5/8" panhead machine screws from inside and attach two #2 lockwashers and two 2-56 nuts to the screws on the back panel.
- () Attach the 1 1/4" spacer to large bracket right using a 4-40 x 3/16" screw.

This completes alignment and test of the Transmitter board and SWR meter.



STEP-BY-STEP ASSEMBLY-100W PA Integration

Refer to Pictorial 10 and Detail 8 for the following steps.

- () Build the 100W PA Board and attach it to its heatsink (See Appendix J).
- () Remove power from the Sienna.
- () Remove the two screws holding on the Exhaust plate and pull it off.
- () If you have not already mounted the fuseholder to the Exhaust plate, do so at this time.
- () Remove the two screws that hold the DCD/Tuner tray to the large left bracket.
- () Remove the screws, spacer and 6-32 x 2" hex F/F spacer that holds the tray to the chassis bottom.
- () Rotate the tray up 90 degrees and re-insert a 6-32 x 1/4" screw into the front mounting hole and into the left bracket.
- () Place the assembled 100W PA in the chassis with the toroids facing towards the front. Line its mounting holes up with the four 1 1/4" spacers. Attach the PA to the chassis using four 6-32 x 1/4" screws.
- () Disconnect the fan cable from the DCD/Tuner board and re-route it into the amp compartment along the outside edge of the amp. Connect the fan cable to J6 (marked "Fan") on the 100W PA assembly.
- () Locate one 12" 14AWG red wire with a male insulated terminal (tab) on one end and a female terminal (receptacle) on the other. Cut it into three pieces, each 4" long. You will end up with two wires with a lug on one end and one wire with no lugs. Strip the free end of each wire to 1/2" and tin the ends.
- () Solder the tinned end of the wire having the female lug into the pad labeled "V+" on the DCD board. Position the cable over the side of the chassis, through the notch in the side of the tray. Be careful not to let the wire touch the chassis after insertion into the V+ pad.
- () Solder the tinned end of the wire having the male lug into the side lug on the fuseholder. You may need to spring the side lug out slightly first.
- () Insert one end of the remaining 4" wire into the bottom

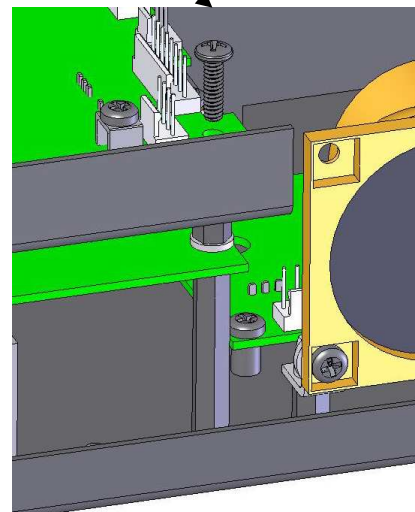
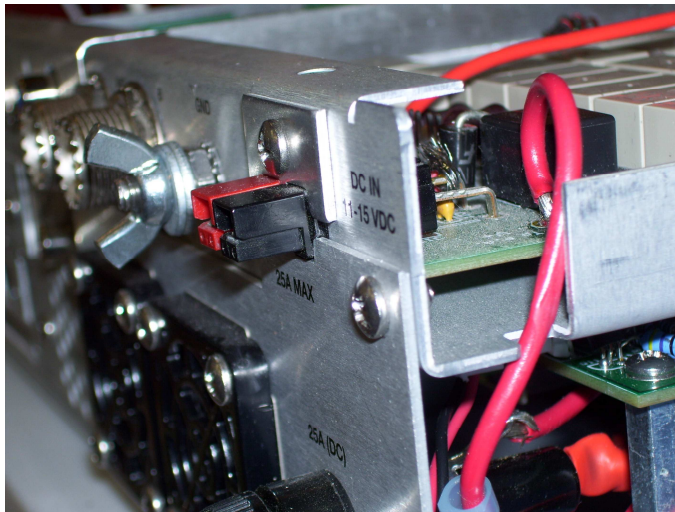
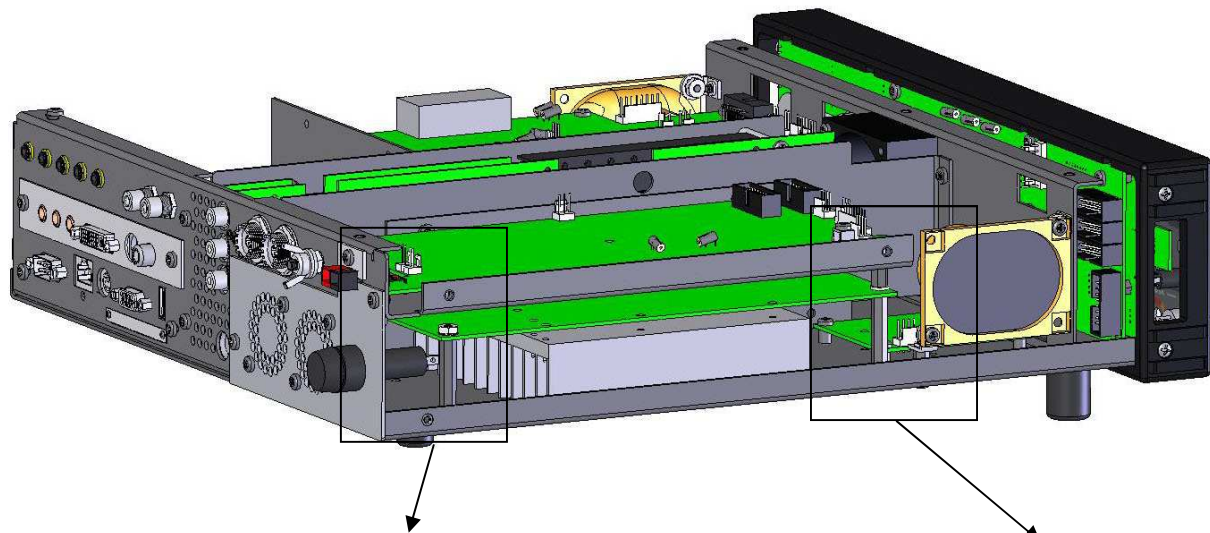

Pictorial 10. 100W PA Mounting

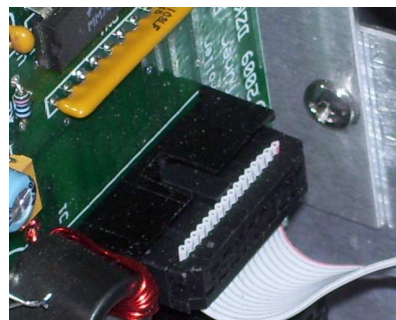
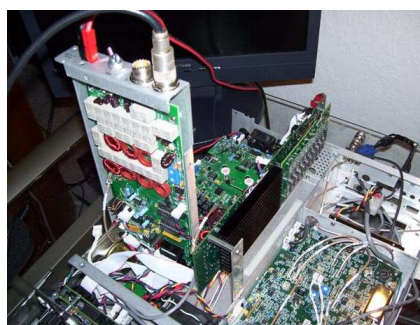

Detail 8. Photos of vertical tray mounting



side of the 100W PA Board into the pad marked W1 (“From Fuse”). Solder the other end to the end lug on the fuseholder. Bend the wire so that it does not touch the heatsink.

- () Locate the other 12” 14# wire with a male lug on one end and a female on the other. Plug the male end into the 4” cable coming from the DCD/Tuner board. Plug the female end into the cable that is attached to the fuseholder.

Note: Once the tray is lowered into its normal position (after test), this extender cable will be removed and the other cables connected together. This minimizes wire length for this high current wire.

- () Locate a CA15 2-pin MTA cable. Connect one end to J19 (“Amp”) on the Controller board. Route the other end of the cable through the lower rectangular opening on the

left side of the front bracket and connect the end to J1 (“PA Curr”) on the PA board. Dress this cable between the board and the heatsink so that it won’t get pinched by the top cover when it is attached later.

- () Remove the end of the TX-TUNER/AMP RF cable (CA47) that is connected to J11 on the DCD/Tuner board. Feed this cable through the lower hole in the large left bracket and connect it to J4 (“Tx In”) on the 100W PA Board.
- () Insert a short gray ribbon cable between J6 (“To PA”) on the DCD/Tuner board and J3 on the 100W PA board. This cable goes underneath the other one that is connected to J2 on the DCD board.
- () Connect RF cable AMP-TUNER (CA49) between J2 (“Antenna”) on the 100W PA board and J4 (“From PA”) on the DCD/Tuner board. Dress this cable around the front end of the tray.



100W PA Alignment/Tests

Note: If your results are different from the expected ones, refer to the troubleshooting guide in the Service Manual.

- () Using an ohmmeter, measure the resistance between V+ (W1 – "From Fuse") and ground. It should be > 1500 ohms.
- () Turn trimpot RV1 ("PA Bias") all the way *clockwise* (right).
- () Connect power to the Sienna DC input terminals and turn on the unit. If you smell smoke or observe power cycling on and off, switch the power off.
- () Using a voltmeter, measure the voltage on TP3. It should read 5.0V +/- 0.15V.
- () Verify that the fan is running at low speed. If you have a heat gun (a hairdryer will work), blow some heat on thermistor TH1, aiming at the bottom of the board. When the temperature rises enough, the fan should switch to high speed. You can hear the difference as it runs faster. As the temperature cools back down, it should switch back to normal, low speed. If low speed is too low and/or the fan appears "stuck", replace R35 with a short.

If you have the full front panel (SF-100x models):

- () Press the MENU button and then use the small knob to select the menu item labeled "Tx/Amp". Press the PAGE/MODE button to disable paging, or simply rotate the large knob off of the selection and back on it, then rotate the small knob until the selection reads "Int 100W". Press MENU again to exit MENU mode.

() Press the BAND button and then use the large knob to cycle through the bands. As you do so, you should hear the low-pass filter relays K4-K13 switch on and off.

The relays on the transmitter board also change when the bands are changed, so listen carefully to be sure the ones on the amp are also changing.

- () Set the mode to CW(USB) and the frequency to 14.000 MHz and connect a dummy load rated for 100W to antenna jack A. Be sure Antenna A is the one selected.



If you have a remote-control-only version (S-100xx) of Sierra:

() Connect to Sierra using Hyperterm or other RS-232 control program.

() Enter the following command to enable the 100W amp:

PW2;

() Enter the following commands. After each one, you should hear the low-pass filter relays K4-K13 switch on and off:

FA00001800000;

FA00003500000;

FA00007000000;

FA00014000000;

FA00021000000;

The relays on the transmitter board also change when these commands are used, so listen carefully to be sure the ones on the amp are also changing.

() Select CW(USB) and leave the frequency set to the 20M band by sending:

MD3;

FA00014000000;

() Connect a dummy load rated for 100W to antenna jack A. Make sure antenna A is selected by sending:

AN1;

() Short TP2 to ground using a clip lead or insulated wire. Measure the voltage at TP1 ("100V Back Bias"). It should read 100V +/-5V. Remove the clip lead. The voltage on TP1 should return to about 12V.

() Place a voltmeter on test point TP4. Slowly adjust pot RV1 ("Bias") until the voltage reads 0.1V +/-0.02V. This sets the Class AB bias level such that each RF power transistor draws about 320mA of collector current. If you have a front panel, you can see the "PA Curr" value in the voltage/current monitor menu page. A reading of 0.6 to 0.7 Amps is normal.

() Insert a key into the Manual key jack and key the rig. Adjust the RF Power control for 100W and verify that the RF Power meter shows 100W output. If you have an external meter, that should also show 100W out. The TxALC menu option should be ON ("AL1;").

() Change bands and verify that all bands have full power out.

() Turn off the radio and remove the power.

() Remove the end of the RXBPF-MAIN-TX/AMP RF cable (CA33) from J8 ("To RxBPF") on the



Transmitter board. Pass it through the rectangular hole in the back of the large left bracket and connect it to J5 ("To RxBPF") on the 100W amp board.

- () Remove the 6-32 x 1 1/2" screw from the left front corner of the board.
- () Remove the screw holding the tray upright, lower the tray back down and reattach it to the left bracket using two 6-

32 x 1/4" screws.

- () Insert the 6-32 x 1 1/2" screw into the left front corner of the DCD/Tuner board, into the spacers. Tighten it.
- () Re-attach the Exhaust plate to the back panel using two 6-32 x 1/4" screws.

This completes installation of the 100W PA Option.



STEP-BY-STEP ASSEMBLY-Final Assembly

- () Secure the front panel to the bottom chassis using four 6-32 x 1/4" screws (one or two should already be in place on the bottom).
- () Place the top cover on the radio and secure it to the chassis using eleven 6-32 x 1/4" flathead black anodized screws.
- () If you have a model with a full front panel, install all knobs. Use the provided 1/20" (.050") hex key to tighten the small knobs, the 1/16" (.063") hex key to tighten the large tuning knob, and the 5/64" (.078") hex key to tighten the small tuning knob. Small knobs have pointers on them. Be sure to first rotate the control counterclockwise to its stop and position the knob with the pointer at about the 7:00 position so that one of the two setscrews hits the flat in the shaft.
- () Affix the serial number sticker to the back panel between the LINE OUT and IF OUT connectors.

This completes assembly and test of the Sienna transceiver.





Appendix A: PC Power Wiring



The optional UPS (Uninterruptible Power Supply) board switches automatically between normal unswitched power from the DCD and a backup battery (not provided; place one in the compartment below the DCD board). If present, it then connects to the mini-ATX power supply which in turn provides power for the PC. This option is not recommended when you have the 100W amp installed, as there is no place to put a backup battery.

The UPS board mounts directly on the Sienna chassis in the compartment in front of the DCD board (rev C chassis) or on a small daughter board that mounts to the chassis (rev B chassis).

If you have purchased the UPS board:

- () For rev B chassis: Attach the UPS to the daughter board first, using four 4-40 x 1/2" hex male/female spacers and four 4-40 KEPS nuts.
- () Mount either the daughter/UPS assembly to the chassis using four 6-32 x 1/4" screws (rev B) or mount the UPS to the chassis directly using four 4-40 x 1/4" screws (rev C).
- () Attach a battery to the BAT+ (Red) and BAT- (Black) terminals on the UPS using the provided wires with quick disconnect terminal lugs on the ends.



Parts provided with PC

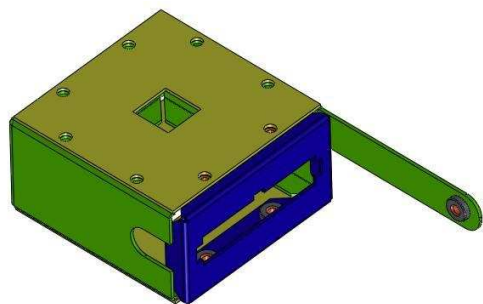

Steel RFI shield
(2 pieces)



Power adapter
(Supplied with
PC)



PC



2 jack screws



2 4-40 x 1/4" screws
6 6-32 x 1/4" screws

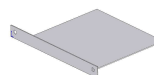

CF Mounting tray



2 #1 screws

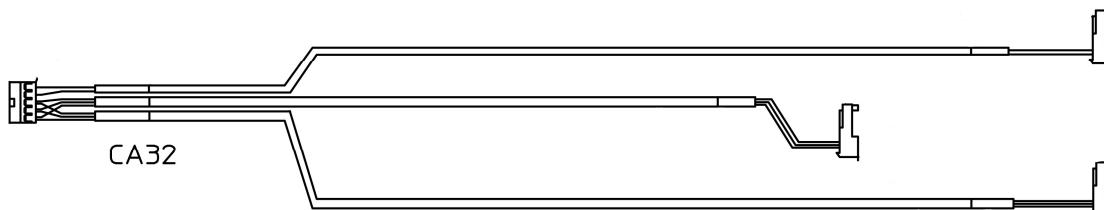

CA32



#6 solder lug

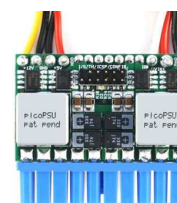

Mini-ATX Power Supply

CA6





PC Power Supply Integration

- () Insert the 20-pin white connector on the power adapter into the small sheet metal bracket (Shown in blue or darker color on previous page).
- () Attach the mini-ATX supply to the 20-pin connector.
- () Attach the outer steel shield cover to the housing using four 6-32 x 1/4" screws. Be sure to dress the cables through the openings at the bottom and side of the cover as shown in Photo A1.
- () Secure the assembly to the small bracket using two 6-32 x 1/4" screws.
- () Connect the quick disconnect terminals to the three cables that you placed in the PC compartment on an earlier step. Match red to red, black to black and white to white. (Note: a planned enhancement to this circuit will add a switch in series with the white wire. If you have this switch, it will be connected to the back panel. Attach the white wires to this switch; either wire can be connected to either terminal on the switch.)
- () Plug the two-pin connector into the PC motherboard as shown in Photo A1, with the black lead toward the back of the radio.
- () Plug the white 12-pin connector into the PC motherboard.
- () Dress the cables neatly inside the PC compartment.
- () Cable CA6 is shipped with extensions on the red and black wires. Locate those wires. If you did *not* install the UPS, leave them attached to CA6 but cut the female quick disconnect terminals off of the other end of the extensions, strip them to 3/16" and tin them. If you *did* install the UPS, remove the extensions from CA6.
- () If you installed the UPS, connect the red and black quick disconnect terminals on CA6 to the VOUT and GND terminals on the UPS.
- () If you installed the UPS, attach the female ends of the red and black wires you just removed to the VIN and GND terminals on the UPS. Clip the male quick disconnect terminals off the other ends of the red and black wires, then strip the ends to 3/16" and tin them.
- () Solder the stripped and tinned red wire to the pin



connected to the red Anderson Powerpole connector at J12 on the DCD board. (Note: Rev B DCD boards have a pad for this labeled "Unsw to PC".) Dress the cable neatly along the left side of the DCD tray.

- () Solder the stripped and tinned black wire to a #6 solder lug. Remove the screw

in the front left corner of the DCD board and insert the solder lug, then re-tighten the screw.

- () Connect the 4-pin MTA connector on CA6 to J8 on the DCD board. Only one terminal is used.

This completes installation of the PC power supply.

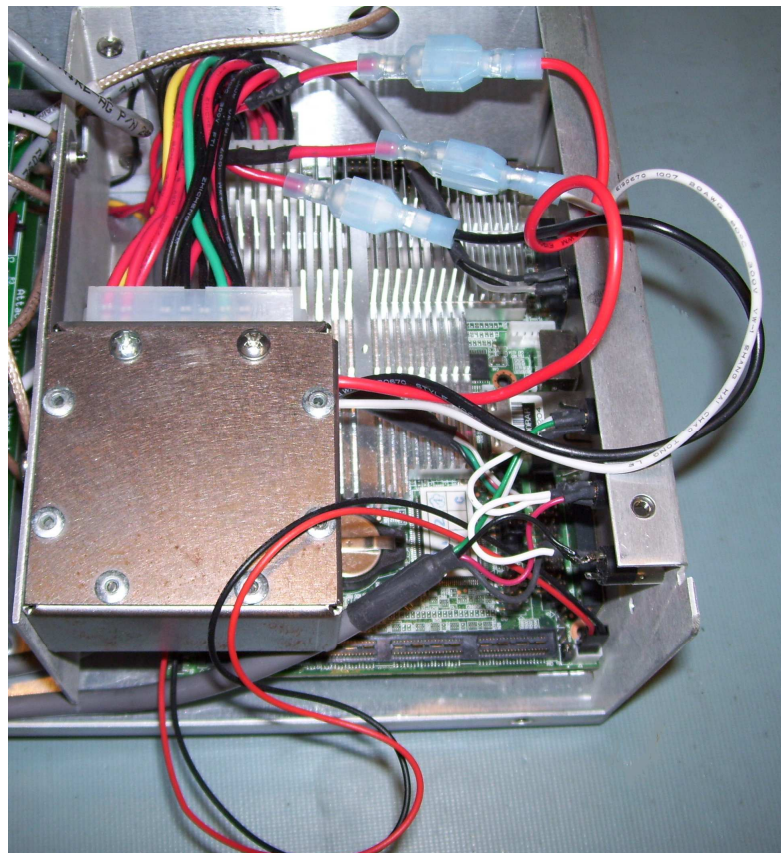

Photo A1. ATX Shield mounting



Appendix B: RS232 Board

PARTS LIST

Item	Part	Description	Qty
1	J1	14-pin 2mm connector	1
2	J2	DB-9 PC-mt right-angle connector (male and female)	1
3	R1,R2,R3,R4,R5	100 ohm 1/8W resistor	5
4	C1,C2,C3,C4,C5	150pF monolithic capacitor	5
5		RS232 Board blank	1

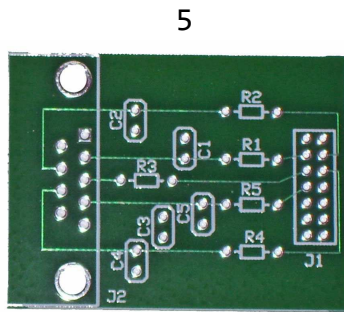

RS232 Board, blank

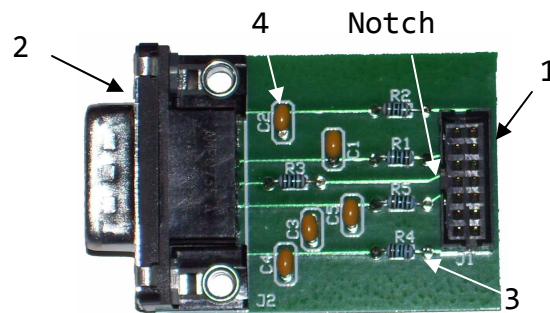

RS232 Board, assembled



STEP-BY-STEP ASSEMBLY-RS232 Board

- () Load and solder all resistors. Clip the leads.
- () Load and solder all capacitors. Clip the leads.
- () Load and solder the 14-pin rectangular connector. The side with a notch faces inward (See note on photo.)
- () Load and solder the 9-pin D-subminiature connector. If you want a male connector facing out the back panel, load the *male* DB9 connector to the top (component side) of the RS-232 board and install the board with components facing up. If you do this, you will most likely

need a "gender changer" on the connector, because most RS-232 cables have male connectors on them. If you want to avoid the use of the adapter, load the *female* DB9 connector to the **BOTTOM** (circuit side) of the board and install the board upside down. Note that the connector that the controller interface cable attaches to will now be upside down. A male and female DB9 connector have been provided in the kit.

This completes assembly of the RS-232 Board. This board is only used when no PC is installed in the Sienna.



Appendix C1: DCD/Tuner Board [DCD Section]

PARTS LIST

Item	Part	Description	Qty	Bag Nr
1	C3 C4 C16 C18 C19 C21 C25 C26 C28 C30 C31	.1uF 50V monolithic X7R 5%	11	1
2	C1 C2 C20 C22 C23 C29	100uF/25V 20% aluminum electrolytic	6	1
3	C24 C27	22uF/25V tant "D" 1 ohm ESR	2	1
31	R28	165K ohm 1/8W 1%	1	1
4	D8 D11 D12	1N4007B 1000V rectifier diode	3	2
4	D5 D9	1N5223B-2.7V Zener diode	2	2
4	D7	1N5711 Schottky diode	1	2
4	D10	1N5818 Schottky diode	1	2
5	D6	1N5404 power rectifier	1	2
6	F1	9A PTC Resettable fuse	1	2

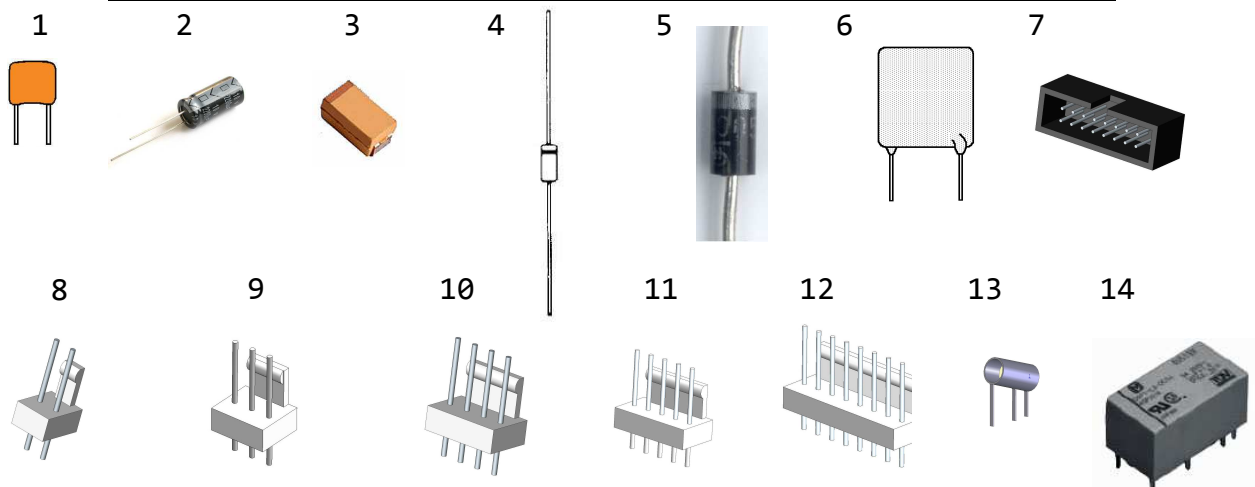



Item	Part	Description	Qty	Bag Nr
31	R12 R19 R23 R27	1M ohm 1/8W 1%	4	2
7	J2 J1	16-pin 2-row .1" centers shrouded male header	2	3
8	J5 J6	2-pin .1" centers male keyed header	2	3
9	J9	3-pin .1" centers male keyed header	1	3
10	J8	4-pin .1" centers male keyed header	1	3
11	J10 J4	5-pin .1" centers male keyed header	2	3
12	J7	8-pin .1" centers male keyed header	1	3
13	J11 J14	Taiko-Denki RF jack PCB	2	3
22		Anderson Powerpole contact, right angle PCB mount	2	3
23	J12	Anderson Powerpole connector - red	1	3
23	J13	Anderson Powerpole connector - black	1	3
14	K17 K18	DSP1A-DC12	2	4
15	K19	ET1 25A SPDT Relay	1	4
16	L8 L9	47uH shielded/ferrite	2	4
17	RFC1	Type 77 Toroid	1	4
18	RN1	Resistor network, .1" centers, 10-pin 10K	1	4
19		Screw - 4-40 x 1/4" PH Phillips M/S	2	4

15



16

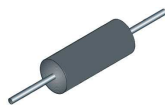

17



18

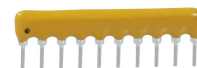

19



20



21



22



23



24

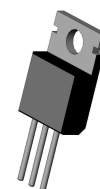



Item	Part	Description	Qty	Bag Nr
20		4-40 shoulder washer	2	4
21		TO-220 insulator	2	4
		Magnet wire, red 24AWG (inches)	8	4
24	Q1	TIP41C power transistor TO-220	1	5
25	Q2 Q4 Q5	2N7000 MOSFET	3	5
29	U10	MAX765 8-pin DIP	1	5
26	U2	74HC273 octal D flip-flop 20-pin DIP	1	6
27	U4	ULN2803 relay driver 18-pin DIP	1	6
28	U6	LM339 quad comparator 14-pin DIP	1	6
29	U7	LM393 dual comparator 8-pin DIP	1	6
30	U8	AP1084-5 5V regulator TO-220 ("84-50")	1	6
30	U9	LM2940CS-9 9V regulator TO-263	1	6
32	R29 R30	47 ohm 1W small metal oxide 5%	2	5
31	R20	100 ohm 1/8W 1%	1	7
32	R26	470 ohm 2W small metal oxide 5%	1	7
31	R8 R18 R21 R22	1K ohm 1/8W 1%	4	8
31	R10 R17	3.3K ohm 1/8W 1%	2	9
31	R25	4.7K ohm 1/8W 1%	1	10
31	R1 R2 R9 R14	10K ohm 1/8W 1%	4	11
31	R3 R11 R13 R24	22K ohm 1/8W 1%	4	12
33		Blank DCD Board	1	13

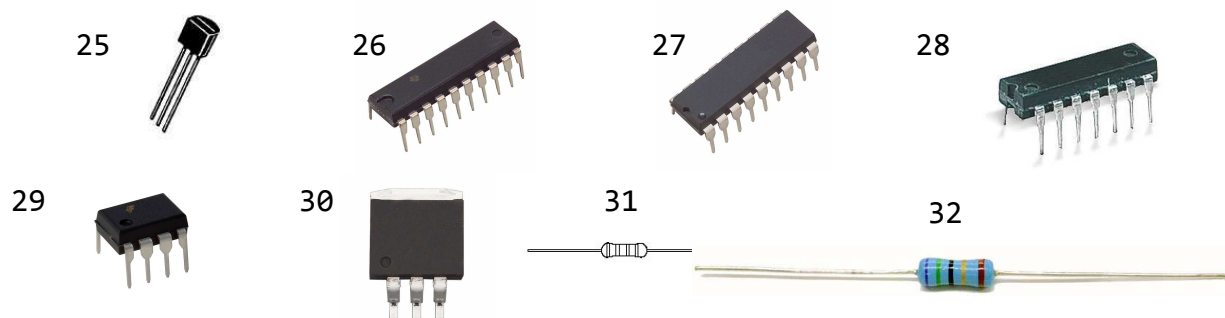



33

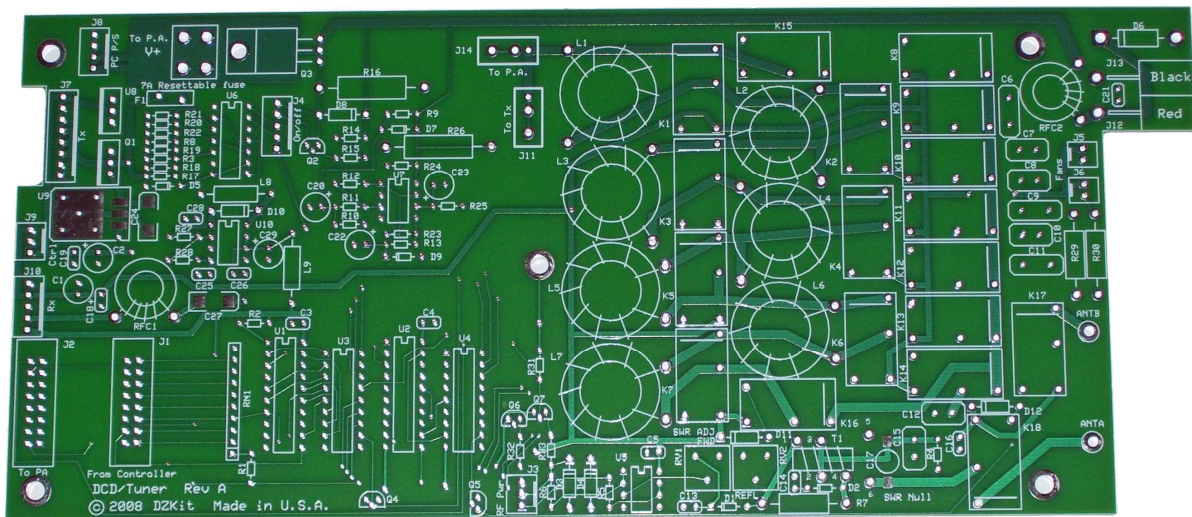



STEP-BY-STEP ASSEMBLY-DCD Board

Highlight or check off each part on the parts list that came inside the bag as you install it on the board. Unless otherwise instructed, load all parts of the same type from each bag and clip the leads after soldering.

- () Load and solder all capacitors, one bag at a time, including electrolytic capacitors, being careful to observe polarity (see page 8).

Note: The tantalum electrolytics C24 and C27 mount with the stripe aligned with the angled side of the silkscreen:

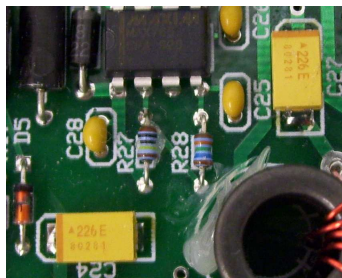

- () Load and solder all resistors, one bag at a time. Clip the leads. Note that some resistors are in bags that also contain other parts.
- () Load and solder all diodes, one bag at a time, being careful to observe polarity (page 8). The side with a band (the cathode) goes in the square pad. Note that some diodes are in bags that also contain other parts.

Note that D6, the large 1N5404, mounts vertically; place it with the band down and bend the lead over and into the round pad:



- () Load and solder inductors L8 and L9.
- () Load and solder F1, the 9A Resettable fuse. Bend this part over at a 45 degree angle so that it does not hit the top cover when it is installed.
- () Load and solder the resistor network. Be sure that the side with the dot goes into the square pad.
- () Load and solder Q2, Q4 and Q5. Line up the flat side of the transistor with the flat side of the silkscreened outline. Spread the transistor leads apart as you insert the part into the board. The parts should be inserted until the bottom of the plastic transistor body is about .1" off the board.
- () Insert the right angle Anderson Powerpole (APP) contacts



into the red and black bodies:

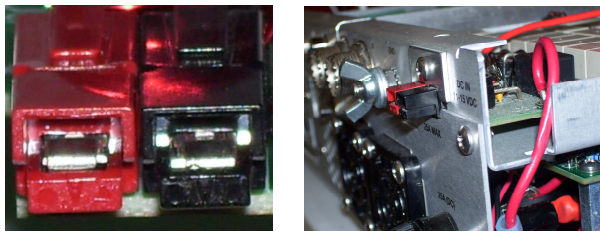

Right picture shows how APP connectors will look when attached to the DCD tray.

- () Attach the APP connectors together with the red and black bodies in the orientation labeled on the board. Position the connectors so that their bodies match the outline on the board, then bend the leads down. Load and solder the connectors to the board. Clip the excess leads off on the bottom of the board.
- () Wrap five turns of #22 magnet wire around Toroid RFC1. Insert the toroid into the board with the cylinder facing vertically. Solder the leads. Maintain heat for about 1 minute, long enough to melt the coating and cause solder to flow onto the lead and the pad. Be sure your soldering iron is set to at least 750 degrees. Clip any excess leads. Using an ohmmeter, verify that there is continuity from one pad to the other. If not, reheat the connections.
- () [If you plan to install the antenna tuner parts \(see Appendix C3\) during initial assembly of this board, skip the next step.](#)
- () Cut a 4" length of magnet wire. Insert one end into the bottom pad of L7 with about 1/2" extending out the bottom of the board. Insert the other end into the top pad of L1 and pull the wire taut. Solder both ends using magnet wire soldering procedures described earlier.
- () [If you plan to install the SWR meter parts \(provided with the transmitter, see Appendix C2\) during initial assembly of this board, skip the next step.](#)
- () Place a 1" length of bare wire in the holes marked "5" and "6", next to transformer T1. Solder the wires as described earlier and clip extra lead length.
- () Load and solder relays K17, K18 and K19. They will only go in one way.
- () Place U9, an SMT regulator, on the board where marked. Hold it in place while soldering one pin, then solder the other two pins. Finally, heat the tab and apply solder until it flows evenly along the bottom and sides of the tab. Apply solder to the five pads beneath the part on the bottom of the board too.
- () Load and solder all remaining



Integrated Circuits *except U8*, one bag at a time. Make absolutely sure that the ICs are inserted with pin 1 oriented correctly. When holding an IC horizontally so that you can read the printing from left to right, pin 1 is in the lower left corner. It is often marked with a dot, and there is also often a notch on that side of the IC. Pin 1 goes in the square pad on the board. Be especially careful when loading U5 and U7, since they look alike.

- () Load and solder connectors J1 and J2. Pin one of these connectors is marked with an embossed triangle on one side. Line this up with the square pad. The side with a single notch faces the resistor network. Be sure the connectors are flush with the board.
- () Load and solder the two RF connectors, J11 and J14. These connectors are mounted at a 45 degree angle. First bend the end pin down, compress the two larger pins slightly, and push the connectors into the holes. It is OK for the body of the part to touch the board—it will not short out the center conductor.
- () Load and solder all other connectors *except J3*, which is included with the SWR kit. Be sure to align the tab on the white AMP MTA connectors

with the thick silkscreened bar. Be sure the connectors are flush with the board.

- () Clip the pins of 8-pin connector J7 as close as possible to the board.

Note: In the next two steps, be sure that these regulators are mounted to the **BOTTOM** side of the board.

- () Bend the leads of U8 **up** 0.8" from the end of the tab. Insert U8 from the *bottom* of the board, such that the bottom of the tab is 1/4" from the bottom of the PC board. Solder only one pin, just enough to keep the part from falling out. It will be secured to the chassis when the board is installed.
- () Repeat the previous step with Q1 (again, mounting it on the *bottom* of the board). Since Q1 and U8 look alike, be sure the right part is placed in the right location.
- () Check your work. Pay particular attention to connectors and ICs, making sure that every pin is soldered. Hold the board at an angle and make sure all leads have been clipped.

This completes construction of the DCD (DC Distribution) portion of the DCD/Tuner board.

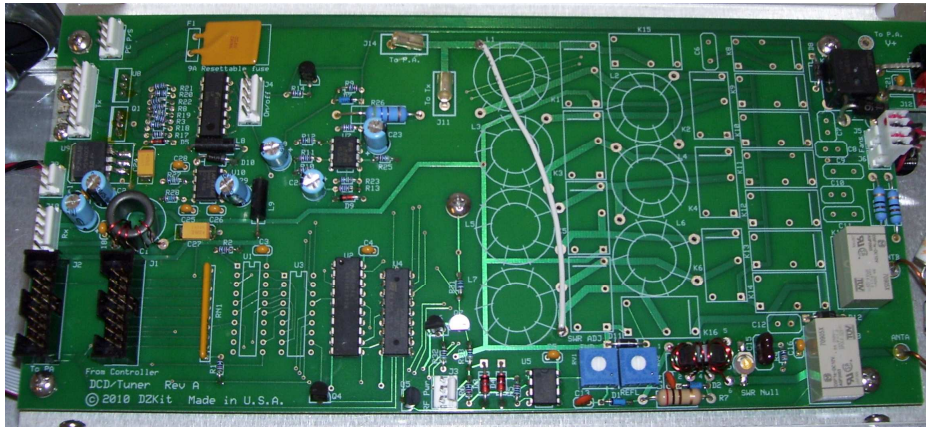

DCD Board, front, tuner section not installed, SWR meter installed

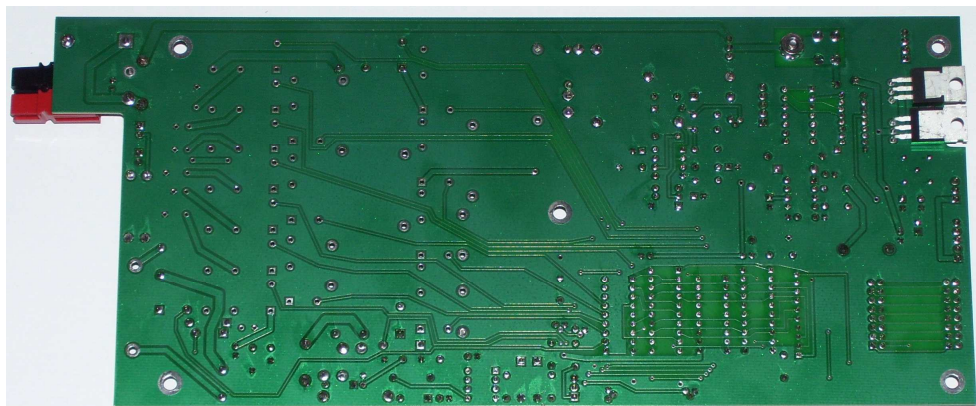

DCD Board, back, tuner section not installed, SWR meter installed



Appendix C2: DCD/Tuner Board [SWR Section]

PARTS LIST

Note: These parts are included with the transmitter board

Item	Part	Description	Qty
1	D1, D2	1N5711 Schottky diode (blue)	2
1	D3, D4	1N4733A 5.1V 1W Zener diode (red)	2
2	T1	FT50-43 toroid	1
3	C5	.1uF monolithic capacitor	1
4	C13, C14	1000pF ceramic disk capacitor	2
5	C15	100pF silver mica capacitor	1
6	C17	30pF trimmer capacitor	1
7	RV1, RV2	100K top adjust trimpot	2
8	U5	LM358 dual op-amp	1
9	R7	200 ohm 1W	1
10	R4	3.3K ohm	1
10	R32, R33	4.7K ohm	2
10	R5, R6, R31	10K ohm	3
11	Q6, Q7	2N7000 MOSFET	2
12	J3	3-pin AMP MTA male keyed header	1
		Bare wire 18# (inches)	6
		Magnet wire - 24# red (inches)	12
		Magnet wire - 24# green (inches)	12

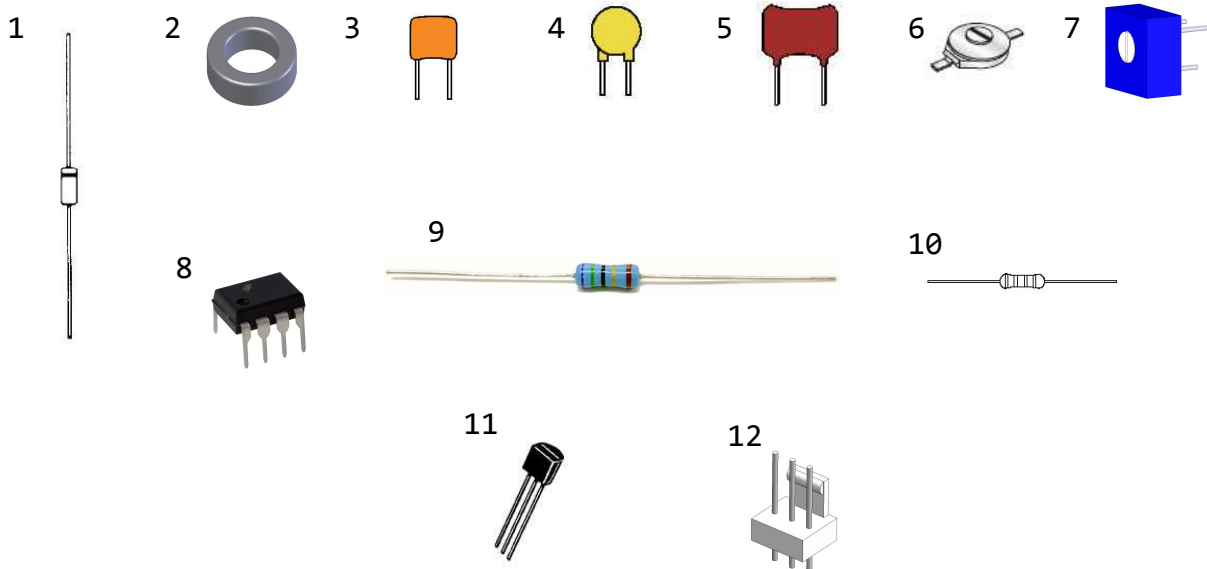



- () Load and solder all capacitors, including C17, the 30pF trimmer capacitor. The trimmer can be installed either direction.
- () Using an ohmmeter, measure the six resistors and sort them by value. Load and solder them at their appropriate place. Clip the leads.
- () Load and solder all diodes, one bag at a time. Note that some diodes are in bags that also contain other parts.
- () Load and solder the trim pots, RV1 and RV2.
- () Load and solder U5, the LM358 8-pin DIP. Be sure pin 1 goes into the square pad.
- () Load and solder Q6 and Q7. Spring the leads slightly when inserting these transistors, and make sure the flat side of the transistor lines up with the flat side on the silkscreen.
- () Load and solder J3, the 3-pin MTA connector. Be sure the side with the vertical tab is aligned with the thick white bar on the silkscreen.
- () Cut two lengths of #24 magnet wire 10" in length. Fold 1/4" of both ends of one wire back onto itself. Twist the two wires together, about 2 turns

per inch. Wrap twelve turns of the finished wires around toroid T1. Insert the toroid into the board with the unfolded leads going into pins 1 and 2 and the folded leads into pins 3 and 4 (after unfolding them so they fit in the holes). Follow soldering instructions given in the previous step. See detail C2-1.

- () Cut 1 1/2" of 18# magnet wire. Insert the wire through toroid T1 and solder the ends to pins 5 and 6. (If you earlier installed a wire between pins 5 and 6, remove it before installing T1.)

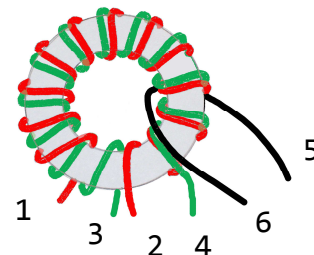

Detail C2-1. T1 construction (2nd winding shown in green for clarity)

- () Check your work. Pay particular attention to connectors and ICs, making sure that every pin is soldered. Hold the board at an angle and make sure all leads have been clipped.

This completes assembly of the SWR section of the DCD/Tuner board.



Appendix C3: DCD/Tuner Board [Tuner Section] (Option 102)

PARTS LIST

Item	Part	Description	Qty
1	K1-K16	SPST 12V relay, 8A	16
2	C12	10pF silver mica (sm)	1
2	C11	20pF sm	1
2	C10	39pF sm	1
2	C9	82pF sm	1
2	C8	150pF sm	1
2	C7	330pF sm	1
2	C6	560pF sm	1
3	L1-L7	T80-2 Toroid	7
4		20# magnet wire	10'
5	U1	74HC273 octal D flip-flop	1
6	U3	ULN2803 relay driver	1

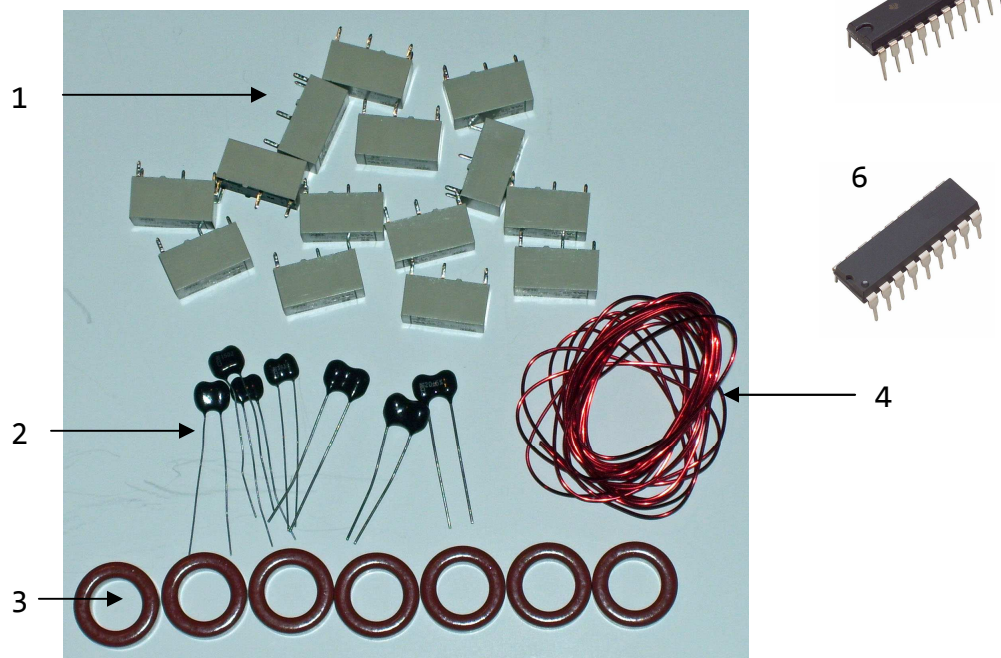

Note: Capacitors are marked with actual value, e.g. "330", in pF.



STEP-BY-STEP ASSEMBLY-Tuner Board

Note: Be very careful not to let your soldering iron touch plastic parts on the DCD board as you install these parts.

- () If you are installing this option after you finished wiring your Sienna, first disconnect power, remove all cables and screws from this board, remove the Fan mounting bracket, remove the nuts holding in the two SO-239 connectors and the ground lug, and pull the DCD/Tuner board out of the unit. Also unsolder the wire that runs diagonally across the board.
- () Wind 31 turns of 20 gauge magnet wire around toroid L1. See detail photo on next page. Each time the wire enters the toroid counts as one turn. Leave about 1/2" lead exposed. Do not space the leads evenly around the core – wind them tightly together. See photo of assembled unit.
- () Load and solder the toroid where noted on the board. Be sure it lies flat on the board and tighten the leads as much as possible. Once the board has been tested, you will apply a small amount of glue to keep the toroids from moving, but it is not necessary to do so at this time. Apply heat to each lead for at least one minute to be sure that the coating melts off and the lead is securely soldered to the board. Then clip excess leads.
- () Wind 22 turns of magnet wire around toroid L2. Solder the toroid in place.
- () Wind 15 turns of magnet wire around toroid L3. Solder the toroid in place.
- () Wind 10 turns of magnet wire around toroid L4. Solder the toroid in place.
- () Wind 5 turns of magnet wire around toroid L5. Solder the toroid in place.
- () Wind 3 turns of magnet wire around toroid L6. Solder the toroid in place.
- () Wind 2 turns of magnet wire around toroid L7. Solder the toroid in place.
- () Load and solder all silver mica capacitors. Clip the leads.
- () Load and solder all 16 relays.
- () Load and solder both ICs, making sure pin 1 goes into the hole with the square pad.
- () Using an ohmmeter, verify continuity (< 1 ohm) between the two pads that each toroid's wires are soldered to.



If any do not read correctly, re-heat the connections making sure that all enamel is removed.

- () Check your work.
- () If this is an upgrade, reinstall the board and reconnect cables.

This completes assembly of the Tuner section of the DCD/Tuner board.

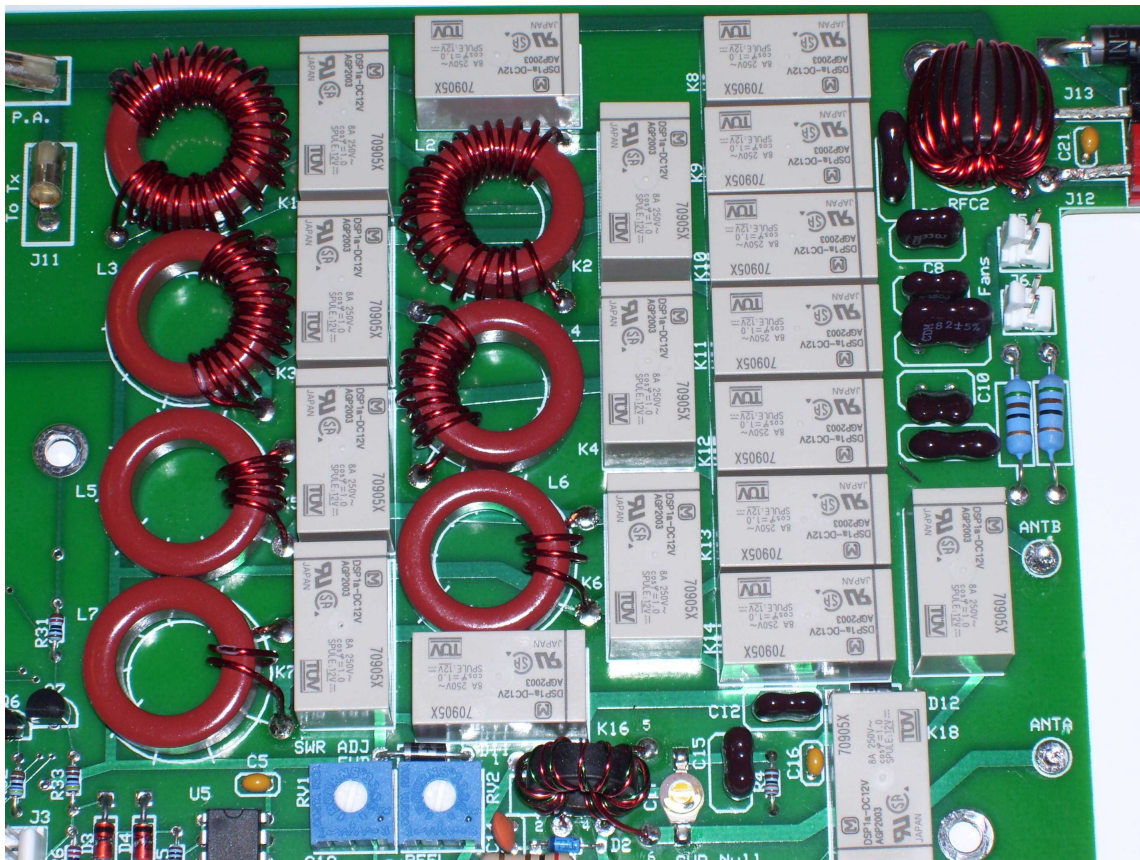

Detail photo showing correct winding of tuner toroids

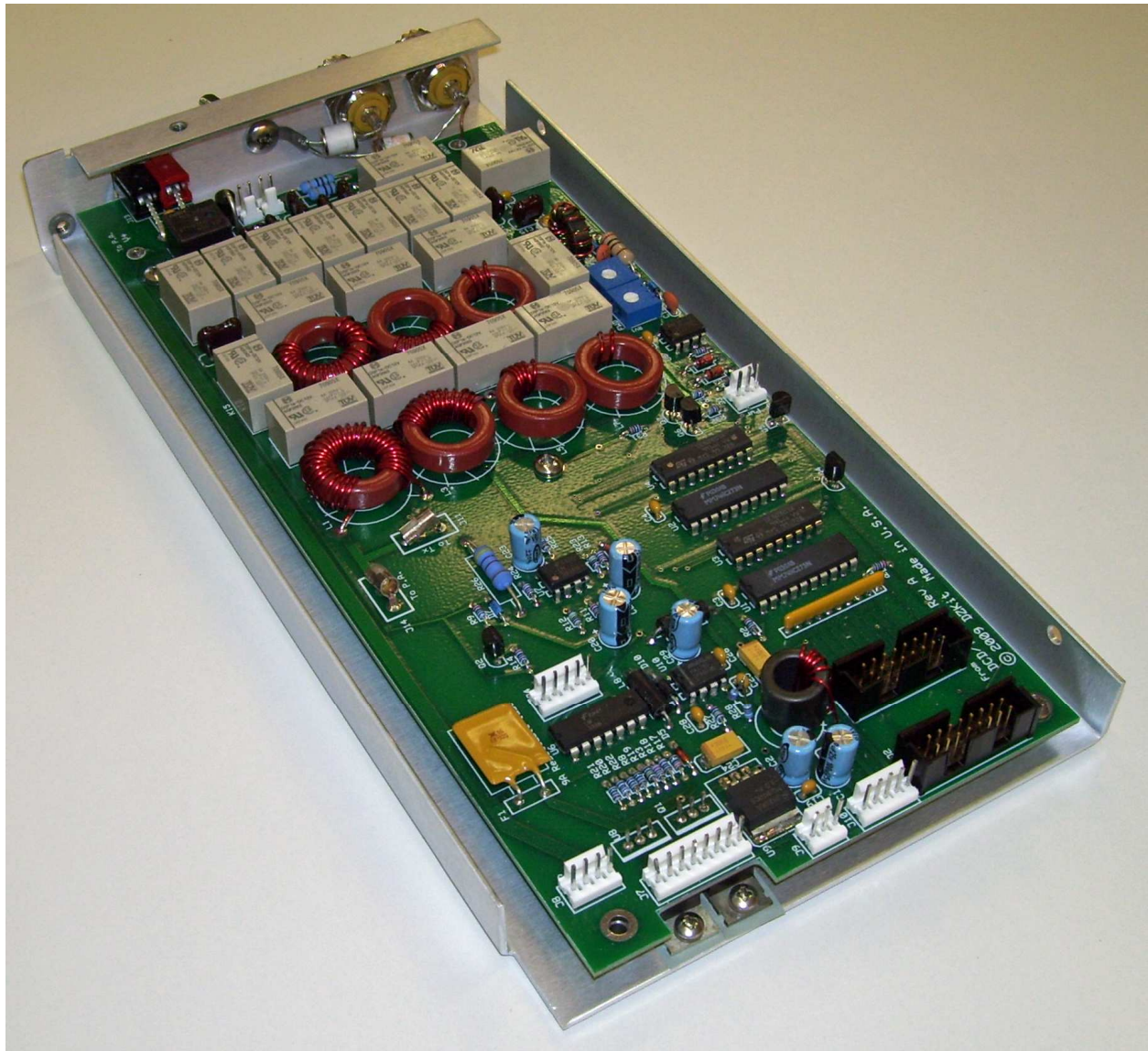

DCD Board, tuner and SWR meter installed, on tray



Appendix D1-Front Panel without controls

PARTS LIST

Item	Description	Qty
1	Screw - 6-32 x 1/4" PH Phillips M/S	6
2	Front Panel—no controls sheet metal	1
3	Front panel— no controls polycarbonate overlay	1
4	Controller Board	1

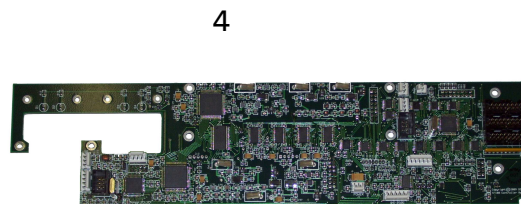
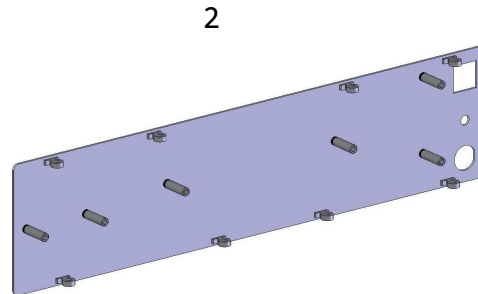



There are no assembly steps here. See the integration pages (pp 36-37) for front panel assembly for information regarding assembly of this module.



Appendix D2-Front Panel with controls

35

PARTS LIST—PC Board

Note: These parts comprise bag #1 for the front panel option

Item	Part	Description	Qty	Bag
1	C1, C2	.1uF monolithic capacitor	2	1
2	C3	100uF/25V axial leaded electrolytic capacitor	1	1
3	RV1,RV3, RV5-RV12	10K 9mm snap-in pot	10	1
4	J2,J4	8-pin 2-row male header	2	2
5	J3, J5	16-pin 2-row male header	2	2
6	RN1,RN2	1K - 5 isolated resistor network	2	1
7	R4	100 ohm 1/4W resistor	1	1
7	R1,R2	1K ohm 1/4W resistor	2	2
8	S1-S14	NKK Lighted Pushbutton	14	2
9	S16	Rotary Encoder/switch	1	1
10	S15	SP8T Rotary switch	1	1
11	RV2,RV4	Trimpot 10K top adjust	2	1
12		Blank board	1	-

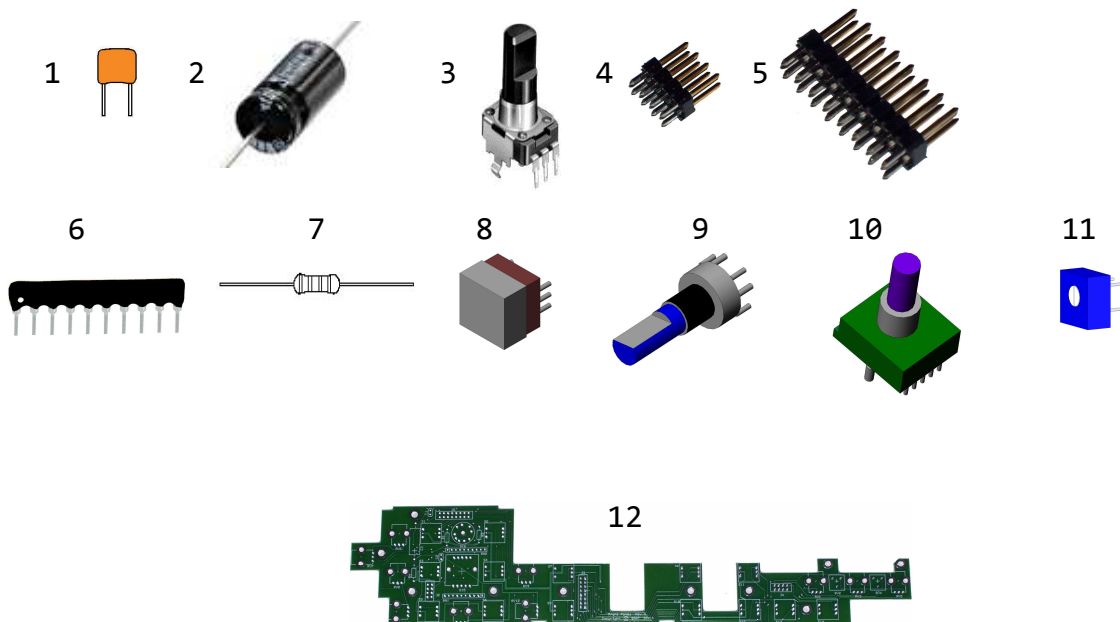



PARTS LIST—Hardware

Item	Part	Description	Qty	Bag
1		Knob-small	12	2
2		RIT Knob	1	2
3		Tuning knob	1	2
4		1/20" (.050") Hex key	1	4
4		1/16" (.063") Hex key	1	4
4		5/64" (.078") Hex Key	1	4
5		Screw - 6-32 x 1/4" PH Phillips M/S	14	4
6		Hole plug—.25" Nylon	2	4
7		Nut - 2-56	4	4
8		Hex M/F spacer - 6-32 x 7/16"	4	4
8		Hex M/F spacer - 6-32 x 1/2"	4	4
9		S-meter	1	4
9		Transmit meter	1	4
10		Rotary Pulse Generator (RPG)	2	3
11		Vacuum Fluorescent Display (VFD)	1	4
12		Front panel sheet metal	1	4
13		Front panel polycarbonate overlay	1	4
14	CA11	CA11—CONT-FPKEY cable	1	4
15	CA15	CA15—2-pin MTA to 2-pin MTA cable	1	4
16		White LED	4	3
17		Controller Board (assembled)	1	-

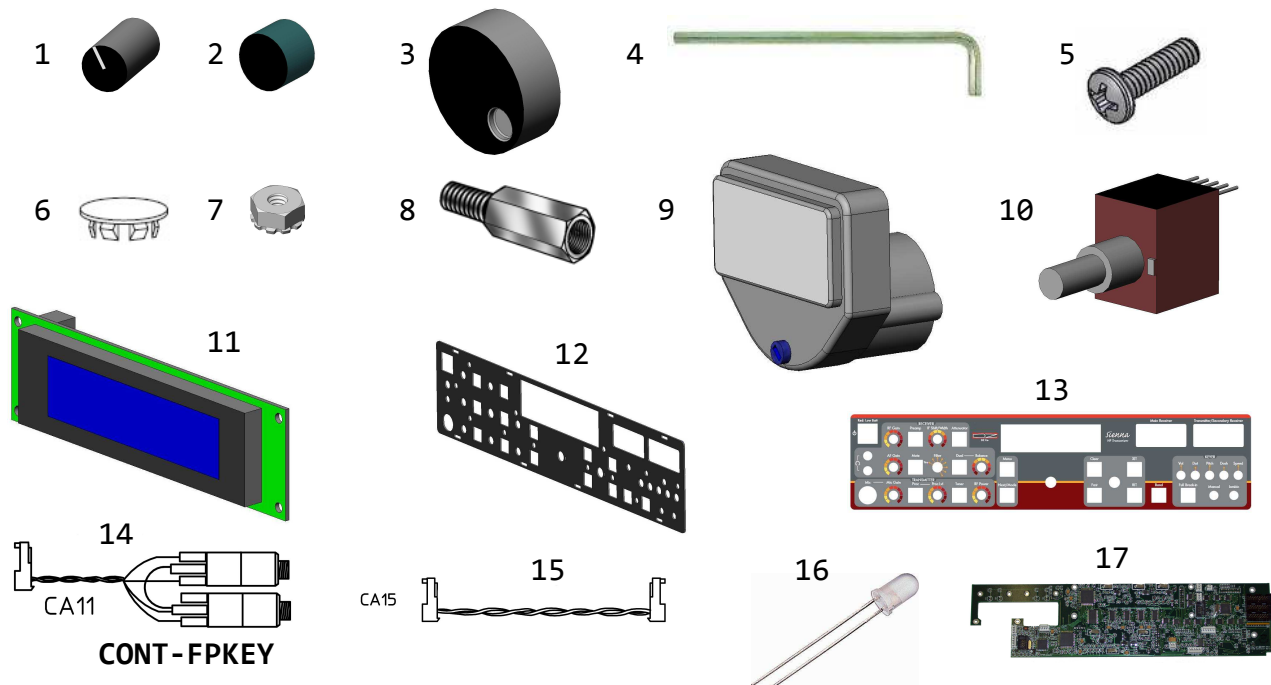



STEP-BY-STEP ASSEMBLY-Front Panel Board

- () Load and solder the two monolithic capacitors (Bag 1) at C1 and C2.
- () Load and solder the 100uF electrolytic capacitor C3 (Bag 1). The positive side has an indentation in the body and goes in the hole with the square pad.
- () Load and solder the two resistor networks (Bag 1). Although these are symmetric, so orientation does not matter, it is good practice to put the dotted side in pin 1, the square pad.
- () Load and solder the 100 ohm resistor (Bag 1).
- () Load and solder the two 1K ohm resistors (Bag 2) at R1 and R2.
- () Clip all leads done so far.
- () Load and solder all rotary pots (Bag 1). Make sure they lie flush on the board.
- () Load and solder the rotary encoder (Bag 1).
- () Load and solder the two trim-pots, RV2 and RV4 (Bag 1).
- () Bend the small tab on the 8-position rotary switch (Bag 1) 90 degrees. **Remove and save the Lockwasher and nut.** Load and solder the switch.
- () Mount all connectors (Bag 2) to the back of the board - the non-silkscreened side; i.e., solder them on the top side. Make sure they are flat against the bottom side of the board.
- () Insert the NKK pushbutton switches into the front panel board one at a time. (See note on next page.) Solder each one as it is installed before doing the next one. Be sure that the text on the back of the switch faces UP. There is a "+" symbol next to the middle pin on one side and a "-" symbol on the middle pin on the other side of the switch. The "+" side goes to the square pad. It is very important to get these right as the lights will not work if you get them reversed, and removing the switches is not trivial. **Tip: solder one pin while holding the board vertically, then lay it on a flat surface and heat that pin back up while you seat the switch on the board.** The plastic body must be absolutely flat and even. Be very careful not to touch the plastic switch covers with the soldering iron - they will melt.

This completes assembly of the Front Panel board. Keep the hardware bags for use in front panel integration.

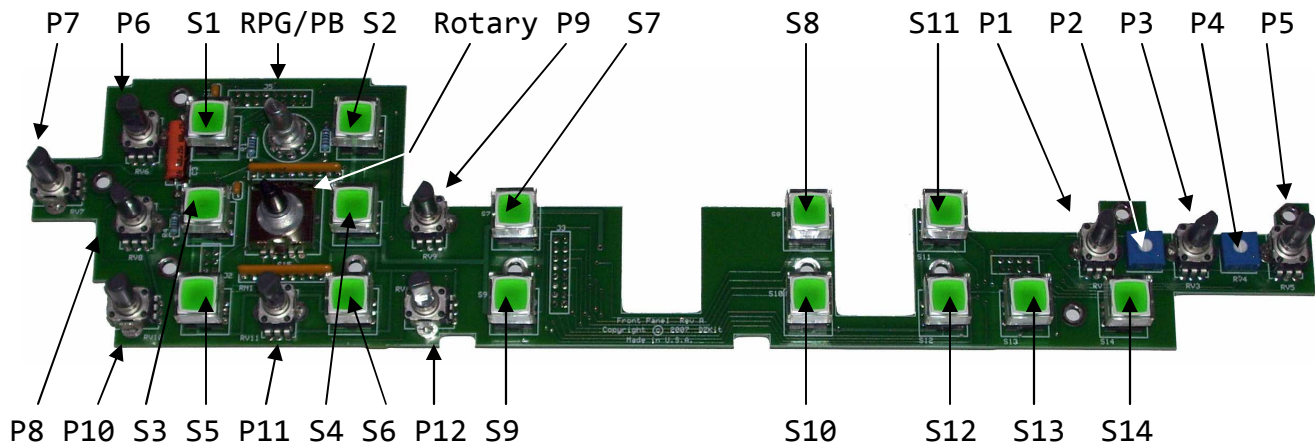

() Measure resistances to ground on connector pins as shown below. Values shown are +/-20%. Values of 0 can read 0 to 1 ohm. Use any mounting hole as a ground point. When a connector pin is shown as "Px", vary the corresponding potentiometer as shown above. Values will go from approx. 0 to approx 10K ohms*. When a pin is shown as "Sx", push and hold the corresponding switch. The reading should go from infinite (or high resistance) to approximately 0 ohms. The pushbutton in the RPG is called PB. If your volt/ohm meter has a "diode measurement" function, it should read 1.8V from "Power" to the noted LED pin (Lx). (Lx is the LED inside Sx.)

* Because the pots are not connected to power at this time, some will read from 0 to 2.5K and then go back down to about 550 ohms.

	L2	L1	L4	L3	P11	P9	P8	P7	
L9	S10	S2	S1	S4	S3	P10	PB	P6	P12
L12	S9								
L11	S8								
L10	S7								

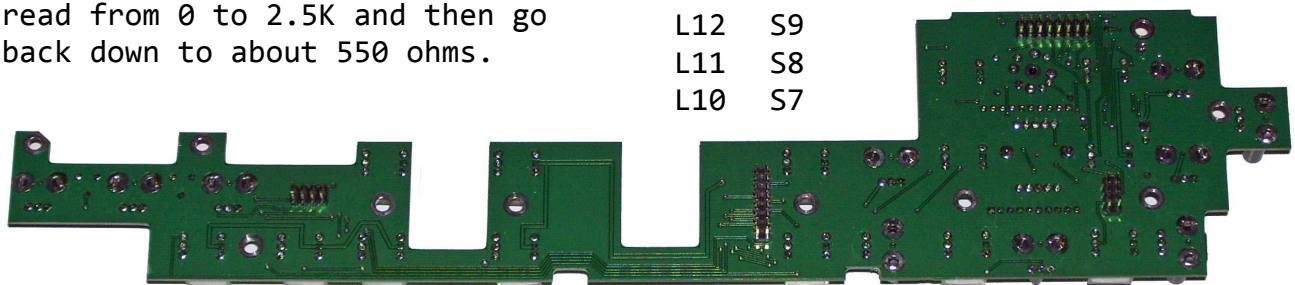

P5	P2	P4	2.5K
P1	10K	P3	0

L7	S14	LED Power	RPG
L8	S13	Rotary	RPG
L13	S12	L5	S5
L14	S11	L6	S6

Note: If you bought your front panel with specific LED colors and/or keycaps, be sure to look at the front panel polycarbonate panel and determine which ones you want where before soldering them in. Keycaps are fairly easy to interchange, but LEDs are not, since they are integral to the switch. If you bought a combination of colored LEDs, they will have been packed in separate bags. Be careful not to intermix them prior to assembly, because they are hard to tell apart.



Appendix E: IF Filter Board

PARTS LIST

Item	Ref Desig	Description	Qty	Stock Bin	Bag Nr
1	C30-47	10pF 50V ceramic disk NP0 5%	18	233	1
10	R18	68 ohm 1/4W 1%	1	433	1
1	C5 C6	27pF 50V ceramic disk NP0 5%	2	119	2
1	C3, C4 C7-29 C48-70	.1uF 50V ceramic disk Y5U 5%	48	8	2
2	C1, C2	10uF/25V aluminum electrolytic 20%	2	211	2
10	R21 R56-63	150 ohm 1/4W 1%	9	28	2

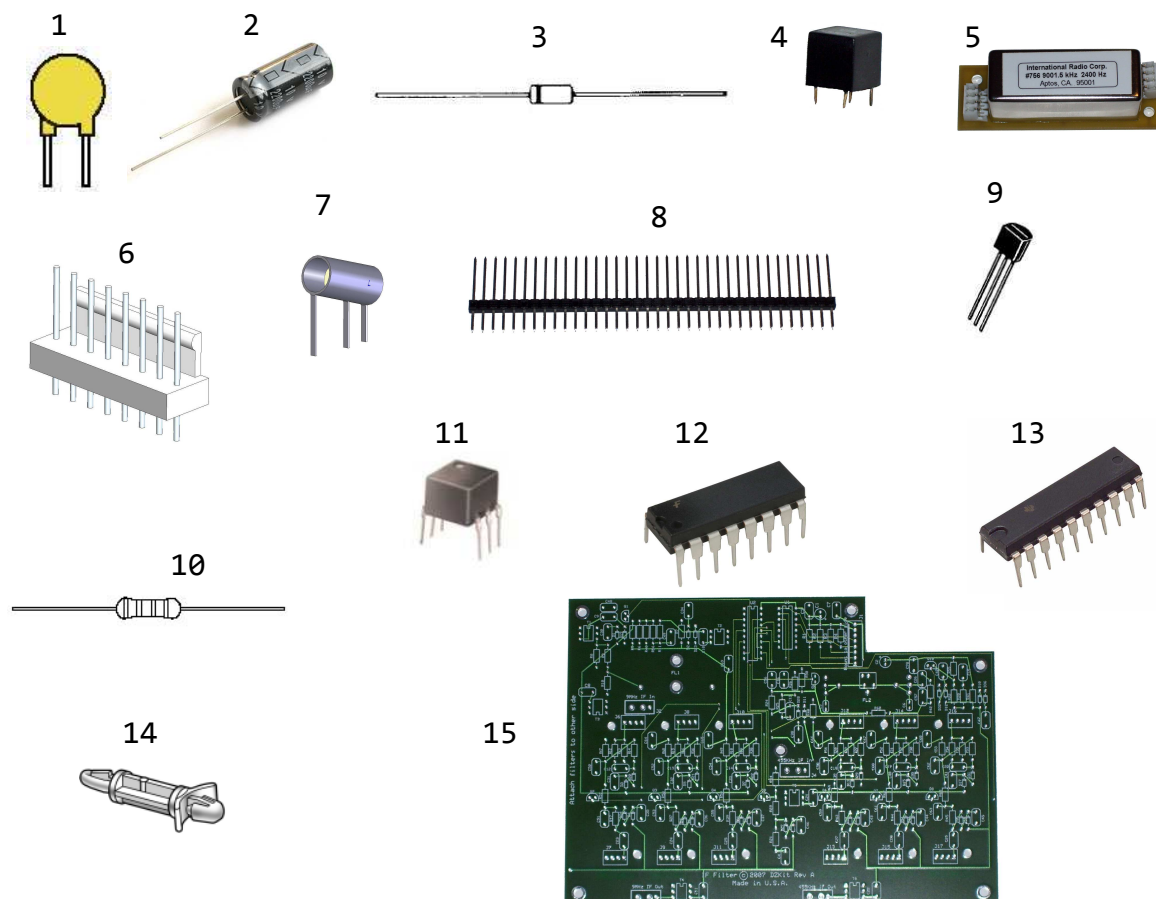



Item	Ref Desig	Description	Qty	Stock Bin	Bag Nr
3	D1-D36	1N914 signal diode	36	50	3
9	Q1-Q10	2N7000 MOSFET	10	227	3
10	R9, R12, R15	300 ohm 1/4W 1%	3	246	3
12	U1	74HC139 dual 2-4 decoder 16-pin DIP	1	312	3
13	U2	74HC240 octal buffer 20-pin DIP	1	401	3
4	FL2	LTM455DU ceramic filter	1	402	4
6	J1	8-pin .1" centers male keyed header	1	79	4
7	J2, J3, J4, J5 J18, J19	Taiko-Denki RF jack PCB-mt	6	407	4
8	Jx, Jy	36-pin 1-row male tall pins	2	397	4
10	R13, R16	470 ohm 1/4W 1%	2	44	4
14		Board lock 3/16" Nylon	12	107	4
10	R14,R25 R28, R31 R34, R36	620 ohm 1/4W 1%	6	42	5
10	R8, R10, R19	1.2K ohm 1/4W 1%	3	436	6
10	R5, R6, R7 R11, R17 R20, R23 R37, R38 R39	2.4K ohm 1/4W 1%	10	437	7
11	T5, T6	T36-1 36:1 transformer 6-pin DIP	2	364	7
10	R1-R4 R26, R29 R32, R35 R46-R55	10K ohm 1/4W 1%	18	17	8
11	T3, T4	T4-1 4:1 transformer 6-pin DIP	2	118	8
10	R22, R24 R27, R30 R33 R40-R45	20K ohm 1/4W 1%	11	248	9
11	T1, T2	T2-1T tapped 2:1 transformer 6-pin DIP	2	362	9
5	FL3	9.0015MHz 2.4KHz Inrad Crystal Filter	1	354	
15		Blank IF Filter Board	1	boards	



STEP-BY-STEP ASSEMBLY-IF Filter Board

IMPORTANT! ALL parts are mounted on the top (silkscreened) side of the board EXCEPT: J1, all filters and the connectors that are formed out of the 36-pin, single row connector.

Highlight or check off each part on the bag label as you install it on the board. Unless otherwise instructed, load all parts of the same type from each bag and clip the leads after soldering.

- () Load and solder all 1N914 diodes. Make sure that the side with a band on it goes into the hole with a square pad. Clip the leads as close to the board as possible (called "close-clipping"). Use silkscreened text and/or ExpressPCB to help you locate the parts.
 - () Load and solder all capacitors. Make sure the electrolytic capacitors are loaded with the long (+) lead in the holes with square pads and marked on the silkscreen with a '+'. Close-clip the leads. Use silkscreened text and/or ExpressPCB to help you locate the parts.
 - () Load all resistors. Use silkscreened text and/or ExpressPCB to help you locate the parts.
- Note: In the next three steps, you will load transformers. They look exactly the same but there are three different values. Be sure to load the one that is called out and double check before soldering!**
- () Load and solder transformers T1 and T2. These are marked T2-1T. Pin 6 (yes, pin 6) is marked with a dot. It must be loaded into the hole with the square pad.
 - () Load and solder transformers T3 and T4. These are marked T4-1.
 - () Load and solder transformers T5 and T6. These are marked T36-1.
 - () Load and solder IC's U1 and U2. Make sure that pin 1 goes in the hole with the square pad.
 - () Load and solder transistors Q1-Q10. Make sure the flat side of the transistor is lined up with the flat side of the silkscreened outline.
 - () Load and solder 6 Taiko-Denki RF connectors.
 - () Load connector J1 **on the bottom side of the board**. Make sure that the tab on the connector is on the side with

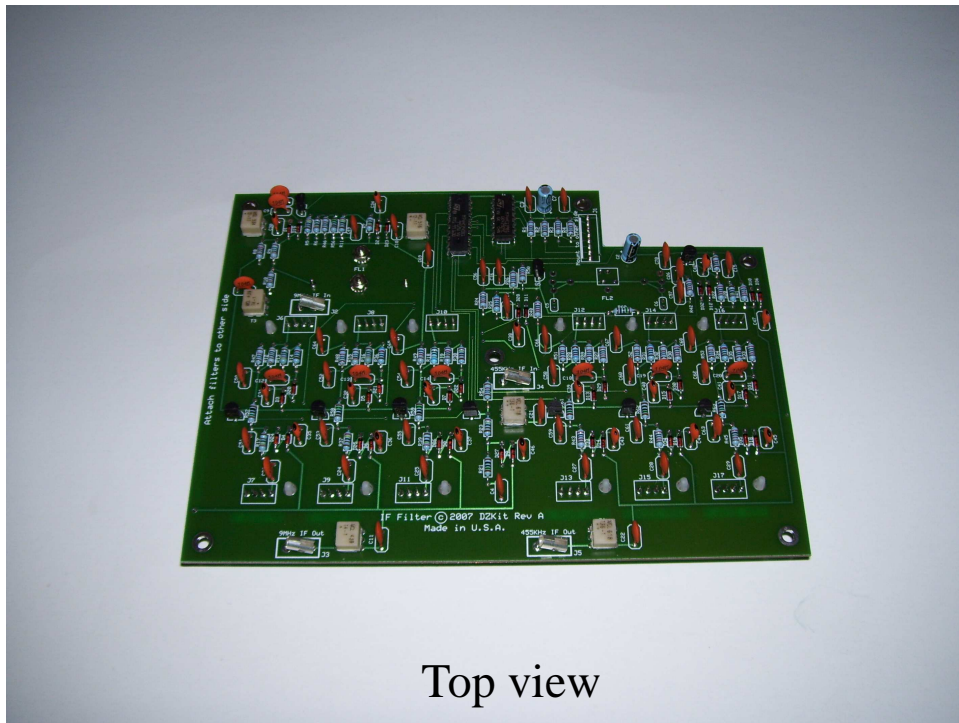

Top view

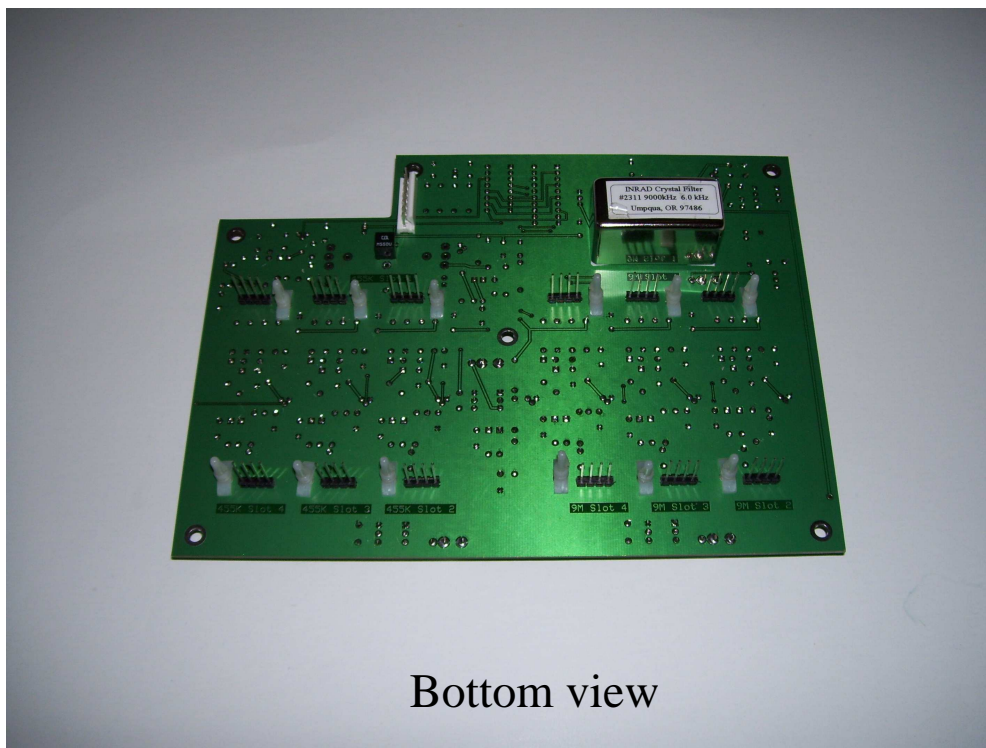

Bottom view

IF Filter Photographs



the heavy bar on the silk-screen.

- () If you have purchased a 5.8KHz Collins mechanical filter for 455KHz, install it on the bottom side of the board in the location marked FL2.
- () If you have NOT purchased the Collins filter, load and solder the LTM455DU 20KHz ceramic filter in FL2 on the bottom side of the board.
- () Cut the 36-pin connectors into 12 4-pin connectors. (There will be extra pins left over.) Use wire cutters on the indented sections of the plastic. These connectors are very sharp. Be careful! Solder all 12 **to the bottom side of the board**. Disregard the square pad. See detail E1.
- () If you have purchased the 9.0MHz 6KHz AM filter, remove it from its box and locate the plastic sheet. Cut the sheet 1/8" larger than the size of the filter. Carefully punch holes in the plastic sheet at the location of the threaded tabs and the two pins. Push the sheet onto the filter, shiny side toward the filter, and place the filter on the board at FL1 **on the bottom side of the board**. Attach the nuts and lockwashers to the top side of the board. Solder both pins. Clip the leads.
- () Push a Nylon fastener into each of the 12 holes located near the 12 4-pin connectors as shown in the bottom photo on page 89. Push the tabbed end into the board so that the tab compresses and lies flat against the board. You will hear a click as the tab locks into place.
- () After installation, you will add plug-in filters, including the 4-pole SSB filter that is included in this kit. Do not load it at this time, but set it aside in a secure place.
- () Measure the resistance to ground of each of the 8 pins on J1. Only pin 6 should read less than 1 ohm. All others should read a very high resistance (> 1 Megohm).

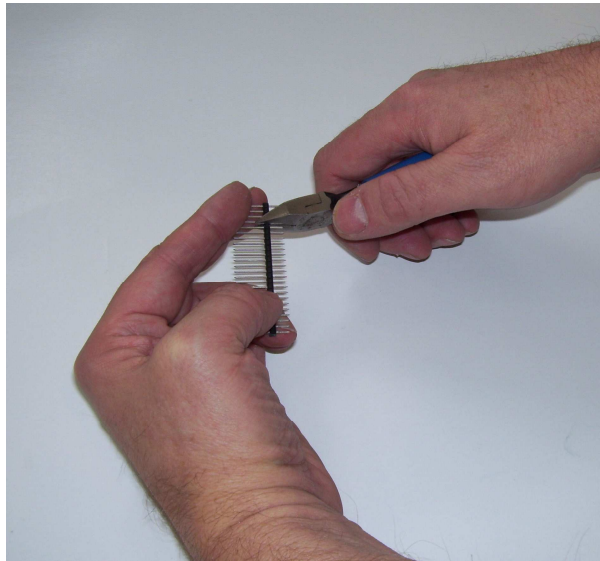

Detail E1. Cutting 36-pin connector into 12 4-pin connectors



Appendix F: RXBPF Board

Item	Ref Desig	Description	Qty	Stock Bin	Bag Nr
1	C45, C48, C50	10pF 50V monolithic C0G 5%	3	576A	1
3	D1, D2	1N914 signal diode	2	50	1
12	R12, R19, R30	4.75 ohm 1/8W 1%	3	356	1
1	C21	15pF 50V monolithic C0G 5%	1	576B	2
3	D3-D8	1N4007B 1000V rectifier	6	53	2
11	Q7, Q8	MPSH10 NPN RF transistor	2	54	2
12	R23-R29	27 ohm 1/8W 1%	7	356	2
1	C25	47pF 50V monolithic C0G 5%	1	576C	3
9	L7, L8	150nH 1210 10%	2	355A	3
12	R3, R5 R14, R21	51 ohm 1/8W 1%	4	356	3
1	C23	68pF 50V monolithic C0G 5%	1	576D	4
9	L5, L6	470nH 1210 10%	2	355A	4
12	R13, R20	100 ohm 1/8W 1%	2	356	4
1	C26	150pF 50V monolithic C0G 5%	1	576E	5
9	L2, L3	1.5uH 1210 5%	2	355A	5
12	R11, R18	470 ohm 1/8W 1%	2	356	5
1	C20	180pF 50V monolithic C0G 5%	1	576F	6
9	L1, L4	2.2uH 1210 5%	2	355A	6
12	R10, R17	680 ohm 1/8W 1%	2	356	6
1	C22, C24	220pF 50V monolithic X7R 10%	2	575B	7
12	R15, R22	1K ohm 1/8W 1%	2	356	7
1	C9, C10, C11	.0015uF 50V ceramic disk Y5P 10%	3	236	8
12	R9, R16	2.7K ohm 1/8W 1%	2	356	8

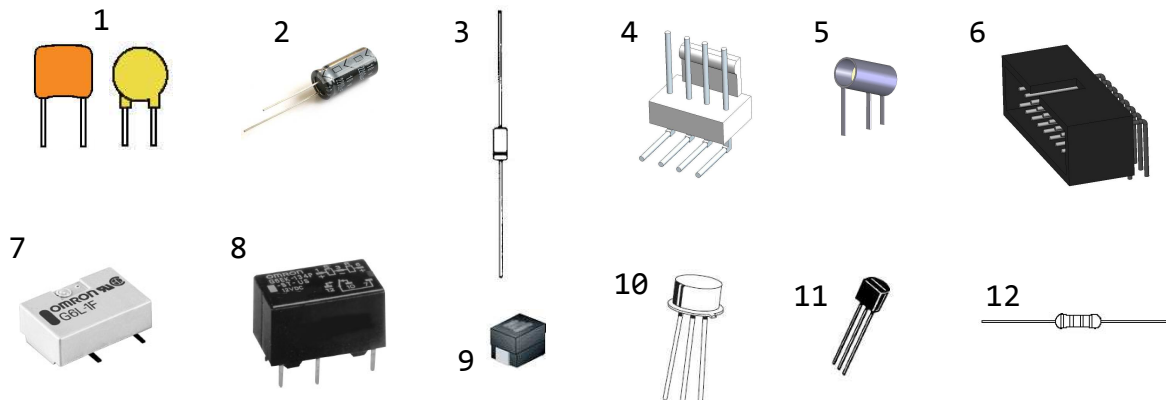



Item	Ref Desig	Description	Qty	Stock Bin	Bag Nr
1	C16, C32-C40 C43, C44, C47	.01uF 50V monolithic X7R 10%	13	575D	9
12	R7, R8	4.7K ohm 1/8W 1%	2	356	9
1	C30, C31	.047uF monolithic X7R 10%	2	576H	10
12	R1, R2	10K ohm 1/8W 1%	2	356	10
1	C3-C8 C12-C15 C17, C19 C28, C29 C41, C42 C46, C49	.1uF 50V monolithic X7R 10%	18	232	11
1	Ca-Ck	.1 uF 50V disk ceramic 10%	11	8	11
2	C1, C2	10uF/25V aluminum electrolytic 20%	2	211	11
12	R4, R6	78.7K ohm 1/8W 1%	2	356	11
4	J1	4-pin .1" centers male keyed header, right angle	1	373	12
5	J2, J3, J4	Taiko-Denki RF jack PCB-mt	3	407	12
6	J5	16-pin 2-row .1" centers r/a shrouded male header	1	379	12
7	K1, K2, K3	SPST 12V relay	3	150	12
8	K4, K5, K6	SPDT 12V relay	3	L1	12
13	RFC1	1mH inductor	1	19	12
14	RN1	Resistor network, .1" SIP 10-pin 10K	1	78	12
15	S1	DPDT Switch	1	517	12
16	T1, T2	FT37-43 toroid	2	59	12
		Magnet wire, green 24AWG (inches)	18	wire	12
		Magnet wire, red 24AWG (inches)	18	wire	12
10	Q3, Q4	2N5109 NPN RF transistor	2	45	13
11	Q1, Q2, Q5 Q6, Q9, Q10	2N7000 MOSFET	6	227	13





Item	Ref Desig	Description	Qty	Stock Bin	Bag Nr
17	U1	74HC138 3-to-8 decoder 16-pin DIP	1	494	13
17	U2, U3	74HC174 hex flip-flop 16-pin DIP	2	218	13
18	U4	74HC374 octal flip-flop 20-pin DIP	1	495	13
25	J17	4-pin .1" centers male keyed header	1	88	12
21		Filter pin socket	22	520	12
22		Hex M/F spacer - 4-40 x 3/16"	11	452	12
23		Nut - 4-40 KEPS nut	11	457	12
20		1-pin male tall pins	2	397B	12
24		Screw - 4-40 x 3/16" PH Phillips M/S	1	478	12
19		BPF Blank Board (not provided if options shown below were purchased)	1	761	12

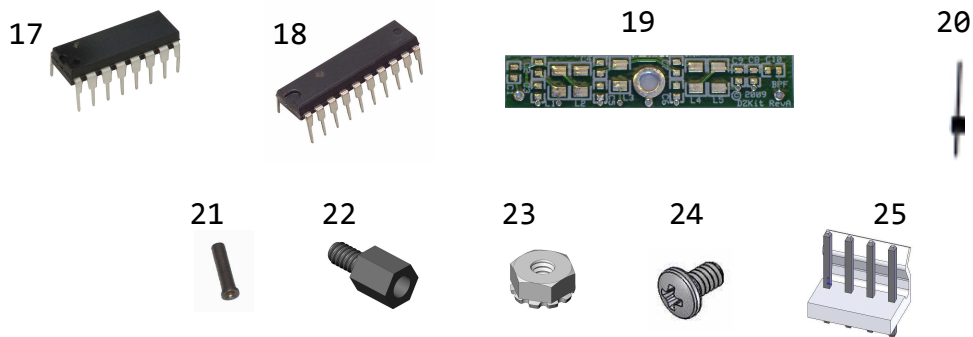

Appendix F1: BPF Board (Options 14-24, 114)

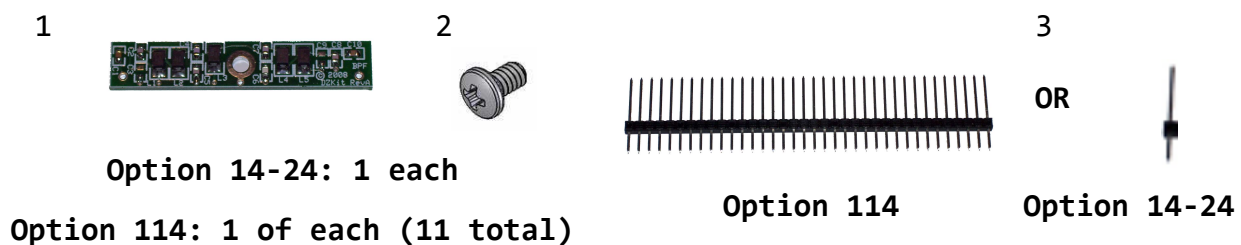

Item	Description	Qty	Stock Bin
1	Preloaded RxBPF board (11 types)	1	901-911
2	Screw - 4-40 x 3/16" PH Phillips M/S	1 or 11	478
3	36-pin 1-row male tall pins or two cut pins of the same type	1 or 2	397A or 397B



STEP-BY-STEP ASSEMBLY-RXBPF Board

Highlight or check off each part on the bag label as you install it on the board. Unless otherwise instructed, load all parts of the same type from each bag. Solder the pins after you have installed a couple of bags of parts and then clip their leads. You do not want to do too many parts at once because you may miss some, and with too many leads, they can interfere with each other. When clipping leads, note whether parts move, indicating that they have not been soldered, and apply solder.

- () Remove the RXBPF board carefully from its antistatic bag. Observe static control precautions while loading this partially-loaded board. The GaAsFET switches that have been loaded are very sensitive devices and will have a direct effect on receiver performance if they are damaged. Be careful!
- () Locate the 11 0.1uF disk ceramic capacitors. Solder one between the pads on each end of the rectangular “slots” labeled RX1-RX11. *Do this ONLY on slots for which you do NOT plan to install bandpass filters (BPFs).*
- () Load and solder all other capacitors. Make sure the two electrolytic capacitors are loaded with the long (+) leads in the holes with square pads and marked on the silkscreen with a ‘+’. Use silkscreened text and/or ExpressPCB to help you locate the parts. Note that all capacitor bags also contain resistors. Do not load the resistors until the next step.
- () Load all resistors. Use silkscreened text and/or ExpressPCB to help you locate the parts. Note that some resistors are in the bag with diodes, and the rest are in the capacitor bags.
- () Load and solder coil RFC1 (bag 12).
- () Load and solder all diodes. Make sure that the side with a band on it goes into the hole with a square pad. *Note: Rev A boards require diodes D1 and D2 to be soldered back-to-back (bands facing opposite directions) on top of coil RFC1 instead of in the places marked D1 and D2.*
- () Load all inductors. These are surface mount parts. To load a part, apply a small amount of solder to one of the pads on the board, then place the part on the pads and hold it in place with an awl, screwdriver or other small tool while applying heat to the



same pad. When one side is soldered, solder the other side. Note that there are also transistors and/or ICs in the same bags. Save them for the next steps.

- () Load and solder the two metal transistors, Q3 and Q4. These transistors will only go in one way, and the tab on the side should be lined up with the silkscreened tab on the board. Insert the parts all the way down on the board.
- () Load and solder Q7 and Q8. Be sure to line up the flat side with the silkscreened outline on the board. Wiggle one pin into the hole, then twist the part gently until the other two pins can be inserted. Push the transistors down such that the bottom of the plastic body is about .1" off the board.
- () Load and solder the remaining six plastic transistors in the same manner as the previous step.
- () Load and solder the resistor network, RN1. Be sure that pin 1, marked by a dot, goes into the hole with the square pad.
- () Load and solder RFC1.
- () Load and solder switch S1. Make sure that the switch lever extends out the side of the board.
- () Load relays K1-K3. These are surface mount relays. To load a part, apply a small amount of solder to one of the pads, then place the part on the pads (being careful to note the orientation) and hold it in place with a finger while applying heat to the same pad. When that pin is soldered and the relay is positioned inside the silkscreened outline, solder the other pins.
- () Load and solder relays K4-K6. These will only go in one way.
- () Cut the red magnet wire into two equal pieces, 9" each.
- () Cut the green magnet wire into two equal pieces, 9" each.
- () Twist one red and one green wire together, about 2 turns per inch. Do the same with the other pair of wires.
- () Wind 5 turns of one twisted pair of magnet wire evenly around one of the two FT37-43 toroids (bag 12), spreading the windings out so that most of the core is covered. Remember that each pass of the wire through the toroid counts as one turn. See photo.
- () Repeat the above step using





the other FT37-43 toroid. See photo.

- () For each toroid, insert the red wires into the holes marked 1 and 2, and the green wires into the holes marked 3 and 4. (Run the green wires outside the toroid to get them to reach to the holes.) Cut excess wire, remove the toroids and carefully strip (or melt) the coating off of the last 1/4". Re-insert the toroids and solder the leads.
- () Using an ohmmeter, Verify that there is continuity from pin 1 to pin 2, and pin 3 to pin 4, on each part. If not, apply more heat and re-measure.
- () Load all ICs. Before inserting each one into the board, verify that the name of the part that's printed on the IC matches the name on the bag label (e.g., 74HC138 - ignore other prefixes and suffixes). Do not solder them yet! Be sure that pin 1 of each IC is loaded in the square pad. Note that U1 is a 16-pin part as are U2 and U3. Be sure not to load U1 in the holes for U2 or U3, and vice versa. To keep the ICs in place before soldering, bend the corner pins over on the bottom side of the board.
- () Double check that no IC pins are bent under the parts, the right ICs are loaded in the right places and that pin 1

is on the square pad. When you are absolutely certain that the ICs are correctly loaded, solder all pins.

- () Load all connectors. *J1, the 4-pin right-angle connector, mounts on the BOTTOM side of the board. ALL others mount on the top.*
- () Attach 11 4-40 x 3/16" hex male/female standoffs in the center holes of the 11 filters (marked RX1-RX11). Use 4-40 KEPS nuts on the bottom of the board to secure them.
- () If you purchased Option 114 (RFSET), it is provided with a single 36-pin male header. Cut this part into 22 single-pin connectors and discard the rest. If you purchased individual filters, each one is provided with two pins of the same type.

For each filter that you purchased, there is a corresponding "slot" on the RXBPF board. Use the following procedure to install boards. Skip the following six steps if you did not purchase any filters.

- () Push a filter pin socket onto each long pin.
- () Insert two pin/socket combinations in the holes for the first filter you purchased.
- () Place the appropriate BPF board onto the pins and push it down until it meets the

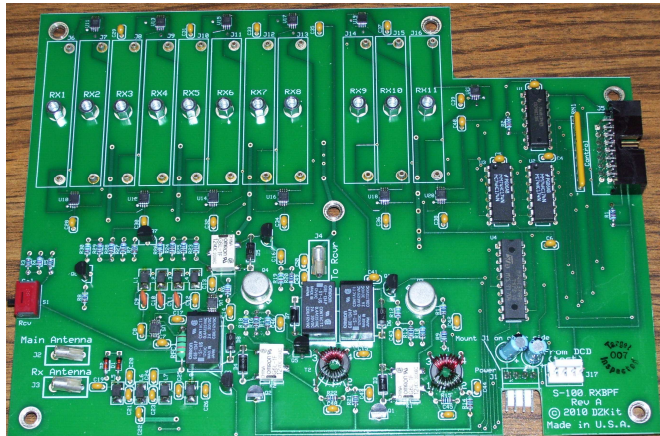

RXBPF board after loading, prior to insertion of BPF's

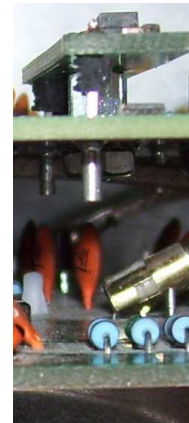

Edge view of BPF after installation

Cut to 1/4"

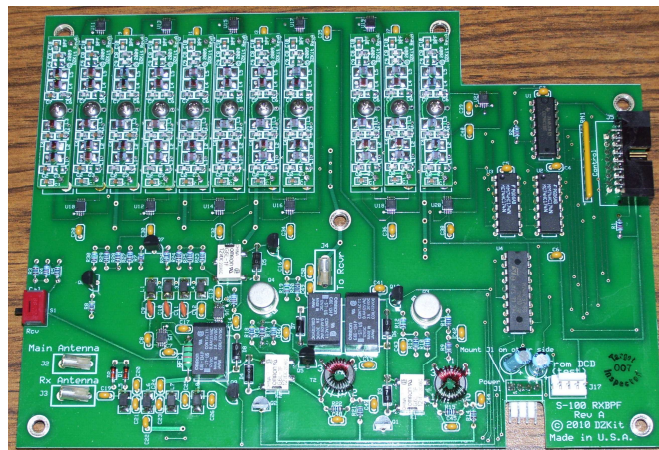
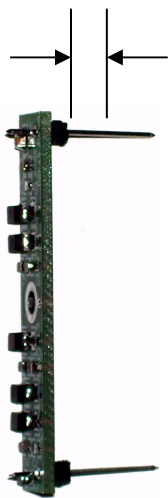

RXBPF board after loading and insertion of BPF's

- hex standoff. Tighten the board using a 4-40 x 3/16" screw.
- () Pull on a socket while pushing the black body of each pin up against the BPF board.
- () Turn the RxBPF board over and solder the pin sockets to the bottom of the board.
- () Solder the pins to the BPF board. Clip excess lead length.
- () Check your work carefully for solder bridges, shorted traces and backwards or missing components.
- () Measure the resistance of each of the 4 pins on J17:
 - J17 pin 1: > 200 ohms
 - J17 pin 2: (open)
 - J17 pin 3: < 1 ohm (ground)
 - J17 pin 4: > 1 Megohm

This completes assembly of the RXBPF board.



Appendix G: Receiver Board

PARTS LIST

Item	Ref Desig	Description	Qty	Bag Nr
1	C73 C76 C90 C123 C124 C125 C136 C137 C138 C158	6-70pF trimmer	10	1
2	C4 C17 C24 C25 C26 C27 C93 C94 C106 C110	22uF/16V bi-polar aluminum electrolytic 20%	10	1
3	C1 C132 C170	100uF/25V 20% aluminum electrolytic	3	1
3	C60 C97	330uF/16V 20% aluminum electrolytic	2	1
3	C103 C104	470uF/10V 20% aluminum electrolytic	2	1

1



2



3





Item	Ref Desig	Description	Qty	Bag Nr
4	D1 D2 D3 D4 D5 D6 D7 D10 D13 D15	1N5711 Schottky diode	10	2
4	D8 D9 D11 D12 D16 D17 D18 D19 D20 D21	1N914 signal diode	10	2
5	FL2 FL3 FL4	LTM455DU ceramic filter	3	3
6	J3	16-pin 2-row .1" centers r/a shrouded male header	1	3
7	J4 J19 J22 J25	2-pin .1" centers male keyed header	4	3
8	J6 J12 J16 J20 J21 J23	3-pin .1" centers male keyed header	6	3
9	J5 J13 J24	4-pin .1" centers male keyed header	3	3
10	J10	8-pin .1" centers male keyed header	1	3

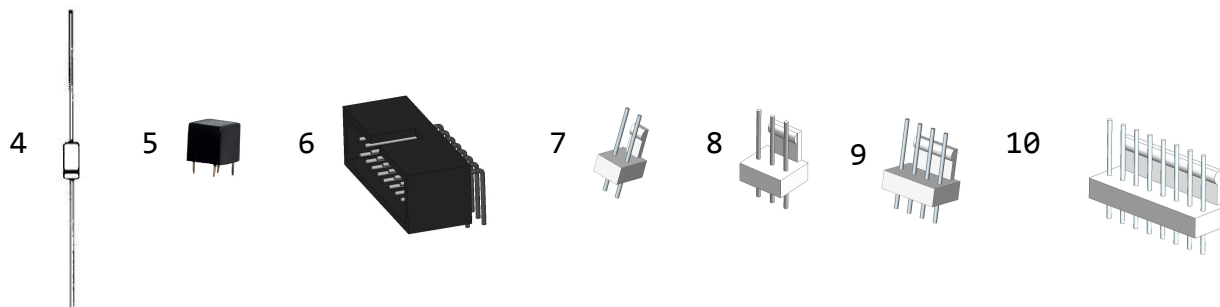



Item	Ref Desig	Description	Qty	Bag Nr
11	J18 J27 JP4	3-pin .1" centers header	3	3
12	JP1 JP2 JP3	2-pin .1" centers header	3	3
13	JPx	2-pin female shorting bar	3	3
14	J1 J2 J7 J8 J9 J11 J14 J15 J17 J26	Taiko-Denki RF jack	10	3
15	L1 T3	FT50-61 toroid	2	3
		Magnet wire, red 24AWG (inches)	20	3
		Magnet wire, green 24AWG (inches)	10	3
16	L5 L9	100uH variable inductor	2	3
17	RN1	Resistor network, .1" SIP, 10-pin 10K	1	3
18	T2	T4-1 4:1 transformer 6-pin DIP	1	3
19	RV1	10K trimpot	1	3
19	RV2	500 ohm trimpot	1	4
18	T1 T4 T5 T6 T7	T36-1 36:1 transformer 6-pin DIP	5	4
20	U18 U19	LM380 audio amplifier 14-pin DIP	2	5
21	U9 U12 U32	MC1350 IF amplifier 8-pin DIP	3	5
22	U6 U8	TUF-3 Mixer	2	5
23	U31	LM2940CS-9 9V regulator TO-263	1	5
24		Preloaded Rx Board	1	6
25	FL1	Inrad 70.455MHz filter (Option 206)	1	

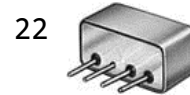
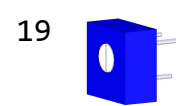
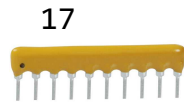
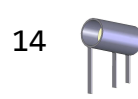
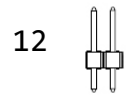
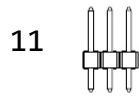

24

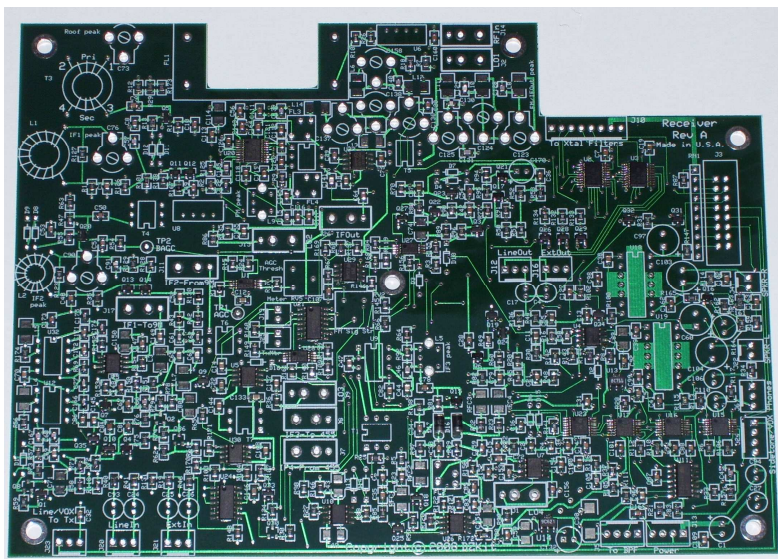

25





STEP-BY-STEP ASSEMBLY-Receiver Board

There are a lot of parts on this board. It can take quite a while for you to locate the parts visually. We highly recommend that you use the free ExpressPCB software to help you find the parts. Load the file receiver_revx_no_traces.pcb (the x represents a revision letter).

Highlight or check off each part on the parts list that is inside the bag as you install it on the board. If parts have long leads, solder the leads after you have installed about 5-10 of them and then clip their leads. You do not want to do too many parts at once because you may miss some, and with too many leads, they can interfere with each other. When clipping leads, note whether parts move, indicating that they have not been soldered well, and re-solder them.

Hint: Some parts fit loosely in the pads. To solder them, hold the board upright and use one finger to hold the part in place while you solder one lead on the bottom. It doesn't matter if the part is not flush. Once you've "tacked" it in, push it flat while reheating the pin, then lay the board upside down and solder the remaining leads. Note – this works well on multi-pin connectors, but you can burn your

finger if you are touching the lead you are tacking down. Be sure to touch other pins or the connector body instead of the lead you are soldering!

- () Remove the Receiver board from its antistatic bag. Handle this board with care and observe anti-static precautions to avoid damaging the pre-loaded parts.
- () Load and solder all 70pF trimmer capacitors (Bag 1).
- () Load and solder all 22uF/16V aluminum electrolytic capacitors (Bag 1) flush with the board. These parts are bipolar – they can be installed in either direction even though one lead is longer.
- () Load and solder the two 470uF/10V electrolytic capacitors and three 100uF/25V aluminum electrolytic capacitors (Bag 1) flush with the board. Be sure to put the longer ('+') lead in the square pad, also marked with a '+' symbol. (The caps are very close together, and the '+' symbol can be interpreted as belonging to the wrong part, so be sure to look at the square pad!)
- () Load and solder the two 330uF/16V electrolytic capacitors (Bag 1).



- () Load U31 (Bag 5), a 9V regulator, on the bottom of the board. This is an SMT device. To load, place the part on the pads and solder one pin while holding the device in place. Then solder the other two pins. Apply solder to the tab along the top edge and keep the heat on until the solder flows freely around the tab. On the top side, apply solder to the two holes that are located in the center of the tab area.
- () Load and solder all 1N914 diodes (Bag 2). Be sure that the side with a band goes into the hole with a square pad. These parts are colored red.
- () Load and solder all 1N5711 diodes (Bag 2). Be sure that the side with a band goes into the hole with a square pad. These parts are colored blue.
- () Load and solder FL2, FL3 and FL4 (Bag 3), 20KHz ceramic filters.
- () Load and solder L5 and L9 (Bag 3), the two variable inductors.
- () Load and solder resistor network RN1 (Bag 3). Be sure that the dot marking pin 1 goes into the hole with the square pad.
- () Load and solder trimpot RV1 (Bag 3). The value of this pot is marked on the side with a "103" (10K ohms).
- () Load and solder trimpot RV2 (Bag 4). The value of this pot is marked on the side with a "501" (500 ohms).
- () Load and solder T2, a Minicircuits T4-1 transformer (Bag 3). Pin 6 is marked by a dot. This pin goes in the hole with the square pad. *The other 6-pin transformers look exactly like this one. Make sure you load the T4-1 transformer into T2.*
- () Load and solder five T36-1 Minicircuits transformers (Bag 4). Pin 6 is marked by a dot. This pin goes in the hole with the square pad.
- () Load and solder U6 & U8, TUF-3 RF mixers (Bag 5). Make sure the body is oriented so that it does not extend beyond the silkscreened outline. Leave a small gap (less than 1/32"/0.8mm) between the bottom of the part and the board to avoid shorts between the pads and the case.
- () Load and solder the two LM380 (NTE740) audio amplifier ICs, U18 and U19 (Bag 5). Be sure



that pin 1 goes into the hole with the square pad.

- () Load and solder U9, U12, and U32 (Bag 5), the MC1350 (NTE746) IF amplifier ICs. Be sure that pin 1 goes into the hole with the square pad.
- () Locate the two toroids and magnet wire (Bag 3). Cut a 3" length of red magnet wire and wind one toroid with 2 turns. Leave about 1/2" of lead extending out from the toroid. Load it into L1. Each time the wire passes through the center is considered 1 turn. Leave about 1/2" of lead extending out from the toroid. Solder the leads, keeping the soldering iron (set to 750 degrees F) on the leads until the coating melts away and the solder flows onto both the pad and the wire smoothly. This can take about one minute per lead. You may prefer to note the location where the wires touch the pads, then remove the toroids, tin the wires, then re-insert them and solder them in place.
- () Cut a 10" length of red magnet wire. Wind 13 turns completely around the remaining toroid. Then cut a 3" length of green magnet wire and wind 3 turns on top of the side of the toroid that does not have leads extending out from it. Solder the four leads at T3. The side with 3 turns goes into the holes marked Primary (pins 1 and 2).
- () Clip excess leads from the toroid wires.
- () Using an ohmmeter, verify that there is continuity (<1 ohm) from pins 1 to 2 and from 3 to 4 on T3, and from one lead to the other on inductor L1. If not, apply more heat to the leads and re-measure.
- () Load and solder J18, J27 and JP4 (Bag 3), 3-pin headers. Orientation does not matter. Place a shorting bar between the center pin and the pin labeled "sql dac".
- () Load and solder JP1, JP2 and JP3 (Bag 3), 2-pin headers. Place a shorting bar on JP1. Place the remaining shorting bar *on only one pin* of JP2 or JP3.
- () Load and solder all white AMP MTA connectors. Be sure the tab lines up with the heavy line on the silkscreened outline. Load these connectors one at a time. See the soldering hint at the beginning of this section.
- () Load and solder J3, a right-angle 16-pin ribbon cable connector. Pin 1 on this connector is marked with an embossed triangle. Be sure this pin goes into the hole with the square pad.
- () Load and solder the 10 RF connectors. Bend the small lead down, then squeeze the



thicker leads together slightly so the connector will not fall out while you solder it. Solder one lead, then push the connector down so that the end with the small pin is flush with the board. These connectors point up at a 45 degree angle.

- () If you did *not* purchase the optional Inrad roofing filter:
 - () Locate Bag 7. Insert a 3-pin insulating wafer on the 3-pin crystal filter and solder the filter to the Filter board.
 - () Load and solder the two T36-1 transformers. The lead with a dot next to it goes into the square pad. Note: The two transformers mount in opposite directions! Be careful!
 - () Locate the long pins that you earlier clipped apart when building the RxBPF board. Cut one into four one-pin connectors. Insert the short end into the four holes at FL1 and solder them so the pins point straight up. These pins are very sharp. Be careful!
 - () Insert the IF Filter

board onto the 4 pins such that the text reads upside down compared to text on the Receiver board. Solder the pins and clip excess lengths.

- () If you purchased the optional Inrad roofing filter:
 - () Cut two 1/4" squares of plastic sheet and puncture the center with an awl, or small knife or screwdriver. Place the squares over the two ungrounded pins of the 70.455MHz roofing filter. The ungrounded pins are the two that are not directly connected to the metal body. Load and solder the filter as shown, with the printing on top upside down compared to the other text on the board.
 - () Check your work carefully. Make sure all polarized parts are inserted correctly, that pin 1 of the ICs and resistor network are on the square pads, and that all parts are soldered. Also check to be sure that all leads are clipped and not shorting other leads.

This completes assembly of the Receiver board.

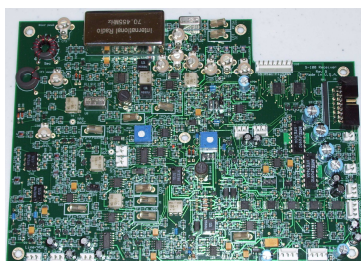

Completed receiver board. Note the orientation of the optional roofing filter.



Appendix H: Transmitter Board

PARTS LIST: PC Board

Item	Part	Description	Qty	Bag
1	C108	18pF silver mica (sm)	1	1
1	C86	20pF sm	1	1
1	C103	27pF sm	1	1
1	C112	33pF sm	1	1
1	C110	47pF sm	1	1
1	C105	56pF sm	1	1
1	C95, C107	68pF sm	2	1
1	C85	82pF sm	1	1
1	C40, C89	100pF sm	2	1
1	C106	120pF sm	1	1
1	C101, C109, C111	150pF sm	3	1
1	C36	220pF sm	1	1
1	C49, C55, C104	270pF sm	3	1
1	C13, C39, C56, C87, C90, C91	330pF sm	6	1
1	C38, C88	390pF sm	2	1
1	C59, C99	560pF sm	2	1
1	C11	1000pF sm	1	1
1	C34, C41	1200pF sm	1	1
1	C37	2200pF sm	1	1
2	C84, C121, C122	22uF/16V bi-polar aluminum electrolytic	3	1
3	C2, C30, C82, C96	10uF/25V aluminum electrolytic	4	1
4	C1, C47, C63, C116, C127	100uF/25V aluminum electrolytic	5	2
5	D12, D13	1N914 signal diode (red)	2	2
5	D3, D4, D5, D11, D17	1N4007B rectifier diode (black)	5	2
5	D1, D2, D6, D15	1N5711 Schottky diode (blue)	4	2
6	F1	250mA axial picofuse	1	2

1

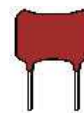

2



3



4



5

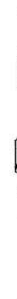

6





Item	Part	Description	Qty	Bag
7	J1	16-pin 2-row .1" centers shrouded male header	1	3
8	J3, J4, J15	2-pin AMP MTA male keyed header	3	3
9	J6, J18	3-pin AMP MTA male keyed header	2	3
10	J14	4-pin AMP MTA male keyed header	1	3
11	J5	5-pin AMP MTA male keyed header	1	3
12	J13, J17	4-pin 2-row female bd mt socket	2	3
13	J12, J16	8-pin 2-row female bd mt socket	2	3
14	J2	8-pin DIN PC-mt	1	3
15	J8, J9, J10, J11	RF Jack	4	3
16	J7	Triple phono connector	1	3
17	K1-K10	SPST 12V SMT relay	10	3
18	JP1-7, 9-12	2-pin jumper header	11	3
19	JP8	3-pin jumper header	1	3
20	JS1-12	2-pin jumper shorting bar	12	3
21	K12, K13	SPDT 12V relay	2	3
22		Hex M/F spacer - 4-40 x 3/16"	4	3
23		Thermalsil sticky-back insulator	4	3
24		Screw - 4-40 x 3/16" PH Phillips M/S	10	3
25		Fiber shoulder washer	4	3

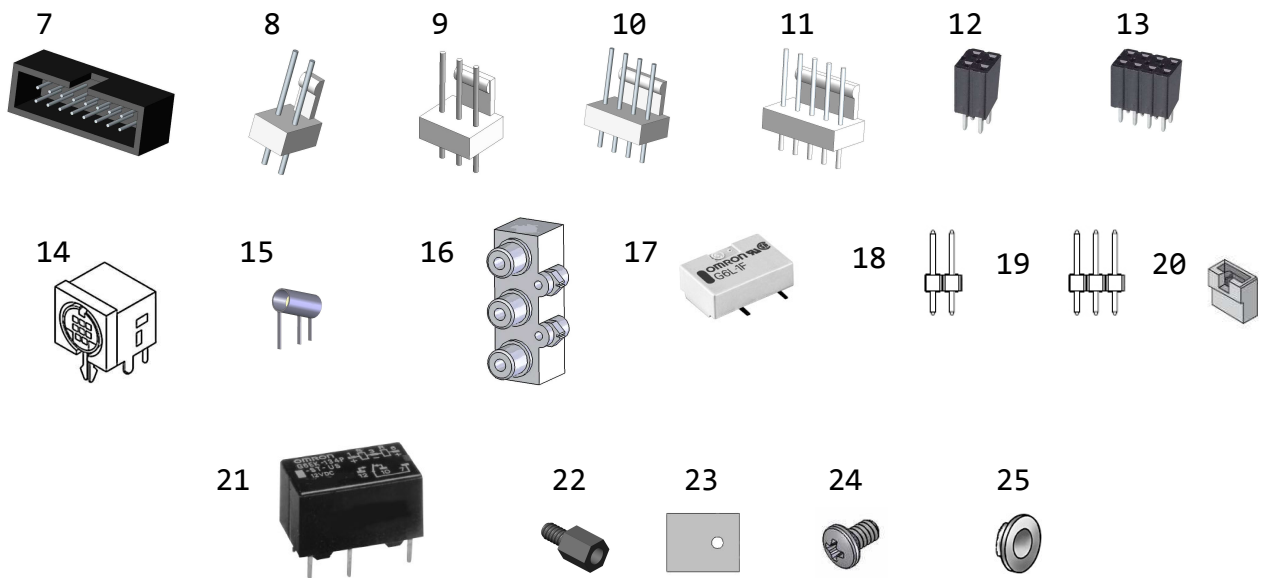



Item	Part	Description	Qty	Bag
26	L1-L4	T50-2 toroid (red)	4	4
27	L5-L12	T50-10 toroid (black)	8	4
28	L13, L14	Ferrite Bead	4	4
		RG-178/U coaxial cable (inches)	8	4
		#24 red magnet wire (inches)	180"	4
		#24 green magnet wire (inches)	36"	4
5	D7-10, 14	1N5231B 5.1V Zener diode	5	5
29	Q14	2N5109 NPN low-noise RF transistor	1	5
30	Q11	Power N-channel MOSFET (SMT)	1	5
31	Q4, Q5	2SC1969 NPN RF power transistor	2	5
32	R73	.05 ohm 2W sense resistor (SMT)	1	5
33	R27	47 ohm 1W power resistor	1	5
34	R56	1.5 ohm 1W power resistor (SMT)	1	6
35	R39	180 ohm 1W axial power resistor	1	6
5	D16	1N5239B 9.1V Zener diode	1	6
31	Q3	2SC2166C NPN RF power transistor	1	6
36	T2	T36-1 6-pin transformer	2	6
31	Q13	TIP31A NPN power transistor	1	7
34	R85	50 ohm 1W power resistor (SMT)	1	7
37	RN1	Resistor network, 10-pin 10K ohm	1	7
38	RV1	1M trimpot - horizontal	1	7
39	T1, T3	FT37-43 toroid	2	7
40	T5	Binocular core	1	7
41	T4	FT50-43	1	7
36	T6	T4-1 4:1 transformer 6-pin DIP	1	7
42	TH1	Thermistor - 10K ohm	1	7
43	U10	TUF-3 RF mixer	1	7
44	Y1-Y19	10.73MHz Crystal	19	8
44		Mylar crystal insulator—HC-49/U	19	8
45		Mylar crystal insulator—HC-49/U-3pin	2	8
46	FL1, FL2	10.7MHz 4-pole, 12kHz filter	2	8
		#24 bare wire (inches)	15	8
47		Heatsink - 2.5" x 4.5", black anodized	1	-
48		Partially loaded Transmitter Board	1	-

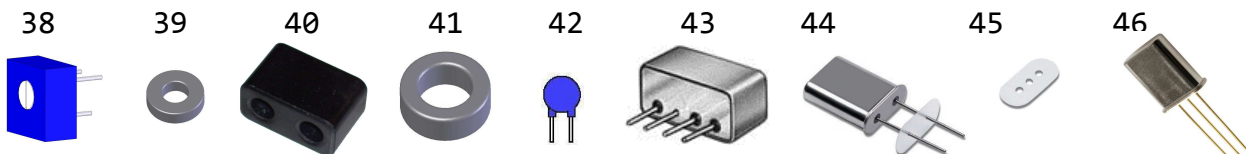
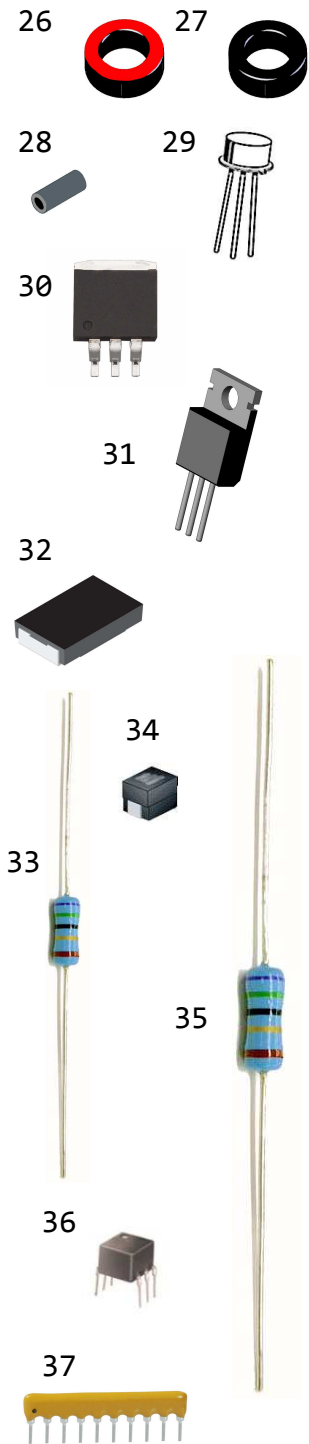



PARTS LIST: Mounting Hardware

Item	Description	Qty	Bag
	SWR Meter Kit (parts added to DCD board—see App. C2)	1	-
	TXBPF Kit (see Appendix I)	1	-
49	Screw - 4-40 x 3/8" PH Phillips M/S	1	HW
50	Screw - 2-56 x 5/8" PH Phillips M/S	2	HW
51	Nut—4/40 KEPS nut	1	HW
52	Nut - 2-56	2	HW
53	Hex F/F spacer, 4-40 x 1 1/4"	1	HW
54	Lockwasher - #2	2	HW
55	Transmitter extender bracket	1	HW
	CA4, CA17, CA21, CA29, CA47 cables	1 ea	HW

47

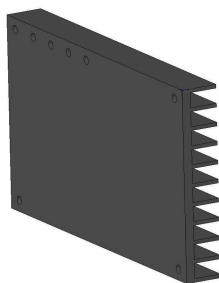

48

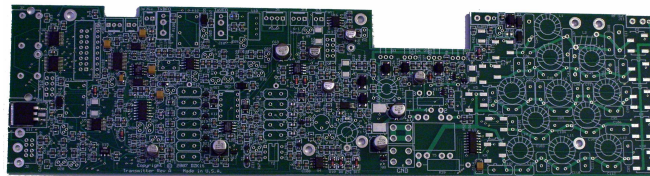

49



50



51



52



53



54



CA21 CONTDATA-TX



CA21

55



RX-TXLINE

CA29

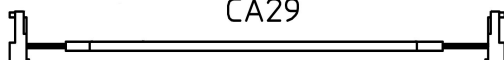

CA47 TX-TUNER/AMP

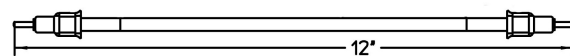

CA47

CA4 DCDIST-TX

CA17 CONT-TUNER

CA17



CA4

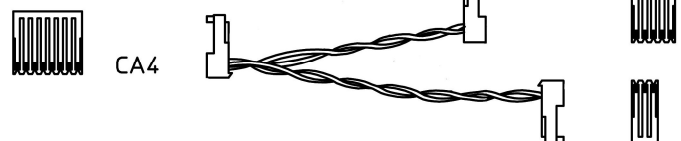



STEP-BY-STEP ASSEMBLY-Transmitter Board

Remove the transmitter board from its antistatic bag. Handle this partially assembled board carefully and observe antistatic precautions to avoid damaging the board.

Check off each of the parts on the parts list that is inside the bags as you install them on the board.

- () Load and solder all 10 surface mount relays, K1-K10 (Bag 3). To solder relays, follow this procedure: Add a small amount of solder to any pad. Place the relay into position with all pins centered on the pads. Re-heat the pad you just added solder to while holding the relay in place. Once it is soldered securely, solder the other pins. Be sure to do this step first, as it is hard to reach some of the relay pins once the toroids are in place.
- () Load and solder power resistors R27, R56, R73 and R85 (Bags 5, 6 and 7).
- () Load and solder surface mount transistor Q11 (Bag 5). Place this SMT part on the pads and solder one pad while holding the part to keep it from moving. Then solder the other pin(s). Some of these parts have 3 pins, some have 2. Finally, solder around the edges of the metal tab, applying enough heat to cause the solder to “wick” under the part.
- () Load and solder small 10uF aluminum electrolytic capacitors C2, C30, C82 and C96 (Bag 1) and large 100uF aluminum electrolytic capacitors C1, C47, C63, C116 and C127 (Bag 2). Make sure the long lead goes in the hole with the square pad, also marked on the silkscreen with a “+”. Clip the leads.
- () Load and solder non-polarized 22uF electrolytic capacitors C84, C121 and C122 (Bag 1). Even though one lead is longer than the other, these parts can be inserted either way. Clip the leads.
- () Load and solder red diodes D12 and D13 (Bag 2). Be sure that the side with the band goes into the hole with a square pad. Clip the leads.
- () Load and solder blue diodes D1, D2, D6 and D15 (Bag 2). Be sure that the side with the band goes into the hole with a square pad. Clip the leads.
- () Load and solder black diodes D3, D4, D5, D11 and D17 (Bag 2). Be sure that the side



with the band goes into the hole with a square pad. Clip the leads.

- () Load and solder diodes D7, D8, D9, D10 and D14 (Bag 5). Be sure that the side with the band goes into the hole with a square pad. Clip the leads.
- () Load and solder diode D16 (Bag 6). Be sure that the side with the band goes into the hole with a square pad. Clip the leads.
- () Load and solder fuse F1 (Bag 2). Clip the leads.
- () Load and solder Q14, a 2N5109 RF transistor (Bag 5), flush with the board. Clip the leads.
- () Load and solder resistor network RN1 (Bag 7). Be sure that pin 1, marked with a dot, goes into the hole with the square pad. *Be very careful not to blob solder onto the small adjacent pads.*
- () Load and solder trimpot RV1 (Bag 7). Clip the leads.
- () Load and solder U10, a TUF-3 RF mixer (Bag 7). Make sure the body is oriented so that it does not extend beyond the silkscreened outline. Clip the leads.
- () If not already done, place a 2-pin Mylar insulator on each of the crystals (Y1-Y19, Bag 8). Insert the crystal on the board and solder one pin while pushing on each crystal to be sure it lies flat against the board. Once secure, solder the other pin. Clip the leads.
- () Cut the 24 AWG bare wire (Bag 8) into three 5" pieces and solder each wire to the top of all the crystals in each of the three groups, then solder the other end of each wire to the pad labeled GND that is near each group of crystals. Do not apply any more heat than necessary to the tops of the crystals.
- () If not already done, place a 3-pin Mylar insulator on filters FL1 and FL2 (Bag 8) and solder the crystal flat against the board. Align the dots on the filters with the asterisk silkscreened on the board. Clip the leads.
- () Read this entire step before soldering connectors! Load and solder each connector, one at a time, including RF connectors and 2- and 3-pin jumpers (Bag 3). Be sure to line up the tabs on the white AMP MTA connectors with the silkscreened bar. Make sure the embossed triangle on the 16-pin connector goes into the square pad. Bend the center conductor pin on the RF connectors so that the connector sits at a 45 degree



angle when inserted into the board. **J12, J13, J16 and J17 mount on the back side of the board. Be sure these lie flat against the board. After soldering, insert jumper shorting bars JS1-12 on the jumper headers. JS8 mounts on the right two pins of JP8.**

NOTE: Unless specified otherwise, all toroids should be built by inserting a wire in from the front as the opening faces you and wrapped clockwise through the core. Most silkscreening on the board is only a rough indication of a generic toroid, not actual winding information.

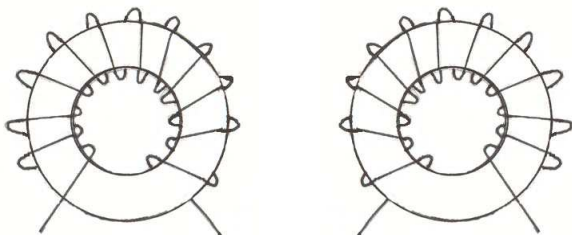

Clockwise

Counterclockwise

- () Repeat the previous step with the eight black toroids (Bag 4). Load and solder these toroids into L5-L12. Clip the leads.
 - L1: 27 turns (18") RED
 - L2: 25 turns (17") RED-ccw
 - L3: 14 turns (10") RED
 - L4: 13 turns (10") RED
 - L5: 13 turns (10") BLACK
 - L6: 12 turns (9") BLACK
 - L7: 12 turns (9") BLACK
 - L8: 11 turns (8") BLACK
 - L9: 10 turns (7") BLACK
 - L10: 9 turns (7") BLACK
 - L11: 8 turns (6") BLACK
 - L12: 8 turns (6") BLACK
- () Locate the four red toroids (Bag 4). Cut the **red** magnet wire into 12 lengths as shown in the table below. Wind the specified number of turns of magnet wire around each toroid. Each time the wire passes through the center is considered 1 turn. Leave about 1/2" of lead extending out from the toroid. Load these toroids into L1-L4. Note that these toroids stand up while L5-L12 lay flat on the board. **L2 must be wound**
- () Measure resistance between the pins on each toroid. They should read less than 1 ohm. If they don't, reheat the connections.
- () Load and solder all silver mica capacitors (Bag 1). Clip the leads. Save two of the large diameter leads.
- () Place two ferrite beads (Bag 4) over a clipped lead from the previous step. Bend the ends of the wire down so that



the resulting inductor fits in the holes for L13. Load and solder this part and clip the leads.

- () Repeat the previous step for inductor L14.
- () Load and solder a T36-1 transformer (Bag 6) at T2. Pin 6 is marked with a dot and goes in the hole with the square pad.
- () Load and solder a T4-1 transformer (Bag 7) at T6. Pin 6 is marked with a dot and goes in the hole with the square pad.

- () Cut 10" of red 24# magnet wire and wrap 9 turns completely around an FT37-43 toroid (the smaller ones in Bag 7). Cut 4" of green 24# magnet wire and wrap 3 turns around the red wire, overlapping it evenly. Leave 1/2" of all leads extending from the toroid. Lay the toroid down and solder its leads at T1. The red wires go in holes 1 and 2. Clip the leads. See pictures below.

Red (primary)

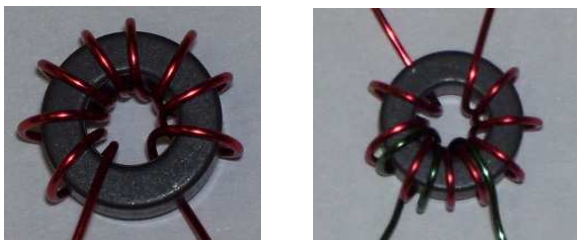

Red (primary) Green (secondary)

T1 construction

- () Cut 13" of red 24# magnet wire and wrap 12 turns completely around an FT37-43 toroid (the smaller ones in Bag 7). Cut 8" of green 24# magnet wire and wrap 8 turns around the red wire. Leave 1" of leads extending out from the toroid. Lay the toroid down flat and solder its leads at T3. Fold the green wires under the toroid and into holes 3 and 4. The red wires go into holes 1 and 2. Clip the leads.

Red (primary)

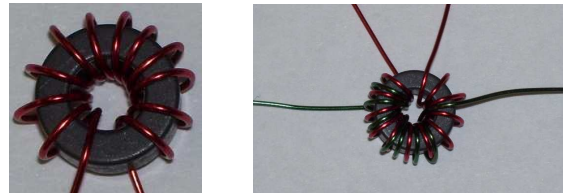

Red (primary) Green(sec)-to sides



Fold green leads under part.

T3 construction

- () Cut 6" lengths of red and green magnet wire. Twist the wires together about 2 turns per inch. Wind 5 turns completely **counterclockwise** around an FT50-43 toroid (the larger one in Bag 8). Stand the toroid up and solder its leads at T4. The red and green leads on the same side of the toroid go in the holes marked 1 and 3, respectively (1=red, 3=green). The other

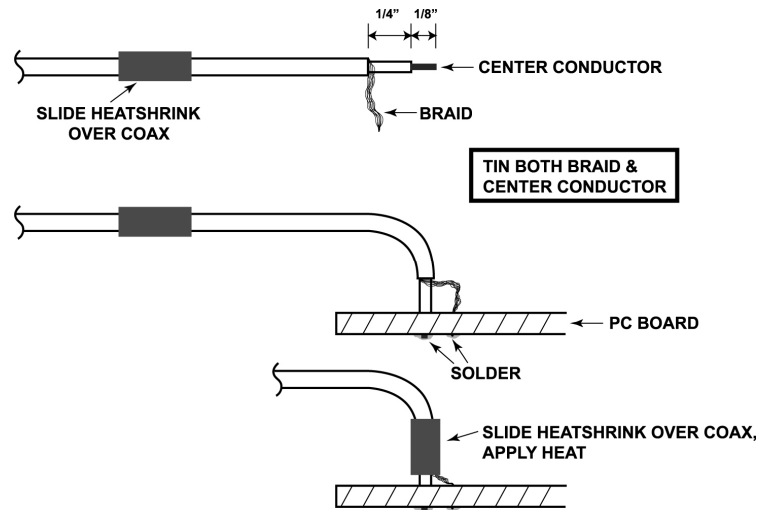
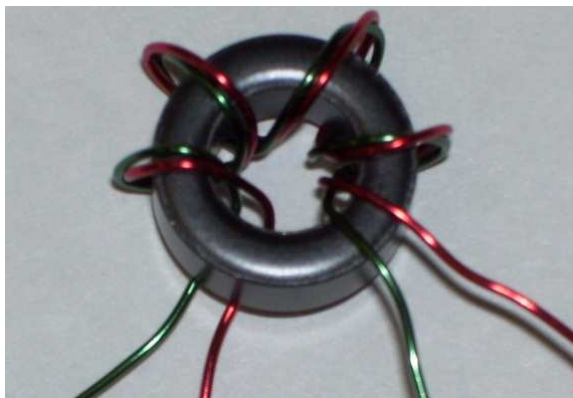

Figure H1. Transverter coax cable wiring

red wire goes in 2. The other green wire goes in 4. Clip the leads.

R39). Solder and clip the leads.



- () Cut two 2" lengths of red magnet wire and feed one through one hole in the core and one through the other. Insert the leads in the remaining holes on each side of the core. See drawing on next page. Solder and clip the leads.

Grn(3) Red(1) Grn(4) Red(2)
T4 construction

- () Locate the gray binocular core (Bag 7). Wind 2 turns of red magnet wire in the center holes and leave 1" extending out from the body of the core. Wind 3 turns of green magnet wire from the other side and leave about 1" extending out from the body facing the other direction. Load the core at T5, with the green wires going into the holes closest to the bottom of the board (adjacent to

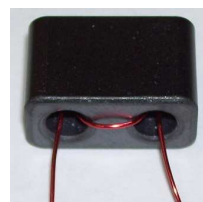

Red(primary)

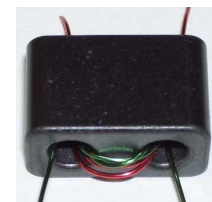

Green(secondary)

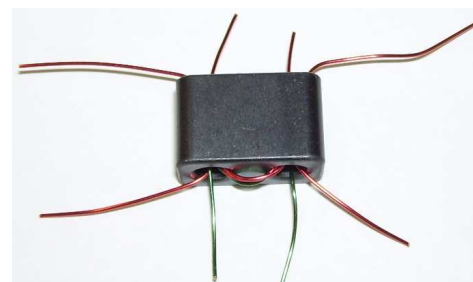

Completed toroid T5



- () Load and solder power resistor R39 (Bag 6).
- () Load and solder relays K12 and K13 (Bag 3).
- () Strip and tin the 8" RG-178/U coaxial cable (Bag 4) as shown in Figure H1 above. On the back side of the board, solder the coaxial cable between the two pads labeled XVT. Connect the shield on each end to the adjacent pad labeled GND.
- () Insert thermistor TH1 (Bag 7) from the **back side of the board**. It must physically touch the heatsink that will be attached next, so position it slightly off the board so that you can bend it into place against the heatsink. Clip the leads on the top side of the board.

Thermalsil insulators (4)

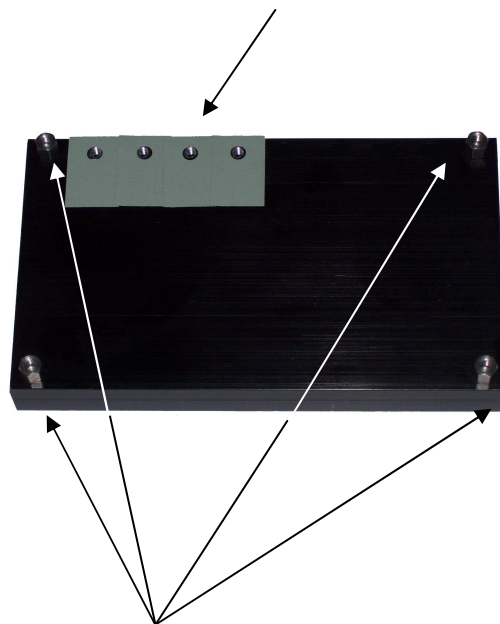

4-40 x 3/16" hex M/F spacers

- () Insert and tighten four 4-40 x 1/4" hex male/female standoffs in the four threaded mounting holes in the heatsink.

Refer to Pictorial H1.

2SC2166 2SC1945/69 TIP31

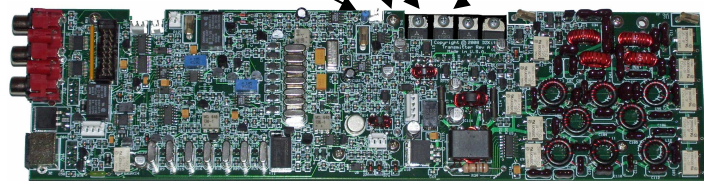

Transmitter board, after construction, top

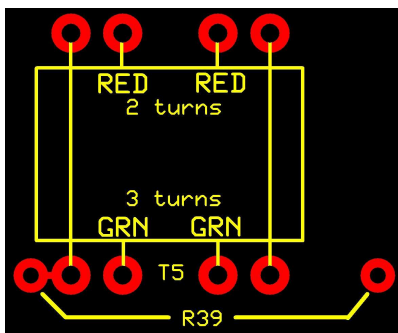

T5 Installation

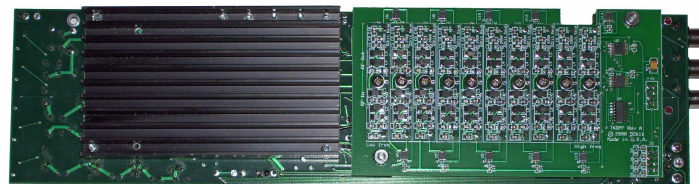

Transmitter board, after construction, bottom

Pictorial H1. Transmitter heatsink



- () Look at transistors Q4 and Q5. These are the RF power transistors that make up the 10W final amplifier. Two different versions are being shipped. 2SC1945 transistors have a pin orientation of “Base Emitter Collector” (BEC). 2SC1969 transistors have a pin orientation of “Base Collector Emitter” (BCE). Now look at the area of the board just beneath the large notch. If you have 2SC1945 transistors, insert a bare wire between pads labeled a and 2a and between pads b and 3. If you have 2SC1969 transistors, use pads a and 3 and pads b and 2b. Do this step twice, once for Q4 and once for Q5. Solder all four jumpers and clip any excess close to the board.
 - () Affix four Thermalsil sticky-back insulators on the heatsink as shown in pictorial H1 so that the large hole in the insulator lines up with the transistor mounting holes.
 - () Place the four power transistors on the heatsink as shown in the pictorial in the order shown using a fiber shoulder washer and a 4-40 x 3/8” screw through each mounting hole and into the threaded holes in the heatsink. *Do not tighten the screws. Make sure the screws are seated against the fiber washers and the washers are in turn seated against the metal transistor tabs. Do not force the screws in, as this could warp the washers. The screws and washers should go in smoothly.*
 - () Place the heatsink into position and note where the transistor leads must be bent up so that they will fit into the holes in the PC board. Remove the heatsink and bend the leads up.
 - () Line up the heatsink mounting holes with the mounting holes on the board as you insert the four transistors into their PC board holes. Secure the heatsink with four 4-40 x 3/16” screws.
 - () Solder the power transistor leads. Clip off any excess lead length.
 - () Build the TXBPF board (Appendix I).
 - () Push the TXBPF board onto connectors J12, J13, J16 and J17 with the notch in the board lined up with the notch in the top of the transmitter board. Secure the board with two 4-40 x 3/16” screws.
 - () If you are adding the transmitter later to an already built Sienna, remove the DCD board and add the SWR meter components to it. See Appendix C2.
 - () Check your work carefully.
- This completes assembly of the Transmitter.



Appendix I: TXBPF Board

PARTS LIST

Item	Part	Description	Qty
1	J1, J3	8-pin 2-row male header	2
2	J2, J14	4-pin 2-row male header	2
3		BPF TF1	1
3		BPF TF2	1
3		BPF TF3	1
3		BPF TF4	1
3		BPF TF5	1
3		BPF TF6	1
3		BPF TF7	1
3		BPF TF8	1
3		BPF TF9	1
3		BPF TF10	1
4		Filter pin socket	20
5		4-40 x 7/16" hex M/F spacer	2
6		4-40 x 3/16" hex M/F spacer	10
7		4-40 KEPS nut	12
8		4-40 x 3/16" PH M/S	10
9		36-pin 1-row male tall pins (cut into 20 1-pin)	1
10		Partially loaded board	1

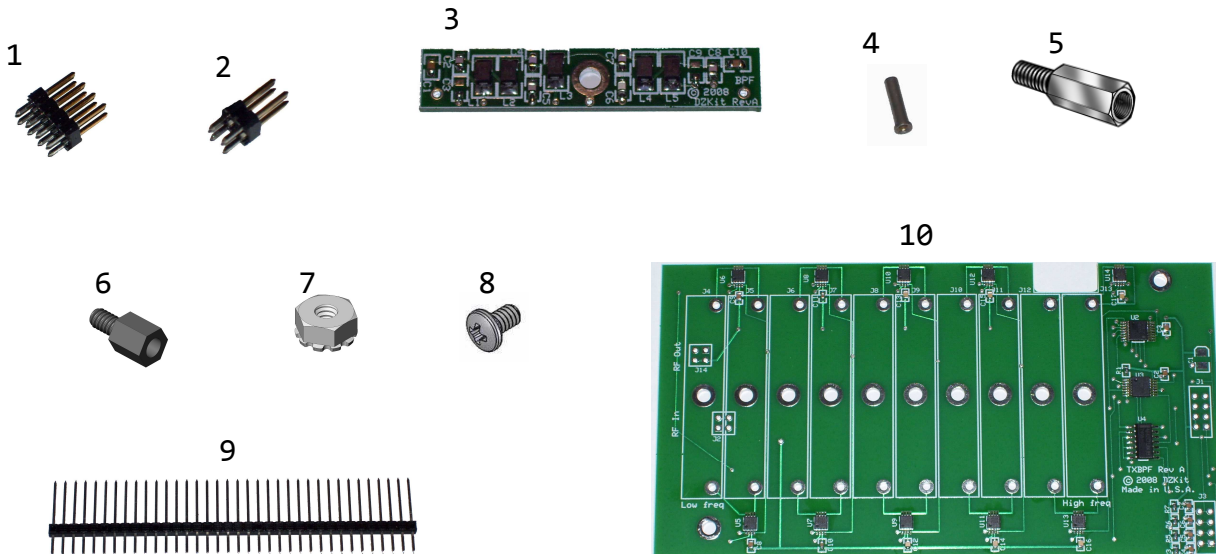



STEP-BY-STEP ASSEMBLY-TXBPF Board

- () Remove the TXBPF board carefully from its antistatic bag. Observe static control precautions while loading this partially-loaded board. The GaAsFET switches that have been loaded are very sensitive devices and will have a direct effect on transmitter performance if they are damaged. Be careful!
 - () *Load all connectors (J1,2,3,14) on the BOTTOM side of the board. Be sure they are mounted flat against the board.*
 - () Attach ten (10) 4-40 x 3/16" hex male/female spacers in the center holes of the 10 filters (marked TX1-TX11). Use 4-40 KEPS nuts on the bottom of the board to secure them.
 - () Cut the 36-pin male header into 20 1-pin pieces and discard the remaining 16-pin piece. Extra pins were included in case you have trouble with any of them.
 - () Locate the 10 transmitter bandpass filters (TX1-TX11). Attach two 1-pin connectors to each of the filters and cut each one to 1/4" as shown in Detail I1. Make sure they are mounted as straight as possible.
 - () Push one filter pin socket onto the end of each of the 20 filter pins.
 - () Place each filter in the corresponding filter locations on the board and tighten each one with a 4-40 x 3/16" screw. If the filter pin sockets do not lie flush with the board, push them down until they do. If you cannot get the screw to seat the board without warping it, remove the board and the filter pin sockets and clip another 1/16" off the end of the filter pins, then try again.
 - () Once all filters are in place and the sockets are flush with the board, solder the filter pin sockets to the back side of the board.
 - () Insert the male threads of two 4-40 x 7/16" hex male/female spacers from the back side of the board into the corner mounting holes and secure them on the front of the board with two 4-40 KEPS nuts.
- This completes assembly of the TXBPF board.



TX1

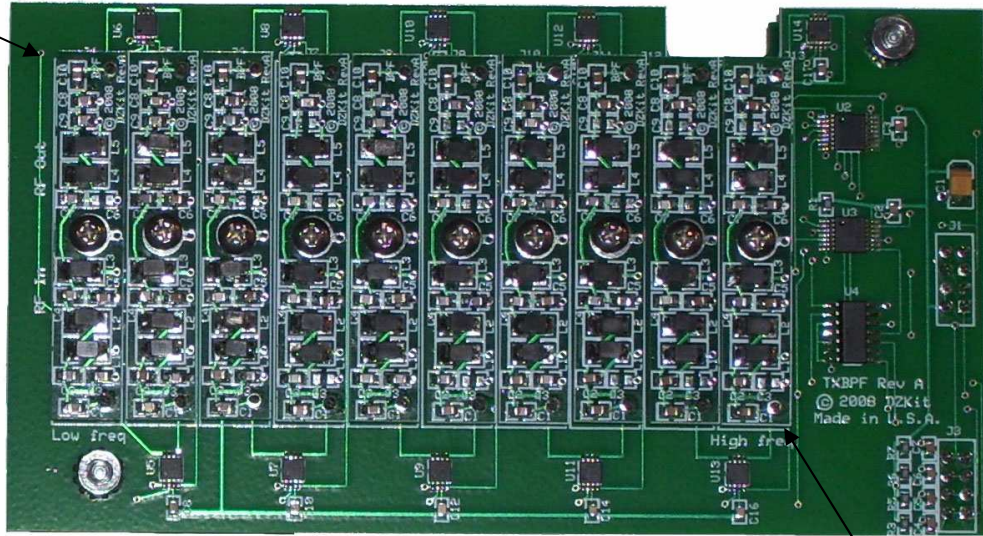

TXBPF with BPF's installed

TX10

Cut to 1/4"

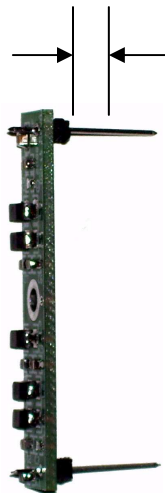

Detail I1. BPF Assy



Appendix J: Option 104: 100W PA

PARTS LIST

Item	Part	Description	Qty	Bag
1	C58	18pF silver mica capacitor (sm)	1	1
1	C44	20pF sm	1	1
1	C53	27pF sm	1	1
1	C62	33pF sm	1	1
1	C60	47pF sm	1	1
1	C55	56pF sm	1	1
1	C50, C57	68pF sm	2	1
1	C63	82pF sm	1	1
1	C38, C47	100pF sm	2	1
1	C56	120pF sm	1	1
1	C52, C59, C61	150pF sm	3	1
1	C32	220pF sm	1	1
1	C40, C41, C54	270pF sm	3	1
1	C36, C37, C42, C45, C48, C49	330pF sm	6	1
1	C34, C46, C70	390pF sm	3	1
1	C43, C51	560pF sm	2	1
1	C35	1000pF sm	1	1
1	C31, C39	1200pF sm	2	1
1	C33	2200pF sm	1	1
3	C9	100pF ceramic disk capacitor	1	1
3	C25	1000pF monolithic capacitor	1	3
2	C12, C13	4700pF 50V monolithic	2	2
2	C3,C4,C5,C22,C26,C27,C28, C29,C30,C64,C65,C66,C67, C68,C72,C73,C74,C75,C76, C77,C78,C79,C80,C82	.047uF 100V monolithic capacitor	24	3
2	C8, C10, C14, C15, C16, C18, C19, C20	.1uF 200V monolithic	8	4
2	C17,C71	1.0uF monolithic	2	5
3	C21, C23, C24	.01uF 500V disk ceramic capacitor	3	2
4	C11, C69	10uF/25V alum. electrolytic cap	2	3
5	C7, C11	100uF/25V alum. electrolytic cap	2	4
6	C6	470uF 25V alum. electrolytic cap	1	4

1



2



3

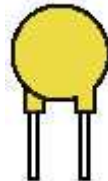

4



5



6





Item	Part	Description	Qty	Bag
7	D6	1N5818 diode (solid, black)	1	5
7	D7, D8, D9, D10	1N914 diode (glass)	4	5
7	D2, D4, D5, D12	1N4007B rectifier 100V 1A DO-41	4	1
7	D1	1N5231B 5.1V Zener diode DO-35	1	1
7	D11	1N5239B 9.1V Zener diode DO-35	1	2
8	D3	1N5404 diode (large)	1	5
9	J3	16-pin 2-row shrouded connector, right angle	1	6
10	J1, J6	2-pin AMP MTA connector	2	6
11	J2, J4, J5	RF connector	3	6
12	K1, K2, K4-K13	SPDT 12V relay	12	5
13	L1, L2, L3, L4	T50-2 toroid (red)	4	6
14	L5-L12	T50-10 toroid (black)	8	6
15	Q5, Q10	2N3904 NPN transistor	2	7
15	Q1, Q4, Q11	2N7000 MOSFET	3	5
16	Q8, Q9	2SC2879A RF power transistor	2	5
17	Q6, Q7	MJE182 NPN power transistor	2	5
18	Q3	TIP31A NPN power transistor	1	5
19	R10	10 ohm 1/4W metal film resistor	1	7
20	R7, R20, R23, R24, R27, R36, R37, R38	51 ohm 1/8W metal film	8	7
20	R6, R8, R22, R28, R39	1K ohm 1/8W metal film	5	4
20	R3, R21, R31, R34	3.16K ohm 1/8W metal film	4	3
20	R1, R2, R9, R26, R29, R33	10K ohm 1/8W metal film	6	6
20	R4	130K ohm 1/8W metal film	1	1
20	R30	1M ohm 1/8W metal film	1	5
20	R5	10M ohm 1/8W metal film	1	2

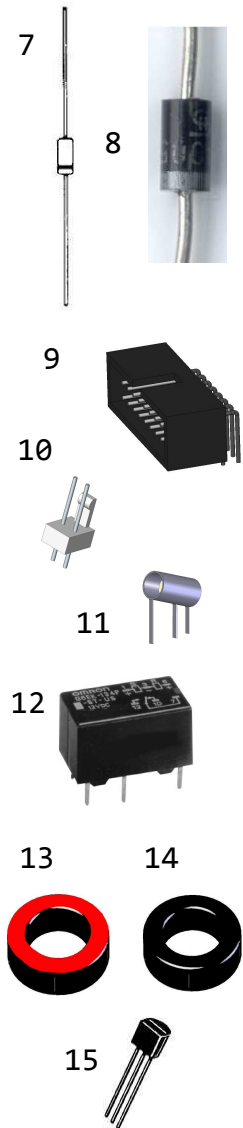

16



17



18

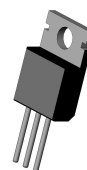

19



20

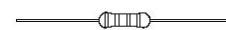



Item	Part	Description	Qty	Bag
21	R13, R14	1.6 ohm 2W metal film resistor	2	4
21	R11, R12	68 ohm 2W metal oxide resistor	2	7
21	R15, R16	10 ohm 2W metal oxide resistor	2	1
21	R17	15 ohm 3W metal oxide resistor	1	3
21	R32, R35	47 ohm 1W metal oxide resistor	2	7
21	R18	300 ohm 2W metal oxide resistor	1	5
21	R25	120 ohm 2W metal oxide resistor	1	2
22	RFC1(A,B)	Ferrite Bead	2	7
23	RN1	Resistor network, .1" centers, 10-pin 10K	1	7
24	RV1	1K trimpot - side adjust	1	7
25	T1	Small binocular core, .5"x.75", wound 9:1CT	1	7
26	T2	Large binocular core, 1"x1.2", wound 1CT:16	1	7
27	TH1	Thermistor - 10K	1	7
28	U1	74HC273 octal D flip-flop	1	5
29	U2	ULN2803 relay driver	1	5
30		Partially loaded board	1	
		22# magnet wire	160"	6
		Wire RG-178B/U Coaxial cable 50 ohm	6"	6
		Small sleeving	6"	3
		Parts used for mounting board to chassis:		
31		Thermasil sticky-back insulator	3	HW
32		Screw - 4-40 x 3/16" PH Phillips M/S	11	HW
33		Hex M/F spacer - 4-40 x 3/16"	4	HW
34		Hex F/F spacer - 6-32 x 1 1/4"	4	HW
35		Hex unthreaded spacer - #6 x 11/16"	1	HW
36		Screw - 6-32 x 1/4" PH M/S	3	HW
37		Screw - 6-32 x 1 1/2" PH M/S	1	HW
38		Fiber shoulder washer	1	HW
39		Heatsink compound (Wakefield 4g pack)	1	HW
40	CA15	2-pin IDC cable	1	HW
41	CA23	Ribbon cable — TUNERDATA-AMP	1	HW
42	CA49	RF cable — AMP-TUNER	1	HW
43	CA50-1, -2	12" 16AWG red wire with insulated terminals	2	HW
44		Fuseholder	1	HW
45		Fuse - 25A 3AG	1	HW
46		Heatsink	1	

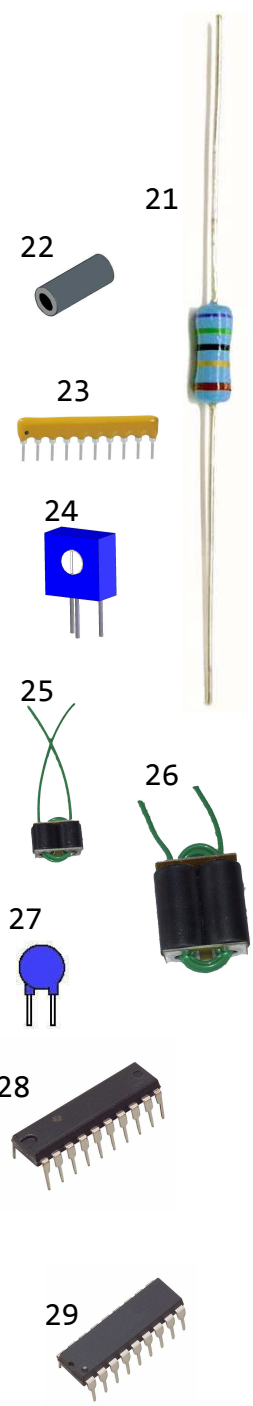

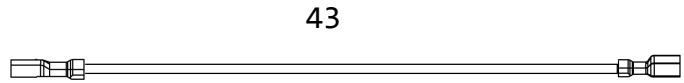
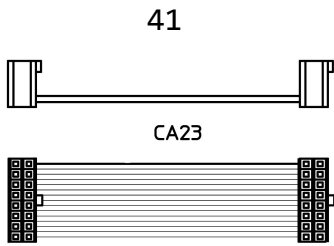
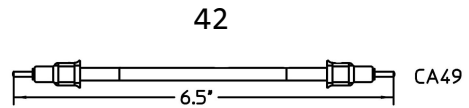
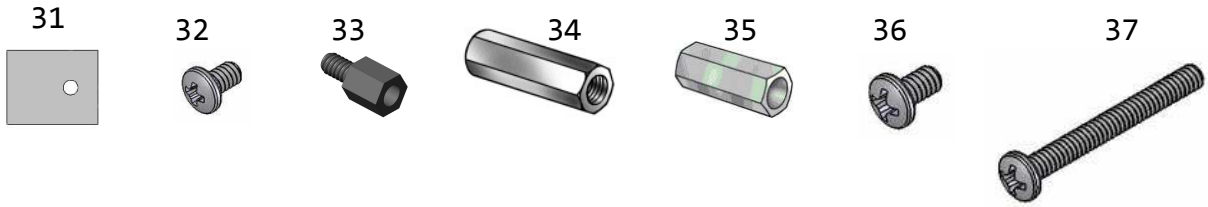

46



STEP-BY-STEP ASSEMBLY-100W PA Board

When loading the following parts, locate the appropriate bag and remove only the specified parts, one value at a time. Check off the parts on the parts list in each bag as you remove them, and then check off each step once you have completed it.

- () Lay T1 on top of the board inside the silkscreened outline, with the leads facing toward the edge of the board. Note that the PC boards that form each side of the transformer have two pads on one side that line up with the pads on the 100W PA board. On the other side, one center pad lines up with a long pad on the 100W PA Board. While holding the part in place, solder one pad of the transformer to the corresponding pad on the 100W PA Board, followed by the other two. Insert the leads into the marked pads and solder them. Clip the leads. It is very difficult to remove this part once installed, so take your time and be sure that it is installed correctly. Use plenty of solder and heat to assure a good contact.
- () Repeat the above procedure for large transformer T2 (Bag 7).
- () Load and solder aluminum electrolytic capacitors C6, C7 and C11 (Bag 4) and C69 (Bag 3). Note that these are not all the same value capacitors. The long lead is positive and must be mounted in the hole with the square pad. Clip the leads.
- () Load and solder resistor network RN1 (Bag 7). Be sure that pin 1, marked with a dot, goes into the hole with the square pad.
- () Load and solder all monolithic and ceramic disk capacitors **except C21** (Bags 1-5). Note that these are not all the same value. Clip the leads. DO NOT load the silver mica capacitors at this time.
- () Cut two lengths of small sleeving (Bag 3) so that when placed on C21's leads, there is 1/4" of exposed lead remaining at the ends. Insert C21 from the **bottom** of the board between the two pads each labeled "C21". Solder the leads from the top side of the board. Make sure no exposed portion of the leads touches any other components. See Detail J3 on page 156.
- () Load and solder all 1/8W, 1/4W, 1W and 2W resistors (Bags 1-7). Clip the leads. Save one of the clipped leads from a 2W resistor.
- () Place two ferrite beads (Bag 7) over a clipped lead from the previous step. Bend the



- ends of the wire down so that the resulting inductor fits in the holes for RFC1. Load and solder this part and clip the leads.
- () Load and solder all diodes (Bags 1, 2 and 5). Make sure the banded side goes in the hole with a square pad. Clip the leads.
 - () Load and solder trimpot RV1 (Bag 7). Clip the leads.
 - () Load and solder 2N3904 NPN transistors Q5 and Q10 (Bag 7). Bend the leads slightly as you insert the parts and line up the flat side with the silkscreening. Clip the leads.
 - () Load and solder 2N7000 MOSFET transistors Q1, Q4 and Q11 (Bag 5). Clip the leads.
 - () Load and solder ICs U1 and U2 (Bag 5). Be sure pin 1, marked by a notch in the IC, goes in the square pad.
 - () Load and solder connector J3 (Bag 6). Pin 1 on J3 is marked by an indented triangle. Line this up with the square pad.
 - () Load and solder 2-pin AMP MTA connectors, J1 and J6 (Bag 6). Be sure to line up the thick side of the connector with the thick silkscreened outline of the part.
 - () Load and solder the RF connectors J2, J4 and J5 (Bag 6). Clip the leads.
 - () Cut the leads on small transformer T1 (Bag 7) to 1/2". Strip 1/8" off the ends.
 - () Locate the four red toroids (Bag 6). Cut the magnet wire into 14 lengths as shown in the table below. Wind the specified number of turns of magnet wire around each toroid. Each time the wire passes through the center is considered 1 turn. Leave about 1/2" of lead extending out from the toroid. Load these toroids into L1-L4. Solder the leads, keeping the soldering iron (set to 800 degrees F) on the leads until the coating melts away and the solder flows onto both the pad and the wire smoothly. This can take about one minute per lead. Clip the leads.
 - () Repeat the previous step with the eight black toroids (Bag 6). Load and solder these toroids into L5-L12. Clip the leads.
 - L1: 27 turns (18") RED
 - L2: 25 turns (17") RED
 - L3: 14 turns (10") RED
 - L4: 13 turns (10") RED
 - L5: 13 turns (10") BLACK
 - L6: 12 turns (9") BLACK
 - L7: 12 turns (9") BLACK
 - L8: 11 turns (8") BLACK
 - L9: 10 turns (7") BLACK
 - L10: 9 turns (7") BLACK
 - L11: 8 turns (6") BLACK
 - L12: 8 turns (6") BLACK



- () Load and solder all silver mica capacitors (Bag 1). Clip the leads. The component value in picoFarads is printed on the body of the cap. For example, a 330pF capacitor is marked 330. Ignore any suffix, such as "J".
- () Load and solder all relays, K1, K2, K4-K13 (Bag 5).
- () Strip the insulation off of one end of the RG-178B/U coaxial cable to a length of 1/2". Using an awl or other sharp tool, open a small hole in the shield near the point where it touches the insulation, and pull the center conductor out through the hole. Twist the shield. Cut 1/4" of insulation off of the center conductor and twist the wires. Tin both of the leads you have just created. If you make a mistake, you can cut the leads off and try again.
- () Cut the coax to an overall length of 5". Repeat the previous step on the other end of the cable.
- () On the top side of the board, insert the center conductor of each end of the coaxial cable into the pads marked "A", and the shields into the pads marked "GND". Solder the leads and clip any excess.
- () Insert and tighten four 4-40 x 3/16" hex male/female spacers into the four mounting holes on the heatsink as shown in Detail J2.
- () Affix three Thermalsil insulators to the heatsink as shown.
- () Place Q8 and Q9 (Bag 5) on the heatsink in the orientation shown in Detail J2. The collectors have an angled cut in the fin. Insert a 4-40 x 3/16" screw into the mounting holes on each transistor and into the threaded holes on the heatsink. Secure the screws but do not tighten them.
- () Place the board over the heatsink, lining up the four mounting holes. Insert two 4-40 x 3/16" screws in diagonally opposite holes to keep it in place.
- () Solder a fin on Q8 and Q9 from the top side of the board, using the large holes on the emitter pads, allowing the solder to "wick" down into the holes. It is only necessary to tack one fin on each transistor at this point, just to keep the parts from moving. See detail J3.
- () Remove the mounting screws from the heatsink and from Q8 and Q9 and remove the board.
- () Solder the other three fins on Q8 and Q9. Apply plenty of solder to be sure the fins



are fully attached to the pads. Re-heat the pad you tacked earlier, applying more solder if necessary.

- () Line up the other three transistors (Q3, Q6 and Q7—Bag 5) in the correct locations on the heatsink. Note where the leads of the transistors need to be bent up to fit in the PC board holes. Bend the leads up and insert them into the PC board holes from the bottom side of the board **but do not solder them yet.**
- () Insert thermistor TH1 (Bag 7) **from the bottom of the board.** Push it over slightly toward the center of the board, but not all the way, so that when the heatsink is attached it will compress the thermistor against the heatsink. **Do not solder it yet.**

() In the next few steps you will attach the heatsink, after which the bottom of the PC board will no longer be accessible, so take a few minutes to check every solder connection! There is a virtually 100% chance that you will find a few pins unsoldered. Better to fix them now than to take the heatsink off and fix them later.

- () Apply a liberal amount of heatsink compound to the bottom metal body of Q8 and Q9.
- () Place the board onto the heatsink, being careful to line up the mounting holes.
- () Re-insert the four screws into the mounting holes for Q8 and Q9 and the four PC board mounting screws.
- () Insert a shoulder washer in Q3's mounting hole.

Thermalsil insulators

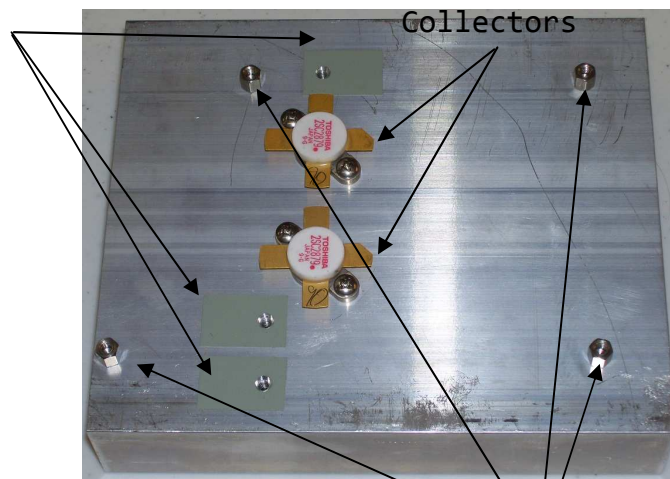

Detail J2.

4-40x3/16"
spacers



- () Gently wiggle Q3, Q6 and Q7 so that their mounting holes line up perfectly with the corresponding threaded hole in the heatsink. Insert a 4-40 x 3/16" screw into the three transistor mounting holes. Make sure as you do this that the screws go in smoothly without any difficulty and that Q3's shoulder washer remains fully inserted in the transistor mounting hole. If you encounter resistance, back off on the screw, re-seat the washer, check to make sure the hole is centered and try again. Tighten the screws, but do not overtighten to avoid damaging the parts.
- () Solder the pins on Q3, Q6 and Q7 and clip their leads.
- () Insert four 6-32 x 1 1/4" hex female-female spacers from the bottom side of the board in the four corner holes of the board and attach 6-32 x 1/4" screws to the top of three of the four spacers. On the spacer that is next to the RF connector marked "Antenna", use a .05" Nylon washer and an 11/16" hex double-female unthreaded spacer and temporarily insert a 6-32 x 1 1/2" screw into the assembly from the top.
- This completes assembly of the 100W power amplifier.

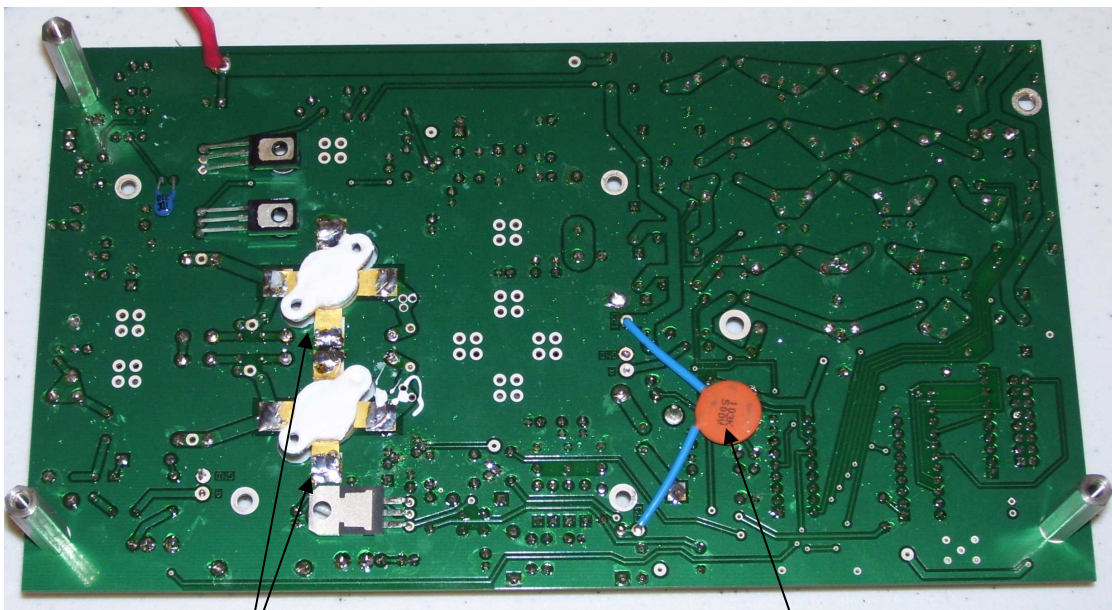

"Tack" solder
Q8 and Q9 here

Detail J3.

C21

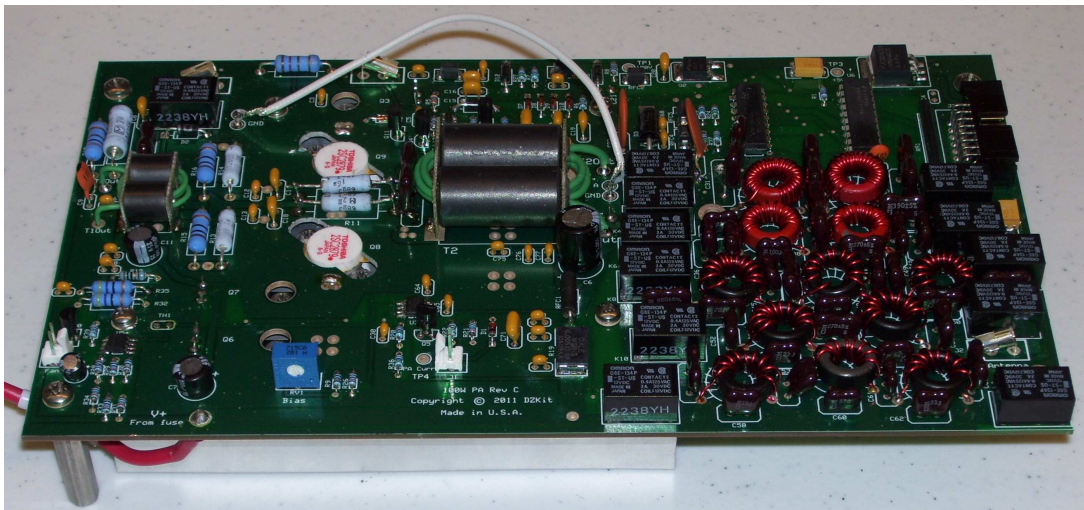

Detail J4.





Appendix K: Installing IF Filters

Refer to Photo K1 on the next page for the following steps.

There are three Intermediate Frequencies (IF's) used in the Sienna:

1st IF: The first IF is at 70MHz (70.455MHz with the optional Inrad 4kHz roofing filter). The Inrad crystal filter can be soldered directly to the Receiver board in the four holes located at "FL1" - the area with a notch. The standard ceramic filter is mounted on a small PC board and also solders to the Receiver board. When soldering either of these filters, pay particular attention to the orientation of the pins: the text on the Inrad filter and on the PC board reads upside down compared to the other text on the Receiver board when installed correctly!

2nd IF: The second IF is at 9MHz and uses only Inrad crystal filters. A 4-pole SSB filter is shipped with all Sienna radios standard, and mounted on a Yaesu-style snap-in "C" board. This filter should be inserted into 9MHz Slot 2 from the bottom of the board. Other optional filters are of two types: the AM filter, which solders and screws di-

rectly to the IF Filter board because of its unusually tall form factor. All other filters snap in from the bottom of the radio into filter slots labeled 9MHz Slot 2, 3 and 4. Although the order is not important, most prefer to arrange them in decreasing bandwidth from Slot 2 through Slot 4. If you purchased a higher quality (more poles) SSB filter, you can install it *instead* of the standard 4-pole unit in Slot 2.

3rd IF: The final IF is 455kHz, and the filters for this IF are of three types:

1. Standard 20kHz ceramic filter. This small black cube is soldered directly to the bottom of the board in Slot 1.
2. Collins mechanical filters. The 5800 Hz mechanical filter, if present, must be soldered into the bottom of the board at Slot 1 instead of the ceramic filter noted above. Other mechanical filters are provided on Yaesu "C"-style snap-in boards.
3. Inrad crystal filters, all of which are mounted on Yaesu "C"-style snap-in boards.



Once filters are installed, the control firmware in the Sienna main microprocessor must be told which filter is located in which slot. If you have a front panel, press the menu button and rotate the small tuning knob until the IF filter choices show up. This screen shows the values installed in the 455kHz slots 1-4:



Once the page you want to change is selected, press the “Page/ Mode” button (which takes you out of Page mode) and then rotate the large tuning knob to the desired slot. Rotate the small tuning knob until the desired bandwidth is shown for the selected slot. Once all filter values have been set, press Menu again to exit menu mode. Allow 10 seconds for the internal read-only-memory to be updated before turning off power. Photo K1 shows a typical installation of crystal, mechanical and ceramic filters.

Note: Sienna’s processor “knows” what the actual center frequency of the available filters is (e.g., 9000.75, 9001.5 MHz). Non-standard choices may not work.

455kHz IF: 20kHz ceramic filter in slot 1



455kHz IF: Collins mechanical filter in slot 2

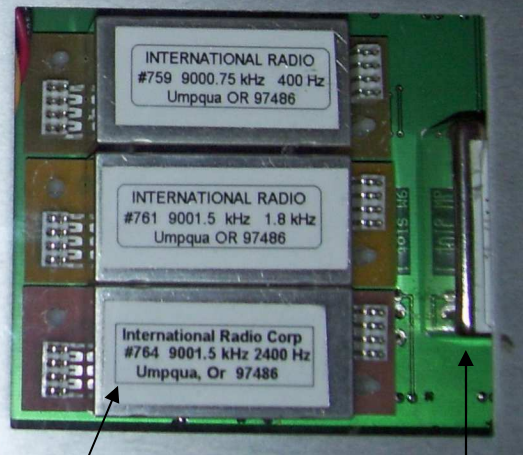

Photo K1: Typical filter installation

9 MHz IF: AM filter in slot 1

Snap-in “C” boards



If you have a front panel-less model of the Sienna, you must enter the filter information by sending commands in the following form:

(Use Hyperterm or other RS-232 communications program at 9600 baud, 1 stop, no parity, no hand-shake)

“IR0;” (if you have the standard 70MHz filter)

“IR1;” (if you have the optional Inrad 70.455MHz filter)

455kHz filters:

“IXnnnn;” n =
0,1,2,3,4,5,6,7,8,9,a,b,c,d
where:
0=20K, 1=5800, 2=2800,
3=2600, 4=2100, 5=2000,
6=1800, 7=1000, 8=500,
9=400, a=300, b=250, c=125,
d=none

9MHz filters:

“IYn;” n = 0,1,2,3,4,5,6,7,8

where:

0 = 6000, 1=2800, 2=2400,
3=2100, 4=1800, 5=1000,
6=400, 7=250, 8 = none

Entries are in slot 1-4 order.

Example:

IX0269; installs the 20KHz filter in slot 1, 2800Hz in slot 2, 1800Hz in slot 3 and 400Hz in slot 4 for the 455kHz filters. If you want to verify that the commands “took”, send just the characters “IR;” or “IX;” or “IY;”. The returned data will tell you which filters it thinks are in those slots.



Photo not available at time of printing

Photo L1. Test Board connections to IF Filter Board



Appendix L: IF Filter Test Procedure

Refer to Photo L1 for the following steps.

- () Assemble the IF Test Board. Check it against the picture on page 162 to make sure the connectors are pointed the right direction.
- () Install jumpers at JP1, JP2 and JP3.
- () Attach the Test Board to the spacer that is located in the center of the IF Filter Board using a 6-32 x 1/4" screw.
- () Connect the power cable coming from J10 on the DCD board (labeled "Rx") to J1 on the Test Board.
- () Do not connect a cable to J2 on the test board yet. This will be done in a later step.
- () Locate the RF cable that has been inserted into the Tx compartment, labeled "TXVFO". Insert the end of this cable into J18 ("9MHz In (Test)") on the IF Filter Board.
- () Connect the cable labeled "IF2" from J19 ("9MHz Out (Test)") to J3 ("RF/IF In") on the Test Board.
- () Connect the antenna input of a monitor receiver to the BNC connector (J4) on the Test Board. If your receiver has an RF attenuator, turn it on.
- () Make certain that all cables that are not in use are not shorting to the chassis or to other components on any boards.
- () Apply power to the radio and press the on/off switch.
- () Measure the DC voltage on pin 7 of J2 (or the side of R1 that is not connected to JP3). It should be +5V +/-5%. (The negative voltmeter lead can be connected to any point on the chassis.)
- () Measure the DC voltage on pin 8 of J1 on the IF Filter Board. It should be the same as your DC input voltage to Sienna's back panel (11-15V). Call this voltage "VDD".
- () Connect the 8-pin control cable coming from J1 on the bottom of the IF Filter board to J2 on the Test Board.
- () Measure the voltage at the junction of R21 and R23 on the IF Filter Board. It should be the same as VDD.



- () Measure the voltage at the junction of R22 and R20 on the IF Filter Board. It should be the same as VDD
- () For units with front panels:

Make sure that you have not activated "Split" mode (Split LED is off). Set the mode to USB and the frequency to 9000.00 kHz. Use the FAST button and the small tuning knob to quickly change frequency. In menu mode, select TXVFO=DspFrq ON. (This sets the TXVFO oscillator to the frequency shown in the display rather than offset by the TXBFO IF frequency.)

For units without front panels:

Connect the RS-232 port and issue the following commands using Hyperterm or any RS-232 remote control program (9600 baud, 1 stop bit, no parity, no handshake):

```
FT0;          { Split off }
MD2;          { USB mode }
FA0000900000;
              { Freq=9.000MHz }
CF1;          { Test Mode On }
```
- () Tune around the frequency with the monitor receiver until you hear a tone in the speaker. (For faceless units, send the FA command above, changing the frequency by 10 Hz at a time.)
- () Change the filter slot settings by changing jumpers JP1 and JP2 as noted on the Test Board (for whichever slots you have installed filters) and verify that you can still hear the tone. The amplitude may vary slightly from one filter to the next.
- () Remove the TXVFO cable from J18 on the IF Filter Board and reconnect it to J4 ("455kHz In") on the IF Filter Board.
- () Remove the IF2 cable from J19 on the IF Filter Board and reconnect it to J5 ("455kHz Out") on the same board.
- () For units with front panels:

Set the display frequency of Sienna and the monitor receiver to 455.00 kHz. Use the FAST button and the small tuning knob to quickly change frequency.
- () For units without front panels, send the command:

```
FA00000455000;
              { Freq=455kHz }
```
- () Verify any 455 kHz slots that you have installed in the



same way you verified the 9MHz slots.

- () Remove JP3 on the Test Board. This forces the IF Filters to be disabled, and the input and output connections are simply terminated in 50 ohms. It does not matter whether JP1 and JP2 are installed or not.
- () Measure the voltage at the junction of D10 (cathode), D36 (anode) and C47. It should be approximately half of the VDD.
- () Measure the voltage at the junction of D9 (cathode), D27 (anode) and C46. It should be approximately half of VDD.
- () Disable test mode (“CF0;” command for faceless Siennas or menu item TXVFO=DspFrq Off).
- () Turn off the radio and remove the Test Board. Disconnect all cables from it.





Appendix M: RXBPF Test Procedure

- () Connect the Receiver power cable between J10 (“Rx” - 5-pins) on the DCD Board and J17 (“From DCD (test)” - 4-pins) on the RXBPF Board.
 - () Connect the bottom of the two connectors on the ribbon cable to J5 on the RXBPF board.
 - () If your Sienna has Antenna A or B connectors on the back panel, connect the RXBPFMAIN RF cable from the Main Antenna input on the RXBPF board to either small RF connector in the center of the DCD Board (J11 or J14) and connect an antenna to Sienna’s Antenna A or B connector. If A or B are not available, attach an antenna to the Rx Ant connector.
 - () Attach the Test Board to the spacer that is located in the center of the RXBPF Board using a 6-32 x 1/4” screw.
 - () Do *not* connect power to the Test Board, and do not connect the IF Filter cable to the Test Board.
 - () Connect the antenna input of a monitor receiver to the BNC connector on the Test Board.
 - () Connect the RF1 cable between J4 (“RF Out”) on the RXBPF board and J3 (“RF/IF In”) on the Test Board.
 - () Set the “Cal/Rcv” switch on the RXBPF board to the “Rcv” position.
 - () Make certain that all cables that are not in use are not shorting to the chassis or to other components on any boards.
 - () Apply power to the radio and press the on/off switch.
- If you have a full front panel, select any frequency and set your monitor receiver to the same frequency.
- If you are using a remote control model, connect the RS-232 port and issue the following commands using Hyperterm or any RS-232 remote control program (9600 baud, 1 stop bit, no parity, no handshake):
- ```
FA0000x000000;
 { Freq=x.000MHz }
```
- ( ) The above steps pass an antenna signal through the bandpass filters, preamp(s) and attenuator. Any signals



you can hear with an antenna connected to your monitor receiver should still come through fine as long as Sienna is set to the same frequency. As you change frequencies in Sienna, different bandpass filters are engaged. Verify that signals in your monitor receiver can be heard as you select a frequency in each of the 10 bands (and tune your monitor receiver to the same range of frequencies):

0-1.8 MHz  
1.8-3 MHz  
3-4 MHz  
4-6.3 MHz  
6.3-8.4 MHz  
8.4-11 MHz  
11-16 MHz  
16-20 MHz  
20-24 MHz  
24-30 MHz

Note that if you select, say, the 11-16 MHz band in Sienna but set your monitor receiver to, say, 3.5MHz, the monitor receiver should not pick up signals nearly as well as

when Sienna is tuned to a frequency between 3 and 4 MHz.

- ( ) You can make signals stronger or weaker by engaging the preamps and attenuator. From the front panel, simply push the “Preamp1” button to engage the first preamp and then the “Pre2/Atten” button to get both of them. In each case you should be able to hear relays click on the RXBPF board and the signal should get louder. Press just the “Preamp1” button again to turn off the preamps and turn on the Attenuator. You should then hear the signal get much weaker. If you do not have a front panel model, use the following commands instead:

```
RA00; { Attenuator off }
PA0; { Preamp 1 and 2 off }
PA1; { Preamp1 on, 2 off }
PA2; { Preamp1 and 2 on }
RA01; { Atten on, preamps
 off }
```

- ( ) Turn off the radio and remove the Test Board.







# DZ COMPANY

LOVELAND, COLORADO

*UNIQUE ELECTRONIC EQUIPMENT IN KIT FORM*