

PRICE: \$10.00

DZ COMPANY · LOVELAND, COLORADO

# DZKIT

## ASSEMBLY MANUAL



**SIENNA**  
**HF TRANSCEIVER**

## DZ COMPANY CONTACT INFO

Orders, parts, phone assistance .....(970) 667-7382

Email orders ..... sales@dzkit.com

Email technical support ..... support@dzkit.com

Web site ..... www.dzkit.com

Mail:

DZKit

710 Grove Ct.

Loveland, CO 80537

## YOUR DZKIT 90-DAY FULL WARRANTY

---

During your first ninety (90) days of ownership, DZ Company will replace or repair free of charge—as soon as practical—any parts which are defective, either in materials or workmanship. You can obtain parts directly from DZ Company by writing us, emailing us or telephoning us. And we'll pay shipping charges to get those parts to you—anywhere in the world.

We warrant that during the first ninety (90) days of ownership, our products, when correctly assembled, calibrated, adjusted and used in accordance with our printed instructions, will meet published specifications.

You will receive free consultation (except for the cost of your long distance phone call) on any problem you may encounter in the assembly or use of your DZKit product. Just drop us a line, email us, give us a call, or visit our website and click on "Support". That will give you access to free on-line support and a discussion group. Sorry, we cannot accept collect calls.

Our warranty, both expressed and implied, does not cover damage caused by the use of corrosive solder, defective tools, incorrect assembly, misuse, fire, customer-made modifications, floods or acts of God, nor does it include reimbursement for customer assembly or setup time. The warranty covers only DZKit products and is not extended to non-DZ allied equipment or components used in conjunction with our products or uses of our products for purposes other than as advertised.

If you are ever dissatisfied with our service—warranty or otherwise— or our products, please write or email the president, Brian Wood, W0DZ, and he will make certain your problems receive prompt, personal attention.

THE DZ COMPANY, LLC  
LOVELAND, CO 80537

Assembly

Of the



Sienna HF Transceiver



DZ COMPANY  
LOVELAND, COLORADO

Copyright © 2008  
DZ Co.  
All rights reserved

6-25-08

Sienna

---

## TABLE OF CONTENTS

Introduction .....	4
General assembly/safety notes.....	6
Step-By-Step Assembly	
Chassis, DC power, PC, Tuner ..	14
Initial tests .....	30
Meter preparation .....	32
Front Panel integration .....	34
Front Panel tests .....	44
Receiver Integration .....	46
Receiver alignment/test .....	53
Transmitter integration .....	56
Transmitter alignment/tests.....	58
100W PA Integration .....	60
100W PA alignment/tests.....	62
Final assembly .....	66
Appendix A: PCPS Board .....	68
Appendix B: RS232 Board.....	72
Appendix C: DCD Board .....	74
Appendix D: Tuner Board .....	82
Appendix E: Front Panel Board.....	86
Appendix F: IF Filter Board .....	88
Appendix G: RXBPF Board.....	94
Appendix H: Receiver Board .....	102
Appendix I: Transmitter Board.....	108
Appendix J: TXBPF Board .....	118
Appendix K: Option 104: PA .....	122



# INTRODUCTION

The Sienna is a revolution in HF transceivers. The time-tested triple-conversion receiver design assures general coverage receive with no dead spots and excellent image rejection. It also has very good dynamic range by virtue of a 4KHz roofing filter at the 70.455MHz first IF, and compatibility with a wide variety of high performance crystal filters and Collins mechanical filters at the 2nd and third IF to provide excellent selectivity. We've also added innovations in AGC control, bandpass filtering with GaAsFET switches instead of PIN diodes, and the ability to run full-duplex and cross-band at HF frequencies.

The Sienna is also a study in duality: dual preamps, dual keying (manual and paddle inputs available at the same time), dual audio (headphones and speakers available at the same time), dual receive (front panel control of an external secondary receiver), and dual backlit analog meters, which give the rig a nice glow that harkens back to the early days of radio when all radios glowed. Dual micro-processors are in total control of the radio.

And now, for the first time, with an *optional* internal PC, it is possible to connect a keyboard, mouse and display to your transceiver and add digital modes, logging, rig control, file transfer via LAN or USB and much more, at a reasonable price, and without adding any external rig interface equipment. It accomplishes this by means of a tiny but powerful personal computer that runs a com-

mon operating system—Microsoft® Windows® XP Embedded or Linux. This “embedded PC” is a fully functional personal computer with O/S stored on Compact Flash. It also has on-board sound card, Ethernet networking, COM ports, VGA display, PS/2 keyboard/mouse, USB and more. And it's expandable, with plug-in MIO boards that offer even more features, such as dual display and 6 Watt stereo speaker outputs.

But unlike some SDR radios that are totally controlled by PCs, the Sienna does not *need* the PC. Even without it, the Sienna functions as a full-featured HF radio. The twin micro-processors in Sienna's controller run the radio. There's no waiting for the PC to boot when you turn the radio on unless you want to use the features *added* by the PC, and no need to do a “shutdown” on the PC when you turn it off, thanks to the industrial “embedded” PC — one that was designed for instruments.

The Sienna can be built in several stages and in several combinations. This manual is thus a complete assembly manual for the fully loaded Sienna. As you upgrade your Sienna, you can still use this manual as a complete reference.

Thanks for trusting in DZKit to provide not only unique electronic products, but to give you hours of building fun too.





## General Assembly Notes

1. Most screws in this kit are Phillips Panhead Machine Screws. For simplicity, we refer to them simply as “screws” unless a different style is used. These may be stainless steel or zinc-plated steel.
2. All sheet metal parts are attached to each other using 6-32 x 1/4” screws that are inserted into captive fasteners that have been pressed into the sheet metal by the factory. You will not need to use nuts and lockwashers.
3. Most PC boards attach to the sheet metal using 6-32 x 1/4” screws but there are some exceptions, which are explained in the steps.
4. As you tighten a screw, it is very important that you do not strip the threads. All screws should fasten smoothly without resistance. If a screw appears to be hard to fasten, something else is probably wrong—a cable could be in the way, you are trying to use the wrong size screw or something else is wrong. **DO NOT FORCE SCREWS!** Instead, inspect the assembly carefully and try to see why you are having difficulty.
5. A PC within arms reach of your workbench is essential to helping you locate the parts on the boards. Shipped with your kit is a CD-ROM containing the PCB layout files for all boards (without traces). To find the location of a part, simply install and run the “ExpressPCB” program (free download from [www.expresspcb.com](http://www.expresspcb.com)) and open the board you wish to work on. Press “Ctrl-F” to find a part, and then enter it in the box that pops up (e.g., “R1”, without the quotes). The program will show you exactly where that part is located. If you do not have a PC nearby but have ordered the internal PC for the Sienna, you can run this program on it once you have installed the PC (which is done in an early step). Take a few minutes to familiarize yourself with this program before beginning construction. You can also find parts manually by just looking for the part on the silkscreen, but on the denser boards, this can take a long time. We highly recommend using ExpressPCB to locate parts.
6. There are three large sheet metal brackets. Two are identical and are placed opposite each other with the lips on the top, bottom and back facing each other. These brackets are referred to as “large bracket left” and “large bracket right”. The other large bracket runs from side



- to side in the front, attaching to the other brackets. It is called the "front bracket".
7. All references to left and right, front and back are with the chassis in an orientation such that the front of the radio faces you. The large openings on the bottom of the chassis are to the right, with the side lips pointed up.
  8. Each circuit part has its own component number (R1, L4, Q3, etc.). R1 on one assembly will not be the same as R1 on a different assembly, so be sure you are looking at the right set of parts when comparing part numbers with the printed parts list. Check off each part at the beginning of each section to make sure all the parts are there. If you find any missing, give us a call or email us and we will rush a replacement to you.
  9. Most electronic kits that are returned for service have poor soldering jobs. *Please* take a moment to familiarize yourself with proper soldering technique. And do not, under **ANY** circumstances, use corrosive ("acid-core") solder! That will void your warranty and render your kit inoperative. Also be sure to avoid the use of products that may be called
  - solder but are really glue. Soldering should only be done in an area with good ventilation and with a properly heated soldering iron.
  10. Resistors are identified by their values in Ohms, Kilohms (K) or Megohms (M) and by color codes. Your kit uses resistors of several types. Axial leaded resistors have color coded bands on them. For 5% resistors, the first two bands represent the numeric value and the third band represents a multiplier, which is a power of 10. Thus, a 56 Ohm resistor is Green-Blue-Black. A 10KOhm resistor is Brown-Black-Orange, and so on. The fourth band is the tolerance – no band represents 20%, a silver band 10%, and a gold band 5%. Your Sienna uses mostly one percent or better resistors, which have 4 bands for the value. A 4.75K resistor is Yellow-Violet-Green-Brown. We have placed resistors of given types in individual bags for you, but should they get mixed and you have trouble reading the color code, we recommend an inexpensive volt-ohmmeter be used to check the values. A fluorescent light is also useful to "bring out" the colors, and a



Most kit builders find it helpful to separate the parts into categories for quick identification. Muffin tins and egg cartons serve this purpose admirably.



magnifying glass is also handy.

11. Capacitors are identified by their type—(disk, polystyrene, polypropylene, electrolytic, trimmer, etc.) and capacitance values are in microfarads ( $\mu\text{F}$ ) or picoFarads ( $\text{pF}$ ). Polarized types have the positive pin marked on the silkscreen and have a square pad.
12. Inductors are represented either by their inductance in nanoHenries ( $\text{nH}$ ), microHenries ( $\mu\text{H}$ ), milliHenries ( $\text{mH}$ ) or by the number of turns in the coil if you are doing the winding.
13. Diodes are marked with a band on the cathode end. The PC boards have a bar silkscreened across one side of the component outline and a square pad which identifies the cathode.
14. Transistors have either a tab or a flat side that you can match to the silkscreened component outline. Most transistors will need to have their leads “sprung” a little to fit in the holes. Do so carefully to avoid breaking the leads off.
15. ICs have a notch, beveled side and/or a dot representing the side containing pin 1. When you hold an IC with the notch pointing up or the beveled side to your left, pin 1 is in the upper left corner. The silkscreened outlines on the

board all have notches and pin 1 also has a square pad.

***It is CRITICAL that you mount polarized parts correctly! Double check your work to be sure that all such parts match the photos. See Detail 1.***

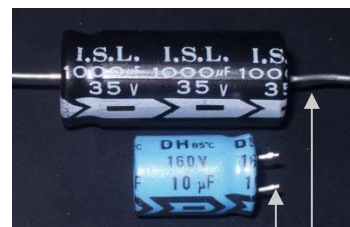
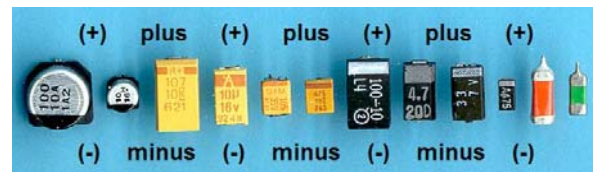
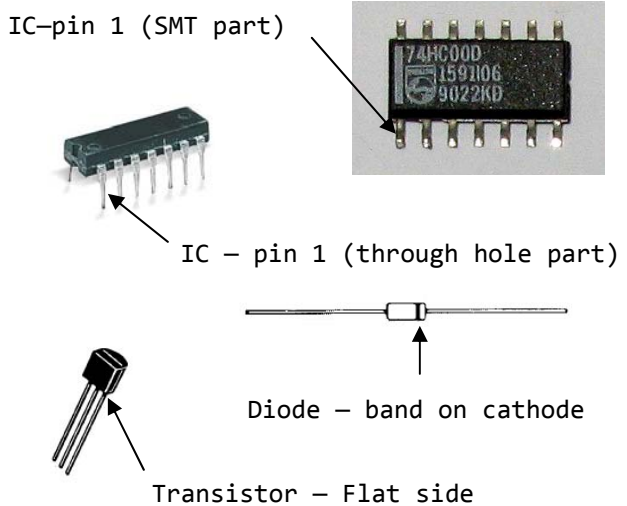

Electrolytic capacitors - negative side

Detail 1. Identifying polarity of diodes, transistors, ICs and polarized capacitors.



## Abbreviations and definitions of terms used in this manual:

PC = Personal Computer

PCB = Printed Circuit Board

PH = Panhead

FH = Flathead

M/S = Machine Screw

PCB-mt = Printed Circuit Board mounting

AMP MTA = Tyco Electronics connector with .1" or .156" pin spacing

Ribbon cable = Flat, gray cable with connectors on each end

Header = PCB-mounted connector

CA = Cable Assembly

## A word about what lies ahead...

This manual is designed to allow you to build confidence in your kit-building ability as you go along. You start by building the DC power distribution circuitry, which is the simplest of all the circuitry. You then install this board on the chassis. You will then be able to turn on the power and measure some voltages. If you purchased the PC, you will then install it, build and attach its DC power supply, power it up and see it boot. This will give you confidence that the kit-building is progressing normally. You will also be able to use the PC to help you locate parts on the rest of the boards using the PCB layout files that we have included. The project continues with building of the front panel circuit board and integration with the pre-assembled controller board. At that point, you will be able to see the front panel light up and you will be able to experiment with the front panel controls. Once all that works, you will build and install the receiver's IF and bandpass filter boards. Next you will finish building the partially pre-assembled receiver. At this point, you will be able to test and align the receiver and use the built-in keyer. You might even want to take a break and spend a few hours using it, just for fun! Assembly continues with construction of the partially assembled transmitter. The transmitter and receiver boards are the most complex, which is why they have been saved for last. But once you get to them, you will have great confidence that you have built the radio correctly to that point. So let's get started!

***NOTE: If you would prefer to build all the boards first, you may go directly to the Appendices and do so.***



## KIT-BUILDING PROCEDURES

The steps involved in building a kit are listed below. Be sure to follow them and you will have a lot of fun building, aligning, testing and using your kit.

1. **Do a parts inventory.** At each major section and in the Appendices, there's a list of parts used in that section (or that will be used shortly). Check off each part to be sure you are not missing anything. Our method of bagging parts is different from all other kit vendors and will make the task much faster and less error prone. But despite our valiant efforts, mistakes can happen. If you are missing any parts, call or email us and we'll rush replacements to you immediately.
2. **Pay attention to soldering techniques.** Keep your soldering iron clean by using a wet sponge, use appropriate heat and maintain heat long enough to make good solder joints. Solder problems are the number one cause of problems when building electronic products (not just kits!), so try extra hard to do it right.
3. **Take your time!** We know you want to get it done and start using it, but doing it wrong will only delay that moment. Before you start, set up a ventilated, static-free work area with enough room to build the kit. Prepare parts bins and get the tools you will need (needle-nose pliers, wire-cutter, wire stripper, Phillips head screw drivers, wrenches, soldering iron, solder, insulated tool, awl or other sharp-ended tool, scissors, magnifying glass, etc.) Open bags only when they are called for so parts don't get inter-mixed. If you're tired, take a break. Enjoy building your kit!
4. **Make sure that you are loading the part that's called for in the right holes.** Once loaded, it can be hard to find a misloaded part. Be especially careful to load integrated circuits the right direction. If you are not sure about any step, call us!
5. Once you've done a step, **put a checkmark inside the parentheses.**
6. **After you have assembled a circuit board, take a moment (just one) to marvel at your handiwork, then spend a few more minutes critiquing it!** Check for solder bridges, unsoldered or insufficiently soldered connections, solder blobs (especially on insulated magnet wire used on toroids), loose screws and electronic parts, reversed polarized components, etc. Sometimes it helps to have a friend check your work.
7. **For an extra fee,** you can send your completed boards to us for inspection and test. We'll let you know if we find any problems. This will delay final assembly, but for complicated and expensive kits, you may find the peace of mind re-assuring. We want you to succeed!



## Safety First!

Your safety is of utmost importance to us. Please read this information before you get started, and remember these rules as you continue building and testing your Sienna.

1. Always have a healthy respect for electricity. While the voltages present inside the Sienna are not lethal, high currents are available (up to 30 Amps when the 100 Watt amplifier is used). Use a power supply with overcurrent foldback or crowbar protection so that in case of high currents the supply will shut down. Set the output current only as high as necessary for a given step.
2. When measuring voltages inside electronic equipment, it is generally a good idea to use only one hand, wear rubber-soled shoes and avoid areas with standing water. However, remember that slightly humid environments can prevent static electricity that could damage the electronic parts! Use a humidifier in dry climates.
3. Do not work on powered electronics by yourself if at all possible. Have a parent, spouse or friend nearby. If you must work alone, keep a telephone handy in the event you run into problems.
4. Soldering irons are hot. They can burn your skin and cause damage to workbenches and carpets. We recommend you use one with an automatic shutoff in case you forget to turn it off when you are done.
5. Do not work on electronic projects when you are tired. We know you want to finish it, but accidents are more likely when you are tired. Take breaks! Be careful!
6. Use proper ventilation in your work area. Solder contains tin and lead (or tin and silver), and solder fumes should not be allowed to “hover” near your work. Open a door or window, use a fan, and be cognizant of the potential dangers.
7. When clipping leads, use eye protection and/or be sure to direct the flying leads down into a nearby trash can. As you gain experience clipping component leads, you will learn how to clip them so that they fall harmlessly away from the board.
8. Be careful not to cut yourself when handling sharp objects such as connectors and sheet metal. Keep some tissues, bandages and antibiotic ointment nearby in the event of an injury.
9. This may sound obvious, but do not insert any parts in any portion of your body no matter how good they may smell.
10. Use common sense in dealing with unfamiliar things. If you don't understand something, call us or ask a friend for help.



# SOLDERING INSTRUCTIONS

Poor soldering accounts for almost 90% of all kit building problems. The photographs below show examples of the most common types of bad solder connections and a good one. If you locate any of these bad solder connections in your kit, correct them as described. Study this section carefully before you start building your kit.

**Solder blob.** In this example, solder flowed onto a lead, but the heat was not maintained long enough for it to flow onto the circuit board pad. Solution: re-heat the connection, touching the iron to both the component lead and the pad at the same time.



Use a good quality, variable temperature soldering iron set to 750 degrees F and non-corrosive, rosin core solder to assemble your kit. Keep the sponge damp and wipe the tip on the sponge after each solder step.

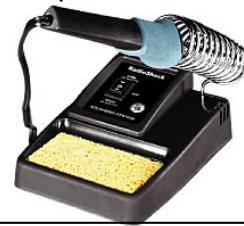

**Solder bridge.** Solder that stretches from one trace to another creates a short circuit. Solution: Hold the board upside down and reheat the area. The excess solder will flow down the soldering iron. Another solution is to use a “solder sucker” or solder wick to remove excess solder. Solder suckers work well one or two times on a given connection. If used too much, they can pull pads and traces off of PC boards.

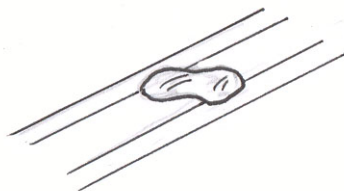

**Good solder connections.** A good solder connection looks like this. Solder flows evenly onto both the part and the PC board or chassis component. It is shiny and even, not lumpy and dull. Component leads that are properly soldered can not be moved in the hole.

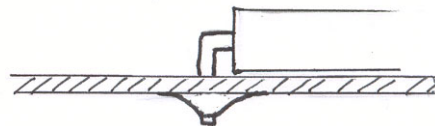



## STATIC PRECAUTIONS

Many of the components in your kit can be damaged by exposure to static electricity. Please read this page to familiarize yourself with the causes of and solutions to this problem.

When the climate is dry, you can generate thousands of volts simply by walking across a carpet. When you then touch a metal object you can feel the effects of this as you draw a spark! That same spark, often too small to see or feel, can destroy sensitive electronic components. You **MUST** take precautions when working with electronics to prevent damage.

The best solution is to outfit your workbench with anti-static devices – floormats, grounded soldering irons, and workmats with grounded wriststraps. If these are not practical for you, the very least you should do is to discharge yourself to ground after you sit down and before you touch any electronic items, by touching a grounded object such as the corner of a wall.

In a dry environment, simply standing up after sitting in a non-grounded chair can also charge you with electricity. If you stand up to stretch, for example, be sure to re-ground yourself before getting back to work.

All electronic components are susceptible to static, but semiconductors and assembled boards containing semiconductors are the most prone to damage. These include diodes (including light-emitting diodes [LEDs]), transistors and integrated circuits (ICs).

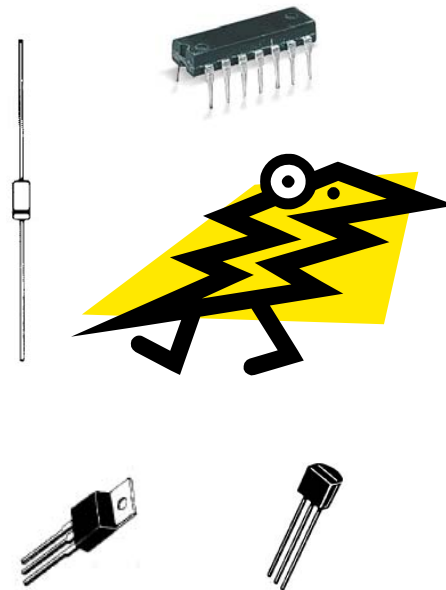

**You are a walking lightning bolt! Be careful!**



# Chassis Parts

Item	Description	Qty
1	Connector — SO-239 RF chassis mount	2
2	Connector — RCA phono chassis mount - red	1
2	Connector — RCA phono chassis mount - black	1
3	RTV silicone adhesive	1
4	Gas discharge tube	3
5	Anderson Powerpole mounting clamp	1
6	Polycarbonate overlay - 1 meter	1
7	Meter face - Multipurpose	1
8	Knob-small	10
9	RIT Knob	1
10	Tuning knob	1
11	Foot - front 1.00 X .75"	2
12	Foot - back .28 X .625"	2
13	Board Guide - 6"	1
14	Screw - 6-32 x 1/4" PH Phillips thread-cutting S/T	6
15	Screw - 6-32 x 1/4" FH Phillips Black M/S	6
16	Screw - 6-32 x 1/4" PH Phillips Black M/S	4
16	Screw - 6-32 x 1/4" PH Phillips M/S	62
16	Screw - 6-32 x 1/2" PH Phillips M/S	2
16	Screw - 6-32 x 3/4" PH Phillips M/S	2
16	Screw - 6-32 x 7/8" PH Phillips M/S	2
16	Screw - 6-32 x 1" PH Phillips M/S	4
16	Screw - 6-32 x 1 1/4" PH Phillips M/S	2
17	Screw - 10-32 x 5/8" PH Phillips M/S	1
18	Screw - 4-40 x 3/16" PH Phillips M/S	2
19	Screw - 2-56 x 5/8" PH Phillips M/S	2



16: various lengths



Item	Description	Qty
20	Jackscrew - 4-40 x 3/16" x 5/16" brass	2
21	Hex M/F spacer - 6-32 x 7/16"	2
21	Hex M/F spacer - 6-32 x 1/2"	6
21	Hex M/F spacer - 6-32 x 5/8"	12
22	Hex F/F spacer - 6-32 x 2"	1
22	Hex F/F spacer, 4-40 x 1 1/4"	1
23	Spacer, unthreaded, #6 x 9/32"	2
24	Washer, Nylon - #6 x 1/16"	3
24	Washer, Nylon - #6 x .050"	1
25	Washer - #10 flat	2
26	Lockwasher - #2	2
27	Nut - 2-56	2
28	Nut - 6-32 KEPS	8
28	Nut - 10-32 KEPS	1
29	Nut - 10-32 Wingnut	1
30	#10 solder lug	1
31	RF connector - female PCB-mount	2
32	Angle bracket, 6-32	4
33	Fan - 12V 60x60x25mm	1
33	Fan - 12V 40x40x20mm	2
34	Hole plug - Nylon, 1/4"	2
34	Hole plug - Nylon, 1/2"	1

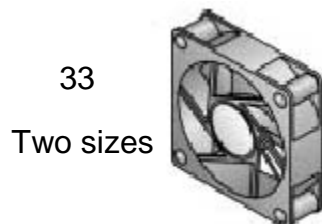
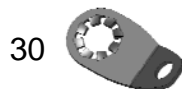



Item	Description	Qty
35	Meter mount - plastic	1
36	Front plastic shroud	1
37	Bottom cover plate	1
38	Chassis bottom	1
39	Front Panel	1
40	Large Bracket Front	1
41	Large Bracket Right/Left	2
42	Small bracket	1
43	Fan mounting plate	1
44	PC/MIO cover plate	1
45	Back Panel	1
46	Top Cover	1
47	RPG - Bourns ENA1J-B28-L00128	2
48	Speaker	2
49	Meter - Hoyt 811-T 100uA	1
50	Noritake 264x64 Graphics VFD	1
51	USB flash drive	1
52	Serial number sticker	1

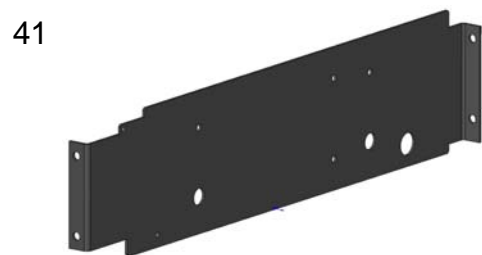
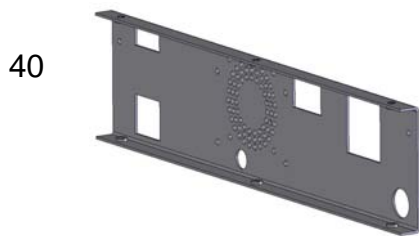
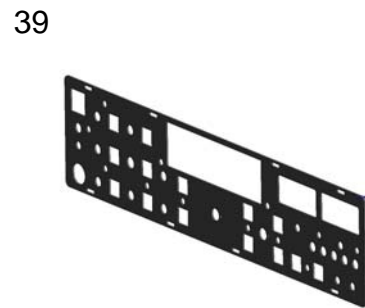
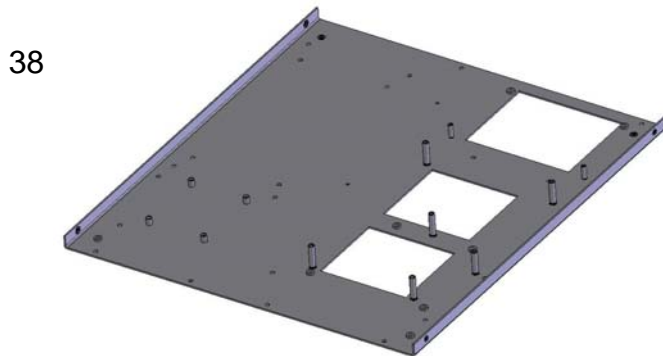
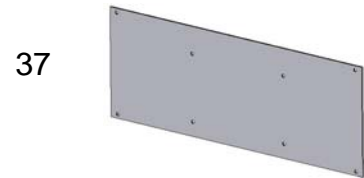
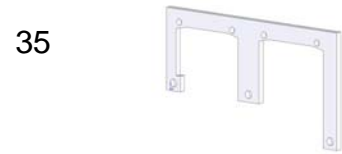

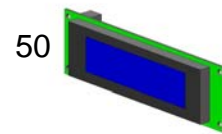
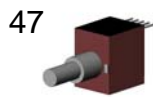
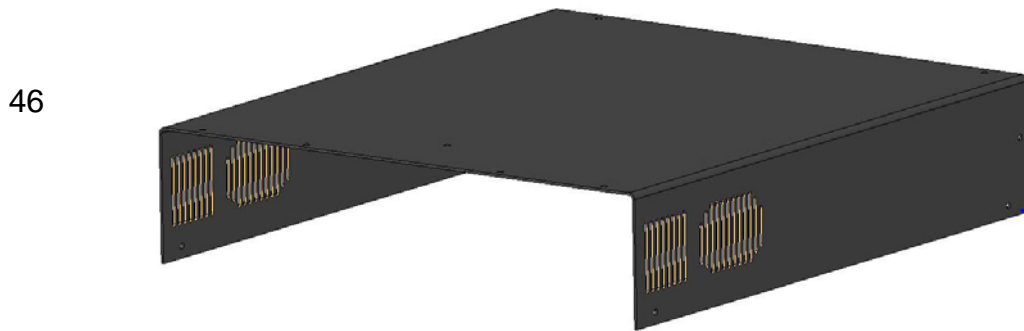
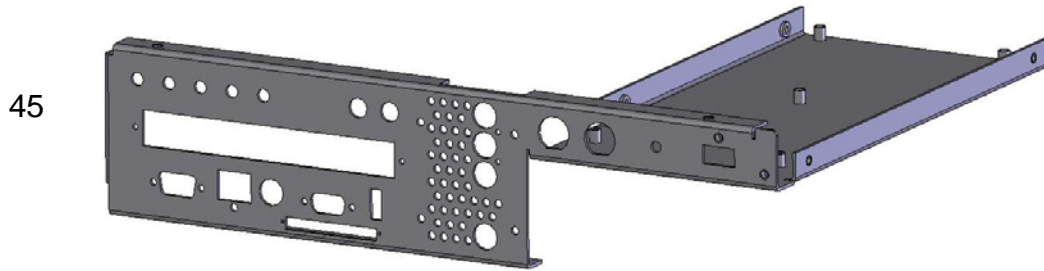
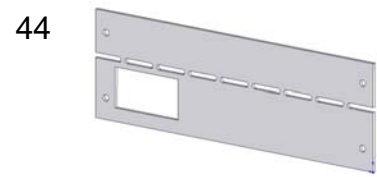
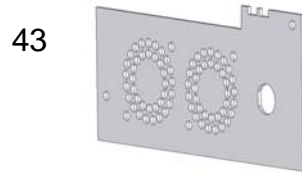

Style may vary

52





# Cables

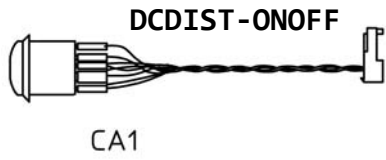

DC power input

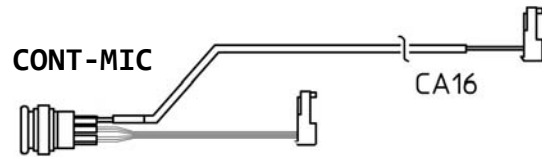
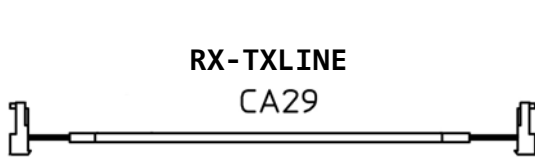

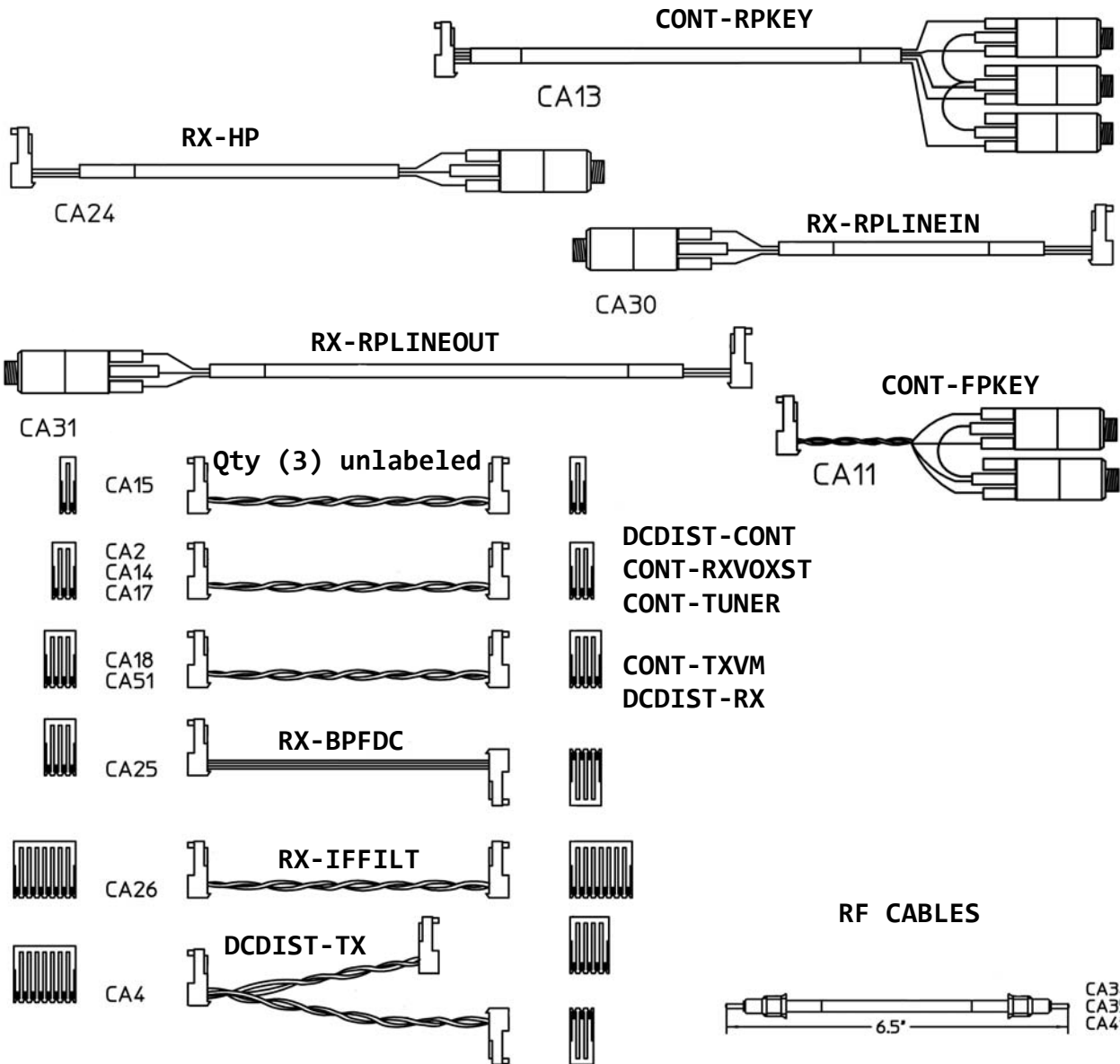

CA33	RXBPFMAIN-TX/AMP
CA34	RXANT
CA35	RF1 (RXBPF to RX)
CA36	RXLO1
CA37	RXLO4
CA38	TXBFO
CA39	RXLO2
CA40	RXLO3
CA41	IF1
CA42	IFOUT
CA43	IF4
CA44	TXVFO
CA45	IF2
CA46	IF3
CA47	TX-TUNER/AMP

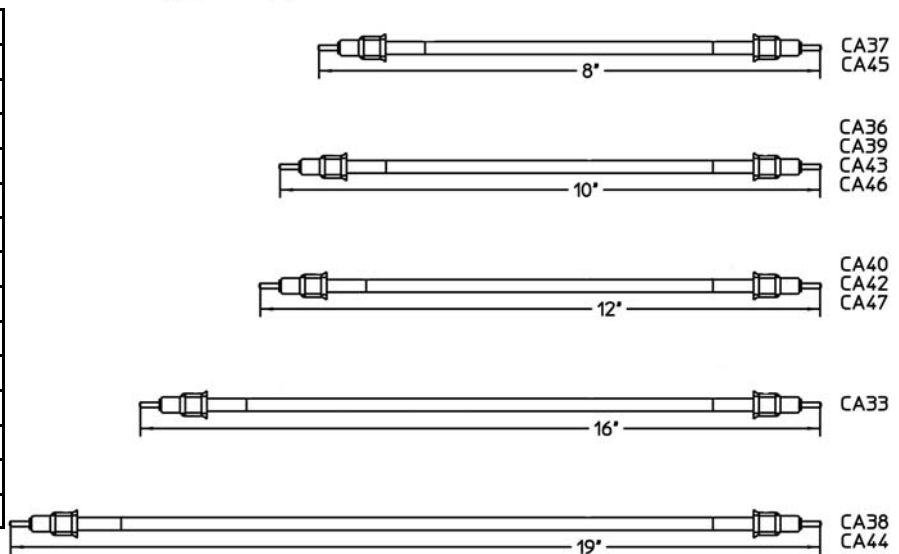



## STEP-BY-STEP ASSEMBLY: Chassis, DC Power

Refer to Pictorial 1 for the following steps.

- ( ) Place the chassis bottom on a hard surface. Push the 6" board guide into the holes in the center transmitter compartment until the guide is firmly seated. Use a small hammer if necessary, but be careful not to bend the sheet metal.
- ( ) Position the front bracket with the top and bottom lips facing you and the fan holes toward your left. Attach the fan to the back side of this bracket with two 6-32 x 1 1/4" screws and two 6-32 KEPS nuts. Use two holes diagonally opposite each other. Make sure the airflow arrow on the fan faces toward the back, with the power cable on the bottom. Holding the front bracket as described, the KEPS nuts should be visible to you and the screw heads should touch the fan.
- ( ) Locate the 4-pin to 12-pin PC power cable. Set the end with the 4-pin connector into the power compartment. Dress the cable horizontally from left to right and let the other end hang out past the right side of the chassis.
- ( ) Attach the front bracket to the chassis bottom using three 6-32 x 1/4" screws. As you position it, dress the PC power cable under the fan and make sure it is not pinched.
- ( ) Position a large bracket vertically such that the long side is perpendicular to the front of the radio and the lips face to the right. Attach this bracket to the front bracket using two 6-32 x 1/4" screws.
- ( ) Position the other large bracket with its back lip pointed left. Attach it to the front bracket using two 6-32 x 1/4" screws, dressing the PC power cable along the right side of the large bracket and into the PC compartment.
- ( ) If you plan to install a 2.5" laptop hard drive (not included) internally, attach it to the back-facing side of the small bracket using four M3 x 5mm screws (not included).
- ( ) Attach the small bracket to the right large bracket using four 6-32 x 1/4" screws. The lips on the small bracket face toward the back.

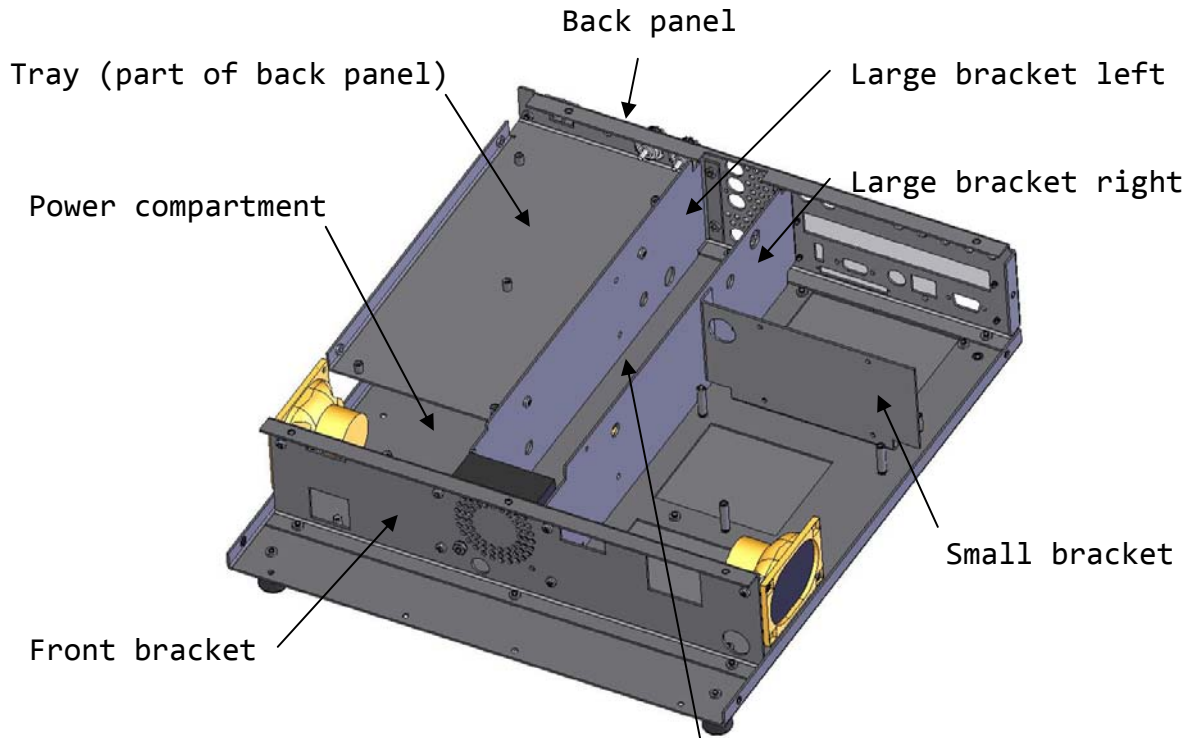

Attach 6" board guide in center of transmitter compartment

Pictorial 1

4-40 x 1/4" screw, shoulder washer, T0-220 part

Thermasil™ insulator

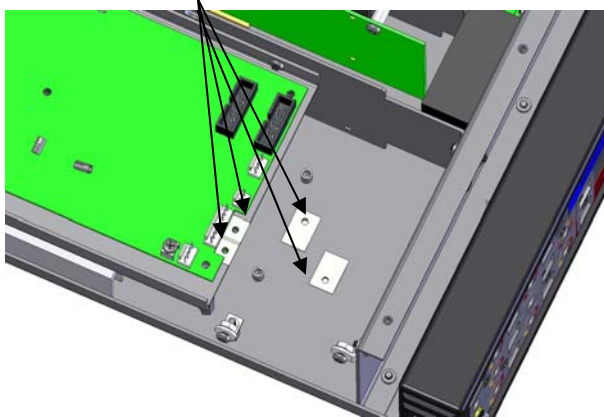

Pictorial 1A

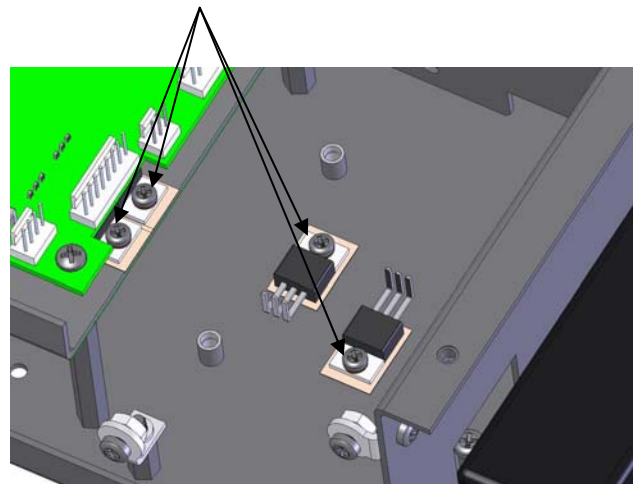

Pictorial 1B



If you have purchased the internal PC (Option 105):

- ( ) Unpack Option 105 and do a parts inventory.
- ( ) Build the PCPS board (See Appendix A).
- ( ) Place two TO-220 Thermasil™ insulators on the bottom chassis as shown in Pictorial 1A.
- ( ) Bend the leads of PCPS part Q1 up .8" from the top of the tab.
- ( ) Attach Q1 to the chassis using a 4-40 x 1/4" screw and a #4 shoulder washer as shown in Pictorial 1B.
- ( ) Repeat the previous two steps for PCPS part U2.
- ( ) Using an ohmmeter, verify that there is >10K ohms resistance from the tab to the chassis. If either tab is shorted, try again.
- ( ) Carefully and gently lower the PCPS board onto the 3-pins of Q1 and U2. Attach the PCPS board to the bottom chassis using four 6-32 x 1/4" screws.
- ( ) Solder all three pins of U2 and Q1. Clip the leads, mak-

ing sure that the clippings do not fly into the chassis.

- ( ) Connect the 4-pin connector to the cable that was placed in this compartment in an earlier step.
- ( ) Unpack the PC. Be sure to observe handling precautions to avoid static discharge which could damage this board. Remove the 2 jackscrews on each of the DB connectors (VGA and RS-232C) and discard them.
- ( ) Remove the Compact Flash card (CF) from the bottom of the PC and put it in a safe place. Using a fine-tipped awl, remove the metal CF ejection mechanism (with plastic lever) by carefully prying it off. It is easiest to do this on the two latches on the side closest to the edge of the board. Discard this cover.

---

If you have purchased the MIO-6254 board:

- ( ) Remove jumper J7 in the corner of the PC as shown in Pictorial 2. Leave the jumper in place on J1.
- ( ) Unpack the MIO-6254 box. Remove the 4-40 x 3/4" brass spacers and 4-40 nuts from the bag and attach them to



Remove this CF  
ejection mechanism  
from the PC by pry-  
ing here

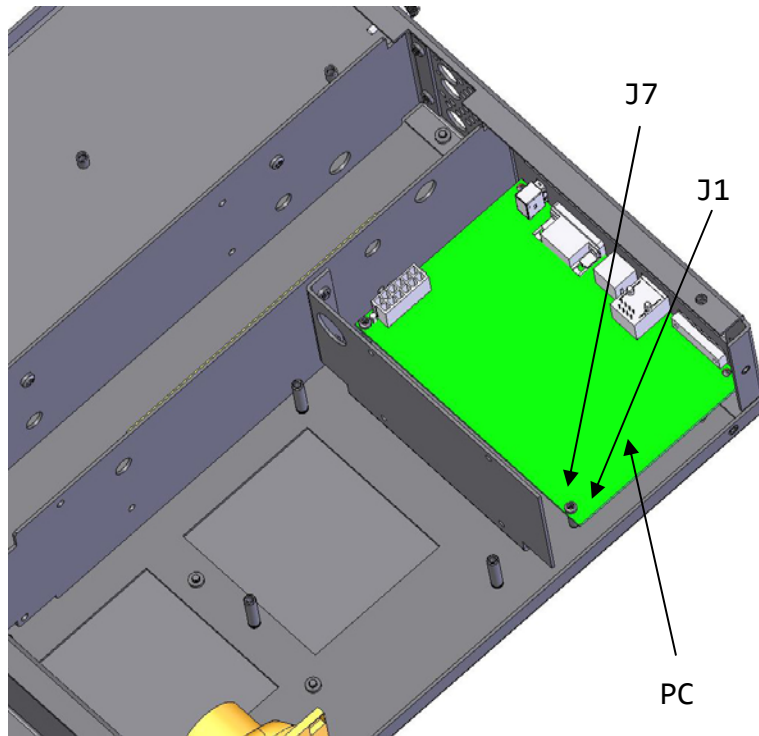
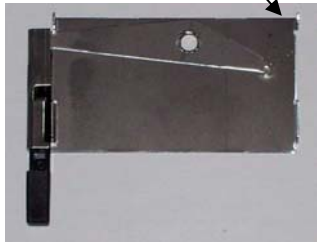

Attach 4 brass spacers, nuts and screws to PC/MIO

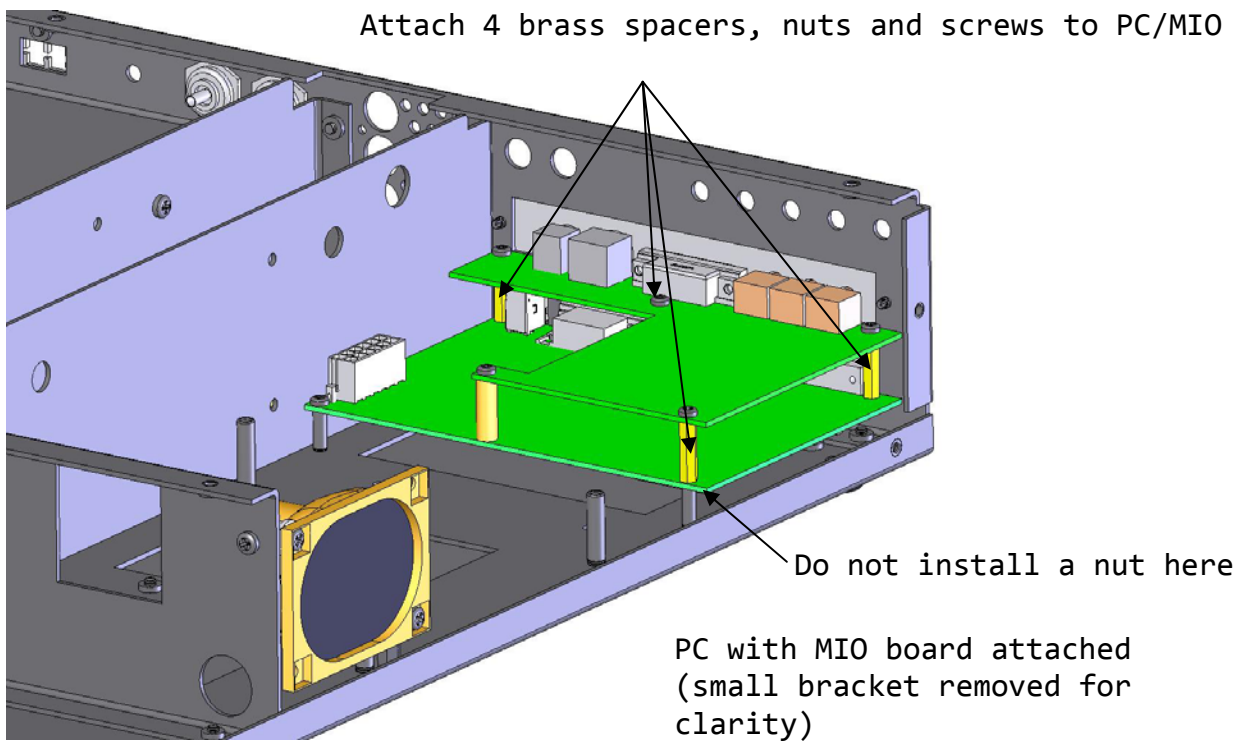

Pictorial 2



four locations on the PC as shown in Pictorial 2. Tighten the nuts securely on the bottom of the PC except where noted.

- ( ) Carefully push the MIO board onto the PC, making sure to align the row of connectors and mounting holes to that of the PC. Affix it to the PC with the 5 screws that are provided in the bag that is included with the MIO board.
- ( ) Align the board(s) so that the row of connectors is toward the back.
- ( ) Place the PC assembly over the two standoffs that are located in front of the large opening in the bottom chassis. If you do not have the MIO board, secure the PC in the standoffs with two 4-40 x 1/4" screws. If you do have the MIO board attached, loosen the right front corner screw, tighten the spacer in-between the two boards into the chassis-mounted standoff and then re-tighten the screw on the top. The PC assembly is held in place weakly until it is mounted to the back panel in a later step, so do not apply excessive force to it.
- ( ) ***Do not connect the power cable to the PC at this time.***

---

Refer to Pictorial 3 for the following steps.

- ( ) Attach two S0-239 connectors to the large "D"-shaped holes on the back panel. The lock-washer and nut go on the *outside* of the panel (the side with lettering).
- ( ) Attach the ground lug to the hole next to the S0-239 connectors: Place a #10 solder lug on the 10-32 screw and then insert it into the back panel from inside, and secure it with a 10-32 KEPS nut on the outside. Position the solder lug so that it faces the S0-239 connectors. Place two #10 washers over the screw and then fasten the #10 wingnut finger-tight.
- ( ) Attach the back panel to the back of the chassis bottom using two 6-32 x 1/4" screws on the bottom and two more on the right bracket. Use only one 6-32 x 1/4" screw on the top of the two left bracket holes. If you have installed the PC, align the PC's connectors to the holes in the back panel as you attach the back panel to the chassis.
- ( ) Attach the tray portion of the back panel to the left large bracket using two 6-32 x 1/4" screws. Holes are lo-



PC/MIO cover. If you have the PC but not the MIO, snap the bottom half of this bracket off at the breakaway tabs.

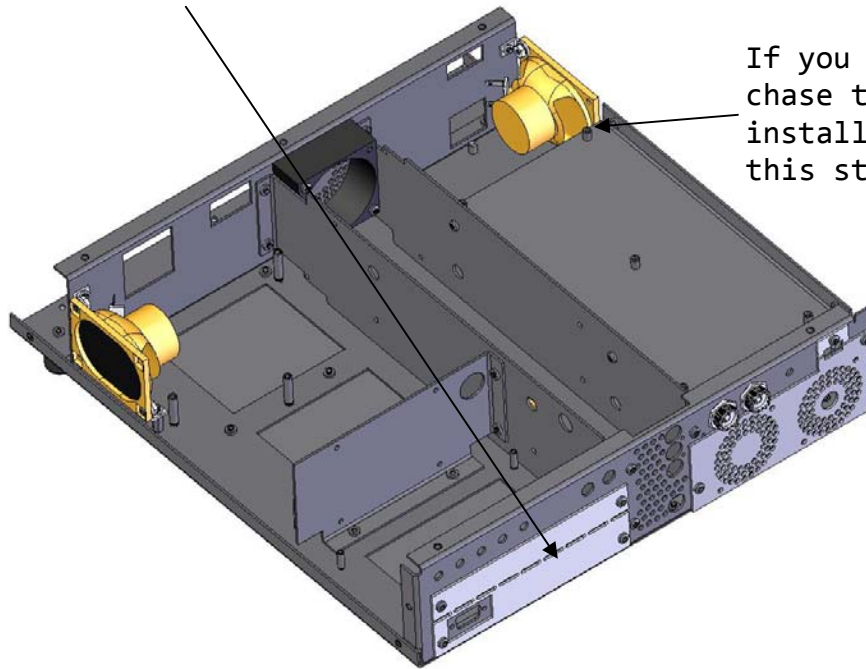

If you did not purchase the 100W PA, install spacer below this standoff.

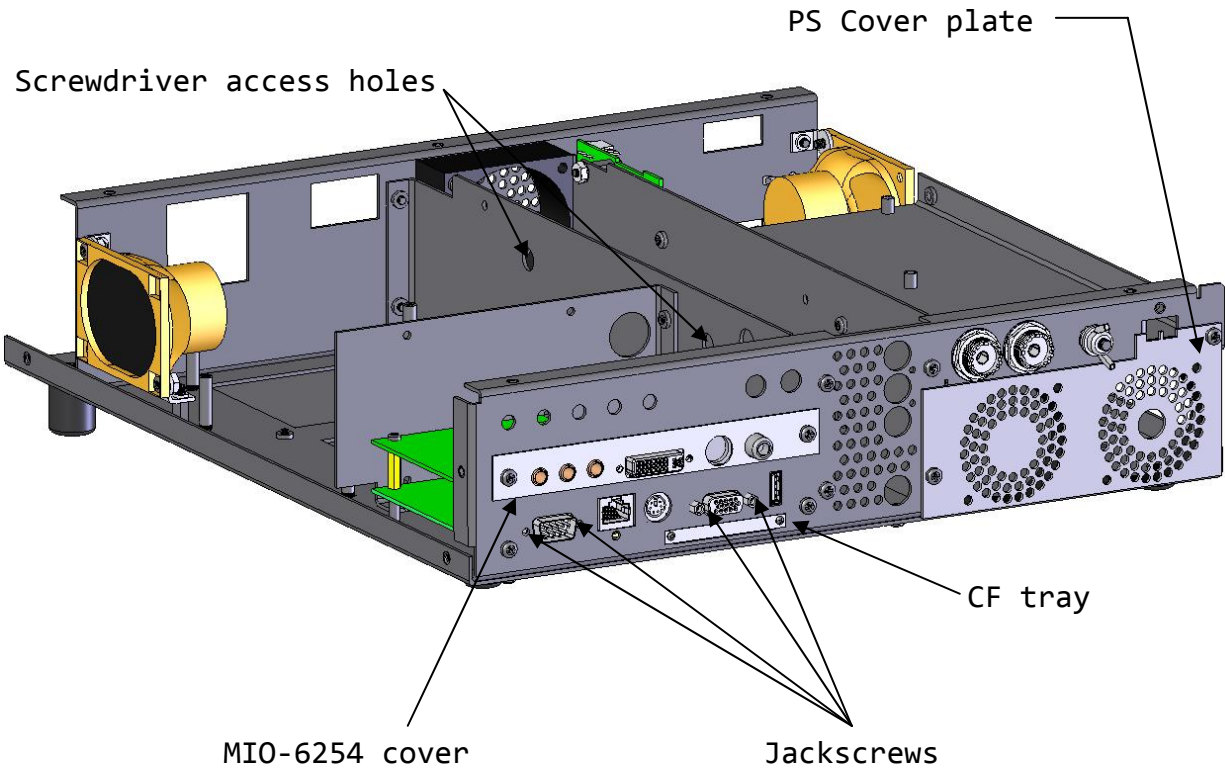

Pictorial 3



cated in the right large bracket for screwdriver access.

---

**If you have installed the PC:**

- ( ) Affix two brass jackscrews to both DB connectors to fasten the PC securely to the back panel.
- ( ) Insert the CF card into the CF tray with the serial number sticker facing up, and insert the tray into the PC from the back panel. Affix the CF tray to the back panel using two #1 x 1/4" self-tapping screws.
- ( ) If you did NOT install the MIO card, break the PC/MIO cover apart at the breakaway tabs and fasten the smaller piece to the back panel using two #6 x 1/4" self-tapping screws.
- ( ) If you did install the MIO board, fasten the MIO-6254 cover (with holes and silk-screening) to the back panel using two #6 x 1/4" self-tapping screws.

---

**If you did not install the PC:**

- ( ) Build the RS232 Board (see Appendix B). Remove the two jackscrews from the 9-pin connector and insert the con-

necter into the hole on the back panel labeled "RS-232C". Secure it using two 4-40 x 3/16" x 5/16" jackscrews (with Chassis HW).

- ( ) Fasten the PC/MIO cover bracket to the back panel using four #6 x 1/4" self-tapping screws.

- 
- ( ) Attach two 40x20mm DC fans to the inside of the PS Cover using four 6-32 x 1" screws on the outside and four 6-32 KEPs nuts on the inside. Be sure the arrow that is embossed on one side of each fan points toward the back (exhausting out the back of the radio). Position the wires so that they exit out the bottom of the fan.
  - ( ) Clip the white wire on both fans close to the body of the fan. Be careful not to nick the other wires.
  - ( ) Cut the red and black fan wires 3" from the body of the fan. Strip the leads to 1/4" and tin them.

- ( ) Locate a 2-pin MTA cable (CA15). Cut it 3" from the connector on each end, making two 3" long cables. Strip the wires to 1/4" and tin them. Place 1/2" of heatshrink tub-



ing on each wire, then solder the red wire to a red fan wire and the black wire to the black fan wire of the same fan. The overall length of the cable from the fan to the connector should be 6". Slide the heatshrink tubing over the solder joints and heat them with a heat gun or soldering iron until the tubing has shrunk around the contacts. No bare wires should be exposed.

- ( ) Repeat the previous procedure for the second fan.
- ( ) Insert the fan cables through the hole in the back panel tray and up into top compartment.

---

If you purchased the 100W PA:

- ( ) Attach a fuseholder to the PS cover using the provided plastic nut. The rubber washer goes on the outside of the back panel. Tighten it securely.
- ( ) Insert a 25A 3AG fuse into the fuseholder and attach the cap.

- 
- ( ) Attach the PS cover plate to the back panel using two 6-32 x 1/4" screws.

*Note: If you did not purchase the 100W PA, you can place a battery inside and bring its power cable out the fuse hole. A 1/2" hole plug is provided to cover this hole if you do not plan to use a battery.*

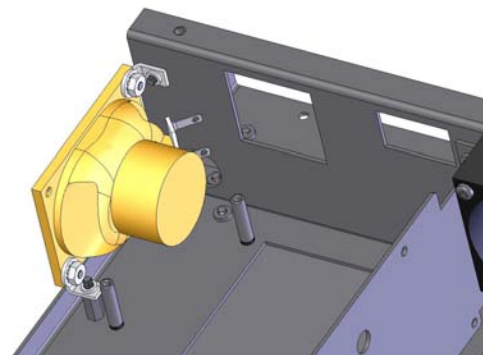

Detail 3. Speaker mounting

- ( ) Attach each speaker to the chassis bottom and front bracket using two angle brackets, one 6-32 x 1/2" hex male/female spacer, two 6-32 KEPS nuts and four 6-32 x 1/4" screws. See detail 3.
- ( ) Build the DC distribution section of the DCD/Tuner Board (See Appendix C).
- ( ) If you have purchased the Tuner option, build the Tuner section of the DCD/Tuner Board (See Appendix D). *Note: If you want to add the tuner later, skip this step.*
- ( ) Attach two T0-220 sticky-back insulators to the tray on the



two holes near the front edge. Be sure to uncover the hole in the insulators and line the holes on the chassis up with the openings in the insulators. See Pictorial 1A.

- ( ) Attach the DCD/Tuner board to the tray using four 6-32 x 1/4" screws in three corners and the center. Do not put a screw in the hole closest to the front left side (see note on Pictorial 3). If necessary, pry the Anderson Powerpole connectors up slightly so that they engage in the center tab in the PS cover.
- ( ) If you have not purchased the 100W PA, attach a 6-32 x 2" hex female/female spacer below the corner standoff on the tray. Place a .05" Nylon washer between the top of the spacer and the bottom of the tray and secure the spacer with a 6-32 x 1/2" screw, tightening both the screw and the standoff.
- ( ) Attach the Anderson Powerpole clamp to the back panel using one 6-32 x 1/4" screw. Insert the small tab in the opening between the red and black connectors.
- ( ) Apply heat to the pin you soldered earlier on U8 and push it down flush with the chassis. Move it back and forth until the hole in the tab lines up precisely with the hole in the chassis. Be careful not to let the soldering iron touch the connectors that are nearby.
- ( ) Insert a #4 shoulder washer in the tab hole, then insert a 4-40 x 1/4" screw through the washer and tab. Attach the screw to the bottom of the tray with a 4-40 KEPS nut.
- ( ) Repeat the previous two steps for transistor Q1. Since Q1 and U8 look alike, make sure you put the right part in the right location.
- ( ) Solder all 3 pins of Q1 and U8. Clip the leads, making sure that clippings do not fly into the chassis. Be careful not to let the soldering iron touch the plastic connectors that are nearby.
- ( ) Using an ohmmeter, verify that the resistance from each tab (U8, Q1) to ground is greater than 1K ohms. If you read a short to ground, remove the screws, reposition the parts and try again.
- ( ) Connect the fans to the two connectors labeled "Fans" at the back end of the DCD/Tuner board.



- ( ) Locate CA1, the on/off switch with attached cable. Attach the 5-pin connector to J4 on the DCD/Tuner board. Let the other end hang loose, but be careful not to short it to the chassis.

***NOTE: The switch serves as an inhibit, not a true on/off. If you remove the IDC connector from the DCD/Tuner board while DC power is applied to the unit, the unit will power-up. Be careful!***

- ( ) Solder one pin of a gas discharge tube and a 1.5" length of bare wire to each S0-239 antenna connector's center terminal. Connect the other end of each tube to the #10 solder lug as shown in Detail 5 below. Dress the parts neatly along the chassis and be careful they do not short to each other.



Detail 5. Gas discharge tubes

- ( ) Solder the bare wire going to antenna A to the corresponding pin on the DCD board. Do the same for antenna B.



## STEP-BY-STEP ASSEMBLY - Initial Tests

- ( ) Locate the pre-assembled Anderson Powerpole cable in the Cable bag. Attach it to the connectors on the back panel and connect the other end to a DC power supply that is capable of delivering 4A at 11-15VDC (12-15VDC if the PC is installed).

Power should come back on once the voltage reaches about 10.8V and the light should turn green once it reaches 11.9V. If this does not happen, refer to the troubleshooting guide in the Service Manual.
- ( ) Apply 12VDC power to the rig. Push the on/off switch. The green LED inside the on/off switch should light and the small fans should run at a low speed with air moving from front to back. Remove power immediately if you smell smoke or see anything wrong.
- ( ) Using a voltmeter, verify that you can measure the applied voltage between the screw terminal near the front of the DCD/Tuner board and chassis ground.
- ( ) Using a voltmeter, measure the voltages on J10 (Rx) of the DCD/Tuner board. They should agree with the voltages in Table 1. If you do not read any voltages, refer to the troubleshooting guide in the Service Manual.
- ( ) Slowly lower the input voltage. As it reaches about 11.5V, the on/off switch should turn red. Below about 9.7V it should go off. Now slowly raise the voltage.
- ( ) Push the on/off switch to the off position and verify that the power LED goes off.
- ( ) If you have installed the PC option, locate the 4-pin IDC cable that came with that kit and insert one end into the 4-pin connector marked J1 (PC P/S) on the DCD/Tuner board. Insert the other end into the 4-pin connector on the PC power supply board (PCPS). Plug the white 12-pin connector that is located in the PC compartment into the PC power jack.
- ( ) If you have installed the PC option, connect a VGA cable, keyboard and mouse to the back of the unit. Apply power and push the on/off switch. You should hear the PC beep and begin its boot procedure. If you want to experiment with the PC for a while, feel free! You've earned some relaxation time. If all is well, push the power switch to off and remove the DC input. Otherwise refer to the troubleshooting guide in the Service Manual.



Connector.pin	Voltage
J10.1	5.0V +/- .15V
J10.2	-9.5V +/- .5V
J10.3, J10.5	0.0V +/- .05V (ground)
J10.4	Applied voltage (11-15V)

Table 1. DC Voltages on DCD/Tuner board



## STEP-BY-STEP ASSEMBLY-Meter Preparation

Refer to Detail 6 for the following steps.

Note: If you purchased the 2nd meter option, prepare both meters at this time.

( ) Using scissors, carefully cut out the DZ meter face(s).

*Handle with care to avoid getting finger oils on the meter faces. Use a dry cloth to hold the meter faces.*

If you have only one meter, use the face that has an S-meter on top, a "REL" (relative) scale in the middle, and an ALC scale on the bottom. If you have two meters, use the other two meter faces.

( ) Pop the cover(s) off the meter(s) by carefully twisting a medium flat blade screwdriver in the notch on one side. Unscrew the two screws holding the 100uA meter face to the plastic (only a couple of turns - you do not need to remove the screws) and remove the meter face(s), being *extremely careful* not to hit or bend the red needle(s).

( ) Insert the new meter face(s) in place of the old one(s) and tighten the screws gently. Do not over tighten these screws to avoid causing any bowing or dimpling in the face(s). Make certain the face(s) are inserted all the way and that no edges extend

out where the meter cover will touch them.

( ) Carefully snap the meter cover(s) back on. If a face bows, repeat this process, trimming any excess off the meter face.

( ) Set the meter(s) aside. Be sure to protect the meter face(s) from scratches.

( ) A 9" cable with unterminated ends is included in the 2nd meter option. Set it aside. It will be used later.

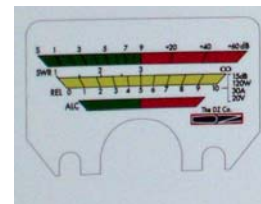

Single meter face

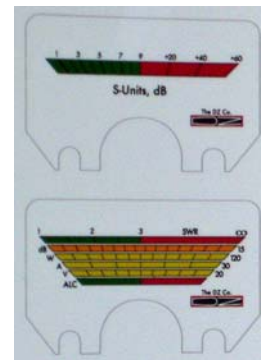

Dual meter faces

Detail 6.





## STEP-BY-STEP ASSEMBLY-Front Panel Integration

- ( ) Build the Front Panel board (See Appendix E).

Refer to Pictorial 4 for the following steps.

- ( ) Place the front panel sheet metal upside down on a towel or other smooth surface. Now place the Vacuum Fluorescent Display (VFD) over the large rectangular opening with the glass facing down and connectors to the right. Line up the two bottom mounting holes with the two short captive standoffs on the sheet metal. Insert two 6-32 x 1/2" hex male/female standoffs in the bottom two holes, with the threads going into the standoffs on the sheet metal.
- ( ) Attach two 6-32 x 1/2" hex male/female standoffs to the top two VFD mounting holes and secure with 6-32 KEPS nuts located between the VFD and the sheet metal.
- ( ) Push the front panel board onto the back of the steel front panel. Attach it with two 6-32 x 7/16" hex male/female standoffs (on the two holes on the far right side that are vertical to each other), and five 6-32 x 1/4" screws as shown in Pictorial 4.
- ( ) Push the meter(s) into the back of the steel front panel (meter faces visible from the front). Put the S-meter closest to the side of the sheet metal (left side as viewed from the back) and the transmit meter (if present) toward the inside (right side as viewed from the back). Handle the front panel sheet metal by the edges to avoid getting oil from your fingers on it.
- ( ) Using a small Phillips head screwdriver, remove both screws holding the small circuit board on the back of the meter(s). Using wire-cutters, clip the upper right and left corners of this board. This provides clearance for the Lucite meter mount that will be installed over the meters in the next step. Replace the screws and tighten them snugly.
- ( ) Remove the stickers from both sides of the Lucite meter mount. Lay it over the meters with the long leg to your right. Attach the meter mount to the meters using four 6-32 x 1/4" thread-cutting screws. Do not over-tighten, as you may strip the threads in the soft plastic. If the meter mount does not lie flat, repeat the previous step.

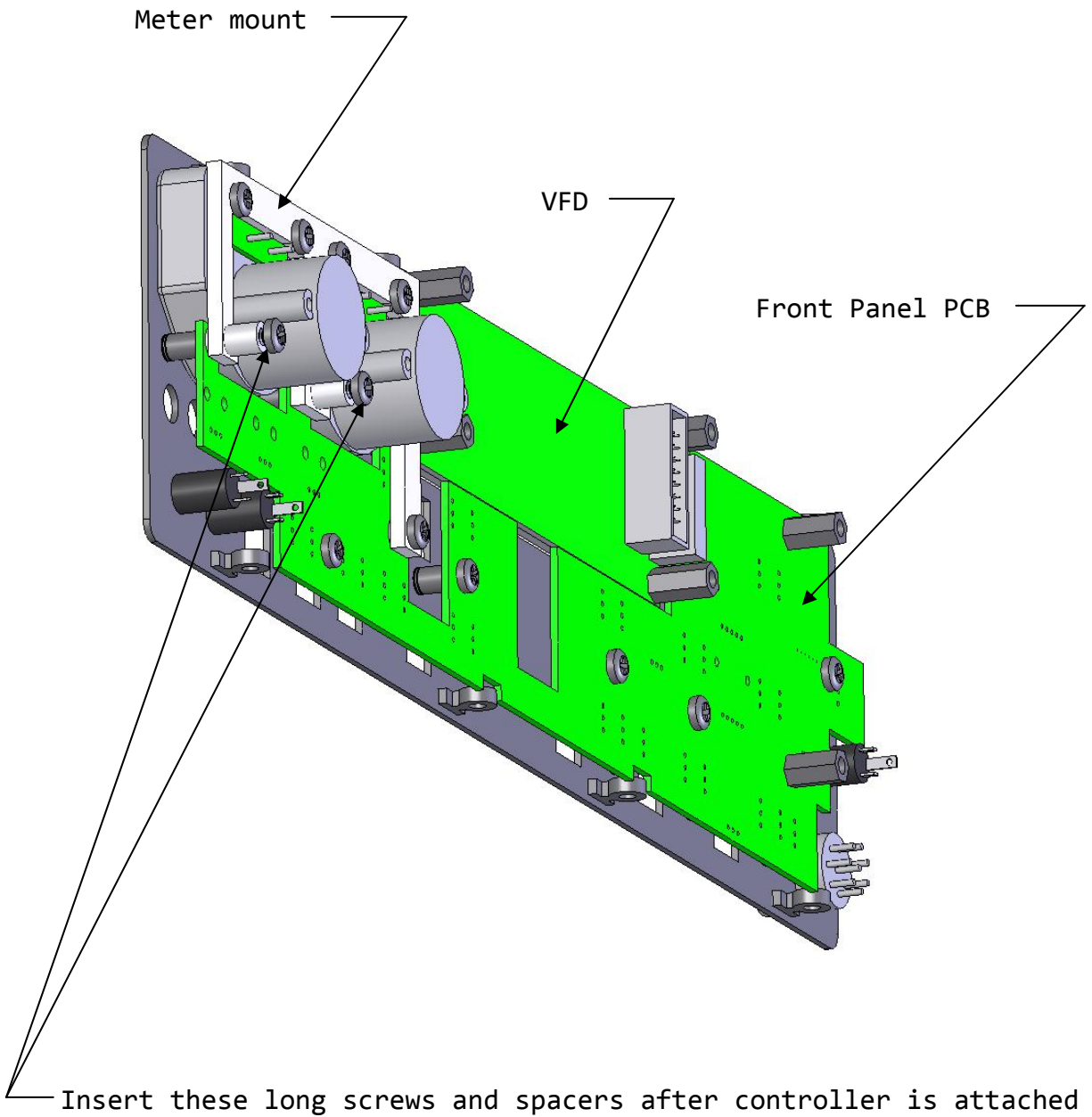

Pictorial 4

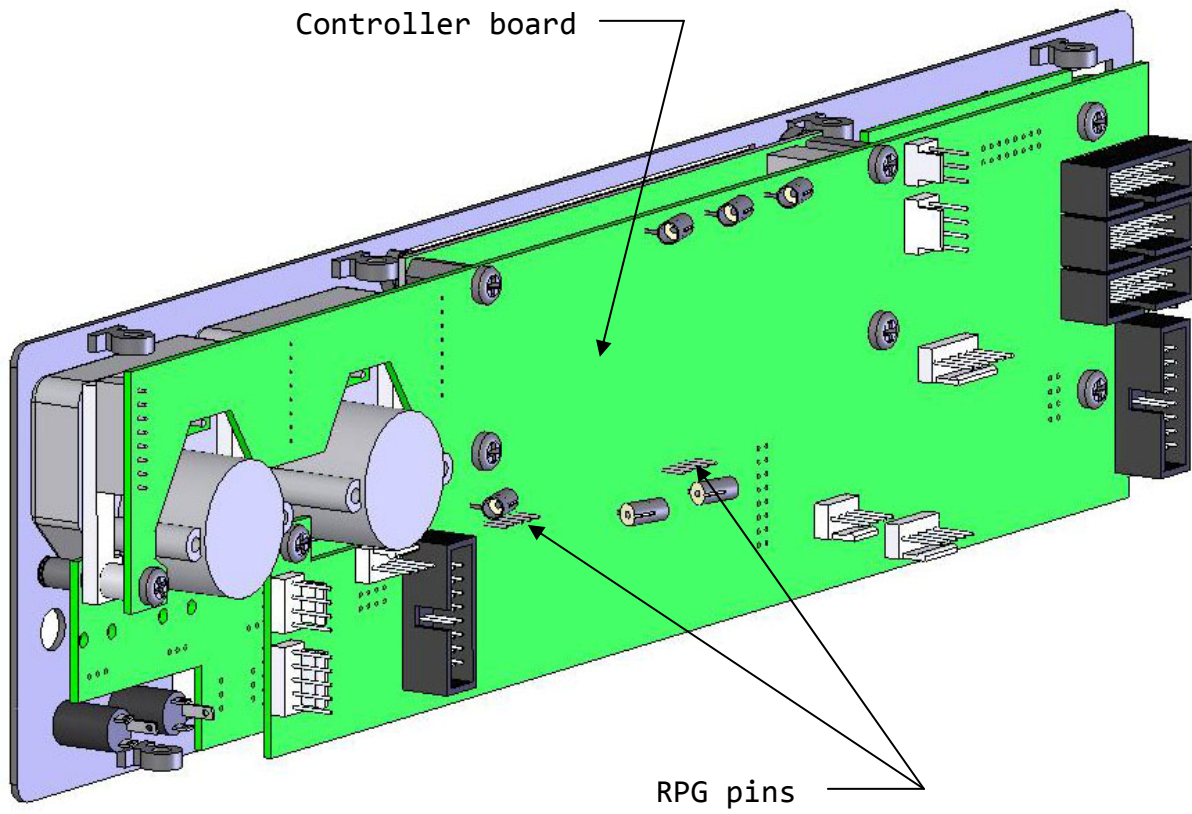

Pictorial 5



- ( ) Use a 6-32 x 1/2" screw and 1/16" nylon spacer to hold the long leg of the E-shaped meter mount bracket to the front panel board. Leave the other two holes under the meter mount bracket open for now.
- ( ) Attach the two large rubber feet to the bottom of the chassis towards the front using two 6-32 x 7/8" screws. Attach the two small rubber feet to the two holes on the back, directly opposite the front feet, using two 6-32 x 1/4" screws.

*For the following steps, be sure that you are properly grounded and working on a static-free work surface. Static can damage the sensitive control board. Refer to Pictorial 5.*

- ( ) Remove the controller board from its bag. Orient it with the LED bars to the right and the silkscreened lettering side of the board to the back.
- ( ) Locate the two Rotary Pulse Generators (RPG). Remove the nuts and lockwashers from their shafts and save them for use in a later step.
- ( ) Place both RPGs flush with the front (non-silkscreened) side of the controller board such that the pins are toward the top of the board and the bodies of the RPGs point down. Solder ONLY one pin on each of the two RPGs to the controller board, using solder sparingly. Right now, you only want to keep them from falling out while you install the controller. You'll be heating this pin up and soldering the others in a subsequent step.
- ( ) Attach the controller board to the front panel assembly. A fair amount of pressure is required to align the five connectors (four to the front panel and one to the display) while pushing the RPG shafts through their openings. Push and wiggle the board gently but firmly until all connectors are lined up. The board may flex a little during this process. Once snug, tighten the controller to the front panel and display using six 6-32 x 1/4" screws. Do not attach anything to the remaining two meter mount holes in this step.
- ( ) While holding the threaded part of one RPG shaft, heat up the solder on the one pin you soldered earlier. Pull the RPG towards the front panel until it is flush with the front panel sheet metal.



Now solder all 5 pins of the RPG to the controller. Repeat for the other RPG. Do *not* fasten the nut or lockwasher to the front panel at this time.

- ( ) Using a small screwdriver, pencil or other tool, carefully insert a 1/16" nylon washer under one of the two remaining holes, between the meter mount and the front panel. Insert a #6 x 9/32" unthreaded spacer between the front panel and controller board. Finally, insert a 6-32 x 3/4" screw through the controller, spacer, front panel board, washer and into the metal standoff on the front panel sheet metal. Repeat for the other hole.
  - ( ) Using a small flat blade screwdriver, adjust the black meter zeroing screws on the front panel so that the meters read 0. These are not accessible after the next step, so make sure to do this step as accurately as you can.
  - ( ) Clean any oil residue off the front panel sheet metal with a tissue or clean, dry towel. Remove the backing from the front panel Lexan® overlay and attach it to the front panel sheet metal, aligning it carefully before pressing
- hard to stick it to the sheet metal.
- ( ) Temporarily attach the front panel assembly to the chassis bottom using two 6-32 x 1/4" screws. (Four are used when assembly is complete - these just hold it down while you work on other things.)
  - ( ) Attach the RPG nuts and lockwashers to the two RPGs and tighten. Do not over-tighten to avoid dimpling or cracking the overlay.
  - ( ) Make sure that no DC power is applied to the DC input connectors on the back panel.
  - ( ) Unplug the 5-pin on/off switch cable from the DCD/Tuner board. Insert this cable assembly through the square opening in the upper left of the front panel assembly, IDC connector first. Finally, push the on/off switch into the hole until it snaps into place. Insert the IDC connector through the rectangular opening in the front bracket and push it onto connector J12 (on/off) on the DCD/Tuner board.
  - ( ) Remove the knurled nuts from the minijacks on the CONT-FPKEY (CA11) cable. Insert the minijacks into the front panel with the minijack hav-



Pictorial 6. Completed unit showing cable dress from controller



ing all three pins connected into the hole marked **Paddles** and the other one into the hole marked **Manual**. Fasten the knurled nuts tightly against the front panel. Do not overtighten to avoid dimpling the polycarbonate overlay.

- ( ) Connect the other end of CA11 to J32 on the controller board.
- ( ) Locate a 3-pin IDC cable (CONT-TUNER – CA17) and connect one end to J21 (Tuner) on the controller board and the other to J3 (SWR) on the DCD/Tuner board. Dress this cable through the same opening as the previous cable (CA15).
- ( ) Locate a 15” 2-wire IDC cable assembly (CA15). Cut the cable so that one side is 9” in length. Save the 6” half for use later. Strip 3/8” of insulation off the ends and tin them. Solder the black wire to negative (-) and the red wire to positive (+) on the S-meter. Run the other end of this cable through the large rectangular hole on the right of the front bracket and into the Receiver compartment. If not twisted, twist the cable approximately 2 turns per inch.
- ( ) If you installed the 2nd meter option, repeat the previous step using the CA15 cable provided with that option and solder the ends to the transmit meter.
- ( ) Locate the 6” half of the CA15 cable that you cut earlier. Strip the leads to 1/4” and tin them. Cut the red and blue fan wires on the large center-mounted fan 3” from the body of the fan. Strip the leads to 1/4” and tin them. Place 1/2” of heatshrink tubing over the ends. Solder the red wire from CA15 to the red wire of the fan. Solder the black wire of CA15 to the blue wire on the fan. Place the heatshrink tubing over the solder joints and apply heat until the tubing shrinks. Leave this cable in the transmitter compartment.
- ( ) Locate a 2-pin MTA cable (CA15). Cut it 3” from the connector on each end, making two 3” long cables. Strip the wires to 1/4” and tin them. Place 1/2” of heatshrink tubing on each wire, then solder the red wire to a red fan wire and the black wire to the black fan wire of the same fan. The overall length of the cable from the fan to the connector should be 6”. Slide the heatshrink tubing over the solder joints and heat them with a heat gun or



soldering iron until the tubing has shrunk around the contacts. No bare wires should be exposed.

- ( ) Locate the 16" 4-pin IDC cable (CONT-TXVM – CA18). Connect one end to J7 on the controller board. Pass the other end through the round hole under the fan in the front bracket and into the Transmitter compartment.
- ( ) Locate the 15" triple stereo minijack to 5-pin IDC cable (CONT-RPKEY – CA13). Pass the 5-pin IDC through the round hole at the bottom right side of the front bracket and connect it to J3 on the controller board. Run the cable along the bottom of the chassis and under the bottom right side of the small bracket. Remove the three knurled nuts and save them. Insert the one with only two wires going to it in the far right hole labeled **Keypad** on the back panel. Reattach the nut and tighten using the provided tool. Attach the other two minijacks in similar fashion. The minijack that has one wire going to two pins goes to the hole labeled **Manual** in the "Key" group. The other one goes to the hole labeled **Paddles**.
- ( ) Locate a 6 1/2" 4-pin IDC cable (CONT-RXVOXST – CA14).

Connect one end to J11 (ST/VOX, right below the meters) on the Controller board. Dress the cable through the small rectangular opening on the right side of the front bracket.

*The next 6 steps are the first of several in which you will connect RF cables. These connectors can be a little tricky to insert into the mating connectors on the PC boards, and they can work loose if inserted and removed more than about 10 times. They have a friction fit and must be aligned perfectly to go in. Once aligned properly, a gentle but firm push will seat them. Often, using your fingernails on the "ears" of each cable's connector will help you push them in. Be sure that any strands at the end of the center conductor of the cables are either clipped or lined up with the centerline to avoid difficulty getting the center pin into the mating hole. Once you get the first one in properly, the rest will be easier.*

- ( ) Insert RF cable RXL01 into J24 (RXL01) on the Controller board. Dress the cable through the large rectangular hole on the right side of the front bracket.
- ( ) Insert RF cable RXL02 into J25 (RXL02) on the Controller board. Dress the cable through the large rectangular



hole on the right side of the front bracket.

- ( ) Insert RF cable RXLO3 into J26 (RXLO3) on the Controller board. Dress the cable through the large rectangular hole on the right side of the front bracket.
- ( ) Insert RF cable RXLO4 into J23 (RXLO4) on the Controller board. Dress the cable through the SMALL rectangular hole on the right side of the front bracket.
- ( ) Insert RF cable TXVFO into J22 (TxVFO) on the controller board. Insert the other end through the round hole in the front bracket and into the transmitter compartment. Put electrical tape over the center conductor at the end of the cable so that it does not touch the chassis.
- ( ) Insert RF cable TXBFO into J27 (TXBFO) on the controller board. Insert the TXBFO cable through the round hole in the front bracket and into the transmitter compartment. Put electrical tape over the center conductor at the end of the cable so that it does not touch the chassis.
- ( ) Locate the 10" stereo minijack to 3-pin IDC connector (RX-HP – CA24). Remove the knurled nut and save it. Pass

the minijack through the front panel hole on the far left side with a headphone symbol next to it. Reattach the nut and tighten securely. Pass the IDC end through the small rectangular hole on the right side of the front bracket.

- ( ) Locate the 24" 6-pin IDC to rectangular connector labeled CONT-PCRS232 (CA12). Pass the IDC end from the receiver compartment through the round hole at the bottom right of the front bracket and connect it to J4 (RS232C) on the Controller board. Run the cable along the bottom of the chassis and under the bottom right side of the small bracket.
- ( ) Connect the rectangular connector at the other end of the CONT-PCRS232 cable (CA12) to CN8 on the PC (if installed) or to J1 on the small RS232 Board that you earlier attached to the back panel.
- ( ) Locate the 8-pin microphone connector to 6-pin IDC and 2-pin stereo cable (CONT-MIC – CA16). Insert the 6-pin IDC connector and stereo cable through the mic hole in the bottom left of the front panel. Tighten the nut on the back side of the panel. Attach the 6-pin connector to



J20 on the controller board. Pass the stereo cable through the hole below the fan in the front bracket and into the transmitter compartment.

- ( ) Insert the ends of an 8" gray ribbon cable (CONTDATA-TUNER/KEYER – CA22) into 16-pin connectors J14 and J28 of the controller board. This connects the Keyer microprocessor to the main microprocessor.
- ( ) Insert one end of an 8" gray ribbon cable (CONTDATA-TUNER/KEYER – CA22) into the bottom of three 16-pin connectors, J18, on the controller board. Dress the other end through the rectangular hole in the front bracket. Make two right-angle folds in the cable close to the DCD/Tuner board so that the cable enters the DCD/Tuner board lined up with connector J2 (the innermost of the two 16-pin connectors). Insert the other end of this cable into J2 on the DCD/Tuner board.
- ( ) Locate a 14.5" gray ribbon cable having one connector on one end and two on the other end (CONTDATA-RX-BPF – CA20). Push the end with one connector into the middle of three 16-pin connectors, J15, on the Controller board. Fold the cable at a right angle and dress the cable along the underside of the lip in the front bracket. Fold the other end at a right angle and position it in front of the large rectangular opening on the right side of the front bracket.
- ( ) Insert one end of a 20.5" gray ribbon cable (CONTDATA-TX – CA21) into the top of three 16-pin connectors, J18 (Tx), on the Controller board. Dress the other end through the rectangular hole in the front bracket. Fold the cable at a right angle close to the DCD/Tuner board. Fold it over 90 degrees downward into the transmitter compartment. Fold it again at right angles such that it runs along the middle of the left bracket toward the back.
- ( ) Locate a 10" 3-pin IDC cable (DCDIST-CONT – CA2). Connect one end to J9 (Control) on the DCD/Tuner board. Run the other end through the bottom rectangular hole on the left side of the front bracket and into the front panel compartment. Connect the other end to J1 on the controller board.



## STEP-BY-STEP ASSEMBLY-Front Panel/Controller Tests

- ( ) Disconnect the 3-pin power cable from the DCD/Tuner board (J9) that goes to the Controller board.
  - ( ) Measure the resistance between pin 1 and ground on the connector that is at the end of the cable. It should be >200 ohms. Also measure resistance between pin 3 and ground. It should be open (or very large, >1M). If you measure a short at either point, see the troubleshooting guide in the Service Manual.
  - ( ) Reconnect the Controller power cable and turn on the radio by applying DC power to the APP connectors on the back panel and pushing the on/off switch.
  - ( ) You should again hear the PC boot if it is installed. (If you do not wish to cycle power on the PC while testing other boards, simply remove the 4-pin cable going to the PCPS board.) The front panel pushbuttons should light up briefly and then go out. The VFD should come up with a default frequency of 14.00000 MHz.
  - ( ) Push all buttons one at a time and note the response. The green LEDs inside the buttons should light when you push the button. Turn the dials and pots to observe their responses. At this point, since you have not yet installed the receiver or transmitter, many of the front panel controls will not seem to do anything. That's OK. As long as it lights up and some buttons respond, you can be sure that the controller and front panel boards are working.
- Note: There are only two user-changeable items on the Controller: the TCXO adjustment pot and a 5V/8V jumper for the microphone. These will be set later during receiver and transmitter calibration and testing.*
- ( ) Turn off the power and remove the DC inputs.





## STEP-BY-STEP ASSEMBLY-Receiver Integration

Refer to Pictorial 7 for the following steps.

- ( ) Build the IF Filter board (See Appendix F).
- ( ) Locate the 3.5" 8-pin IDC cable (RX-IFFILT – CA26). Connect one end to the IF Filter board. Leave the other end disconnected for now.
- ( ) Install the IF Filter board on the 6 tall standoffs in the receiver compartment with the filters facing down. Use six 6-32 x 5/8" hex male/female spacers to secure the board. Tighten the spacers securely, but do not overtighten to avoid damage to the PC board.
- ( ) Insert RF cable IF1 in the connector labeled J2 (9MHz in) on the IF Filter board.
- ( ) Insert RF cable IF2 in the connector labeled J3 (9MHz out) on the IF Filter board.
- ( ) Insert RF cable IF3 in the connector labeled J4 (455KHz in) on the IF Filter board.
- ( ) Insert RF cable IF4 in the connector labeled J5 (455KHz out) on the IF Filter board.
- ( ) Build the RXBPF board (See Appendix G).
- ( ) Locate the 2.5" 4-pin IDC cable (RX-BPFDC – CA25). Connect one side to J1 on the RXBPF board with the cable extending upward. Do not twist the leads.
- ( ) Lay the RXBPF board on top of the 5/8" hex male/female spacers. Secure it with six more 6-32 x 5/8" hex male/female spacers. Tighten the spacers securely, but do not overtighten to avoid damage to the PC board.
- ( ) Insert RF cable RF1 in the connector labeled J4 (To Rcvr) on the RXBPF board.
- ( ) Insert RF cable RXANT to the RF connector labeled J3 (Rx Antenna) on the RXBPF board. Dress the other end of this cable through the large round hole in the small bracket and into the PC compartment. It will be attached to the RX Antenna jack on the rear panel in a later step.
- ( ) Insert RF cable RXBPFMAIN-TX to the RF connector labeled J2 (Main Antenna) on the RXBPF board. Dress the other end of this cable through the large round hole in the small bracket and into the PC compartment, then into the hole in large bracket right. This cable will be connected to the transmitter or the 100W

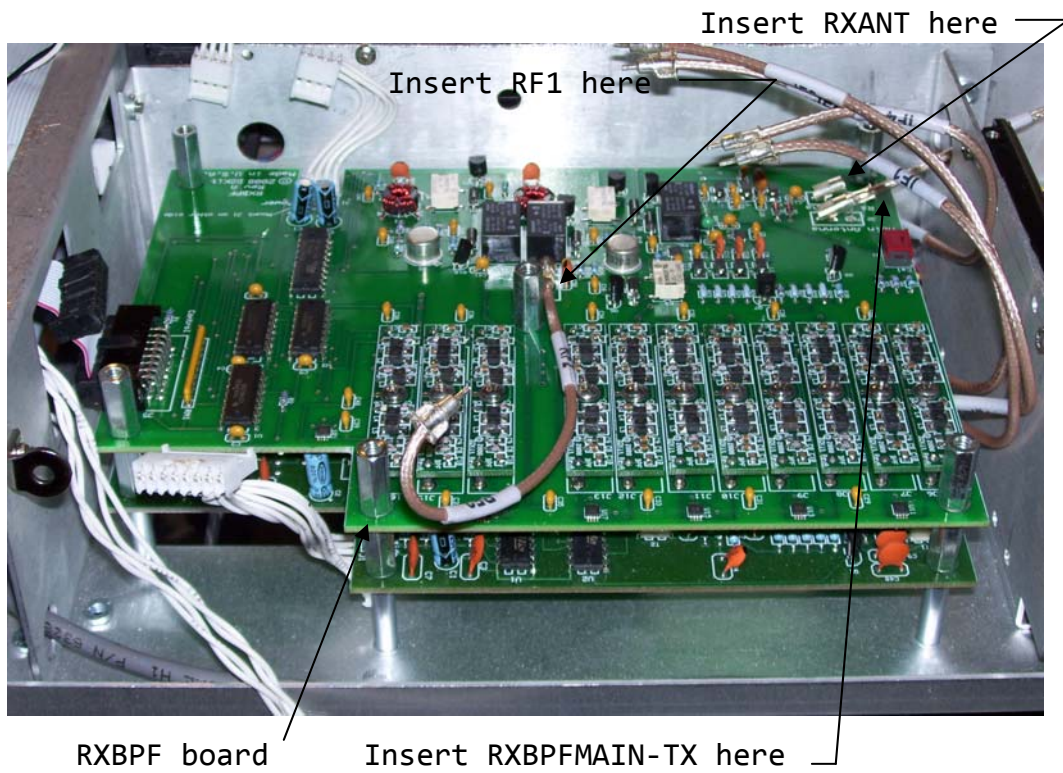
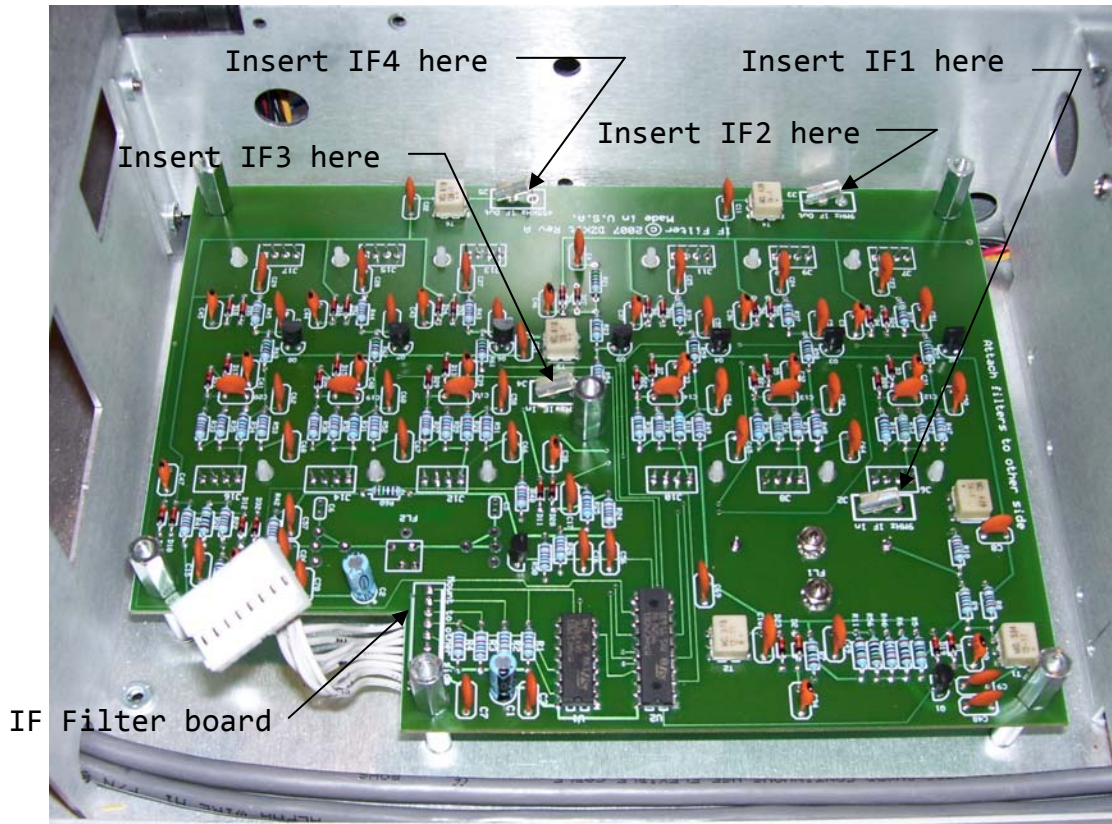

Pictorial 7.



amplifier once they are installed in later steps.

- ( ) Build the Receiver board (See Appendix H).
- ( ) Carefully place the receiver board on top of the six hex standoffs. Secure it with six 6-32 x 1/4" screws. Make sure no cables are stuck or pinched beneath the board.

Refer to Pictorial 8 for the following steps.

- ( ) Locate the 2.5" 4-pin IDC cable coming from the RXBPF board (RX-BPFDC – CA25). Connect it to J13 on the Receiver board.
- ( ) Connect the 2-pin connector coming from the S-meter to J19 (Meter) on the Receiver board.
- ( ) If you have installed the second meter, connect its 2-pin connector onto J25 (Tx Mtr) on the Receiver board.
- ( ) Locate the IDC cable that is connected to J11 (CONT-RXVOXST – CA14) on the Controller board. Connect the other end to J24 (Sidetone/VOX) on the Receiver board.
- ( ) Locate the 3" 8-pin IDC cable coming from the IF filter board (RX-IFFILT – CA26).

Connect it to J10 on the Receiver board.

- ( ) Locate the 10" 3-pin IDC cable labeled RX-TXLINE (CA29). Attach one end to J23 (Line/VOX) on the receiver board. Run the other end through the large round hole in the small bracket and then through the round hole in the right bracket and into the Transmitter compartment.
- ( ) Locate the 10" stereo minijack to 3-pin IDC cable (RX-RPLINEIN – CA30). Remove the knurled nut from the minijack and save it. Connect the IDC end to J21 (Ext In) on the Receiver board. Pass the other end through the large round hole in the small bracket and through the hole in the back panel labeled "Line In". Reattach the nut and tighten securely.
- ( ) Locate the 15" stereo minijack to 3-pin IDC cable (RX-RPLINEOUT – CA31). Remove the knurled nut from the minijack and save it. Connect the IDC end to J16 (Ext Out) on the receiver board. Pass the other end around the right side of the receiver stack, under the right side of the small bracket and through the hole in the back panel labeled "Line Out". Reattach the nut and tighten securely.

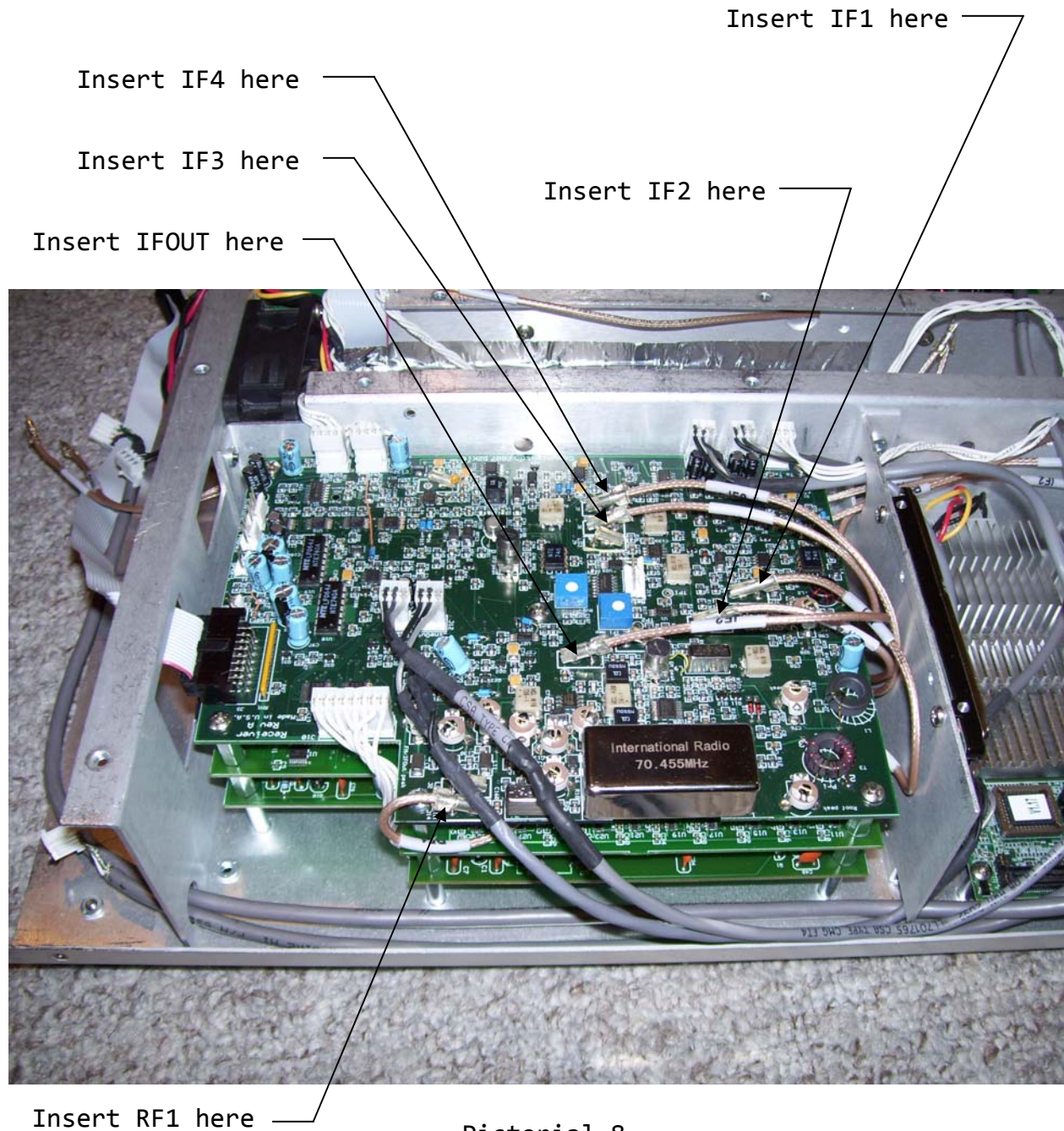

Pictorial 8



- ( ) Insert RF cable RF1 into J14 (RF In) on the Receiver board.
- ( ) Insert RF cable IF1 into J17 (IF1-To9M) on the Receiver board.
- ( ) Insert RF cable IF2 into J11 (IF2-From9M) on the Receiver board.
- ( ) Insert RF cable IF3 into J8 (IF2-To455) on the Receiver board.
- ( ) Insert RF cable IF4 into J7 (IF2-From455) on the Receiver board.
- ( ) Insert RF cable RXL01 into J2 (marked L01) on the Receiver board.
- ( ) Insert RF cable RXL02 into J15 (marked L02) on the Receiver board.
- ( ) Insert RF cable RXL03 into J8 (marked L03) on the receiver board.
- ( ) Insert RF cable RXL04 into J7 (marked L04) on the receiver board.
- ( ) Insert two chassis-mount phono connectors into the holes labeled "455KHz IF out" and "Rx Antenna" on the back panel, from the inside, and tighten the nuts on the outside. Be careful not to scratch the panel. Bend the solder lug inward slightly.
- ( ) Attach a gas discharge tube between the RX ANT jack center conductor and the solder lug.
- ( ) Solder the center conductor of the RXANT cable to the RX ANT phono connector on the back panel.
- ( ) Solder the RF cable center conductor of the IFOUT cable to the center pin of the 455KHz IF out phono jack.
- ( ) If you have installed the PC option, locate the cable assembly that has three cables attached to a 2mm rectangular connector (PC-RX/TX – CA32). Attach the rectangular connector to CN2 on the PC (located along the back edge). Pass the cable with the 2-pin IDC connector on the other end through the hole in the right bracket and into the transmitter compartment. Pass the shorter of the two cables with 3-pin IDC connectors through the large round hole in the small bracket and connect it to J20 (Line In) on the receiver board. Connect the longer of the cables to J12 (Line Out) on the receiver board. Dress it along the bottom of the chassis and under the small



bracket.

- ( ) Connect the cable that is wired to the headphones (RX-HP – CA24) to J6 (Phones) on the receiver board.
- ( ) Locate the ribbon cable that has two connectors on one end (CONTDATA-RX-BPF – CA20) that you connected to the controller earlier. Insert the connectors through the rectangular hole near the right side of the receiver stack. Push the bottom connector into the RXBPF board and the top one into the receiver board.
- ( ) Insert the RF cable TX-TUNER/AMP into J5 (From Tx) on the DCD/Tuner board. Loop this cable through the hole in the center wall of the left bracket and into the transmitter compartment.
- ( ) Locate a 10" 4-pin-5-pin IDC cable (DCDIST-RX – CA51). Connect the 5-pin end to J11 (Rx) on the DCD/Tuner board. Dress this cable along the top of the unit, around the fan and into the receiver compartment. It is important that this cable not protrude above the fan so that it does not get pinched when the top cover is installed, so position it in the gaps around the back and sides of the fan.
- ( ) Locate a 15" 2-pin IDC cable. Cut it so that one length is 9". Cut the other piece so that it is 4" long. Strip all exposed ends of both cables to a length of 1/4". Tin all 4 ends. Twist the wires about 2 turns per inch if they are not already twisted. Place a 1/2" length of heatshrink tubing over each wire. Using the 9" length of cable, solder the red wire to + and the black wire to - on the left speaker. Position the heatshrink over the terminals and heat them with a heatgun or soldering iron. Dress the cable along the top of the chassis, over the fan, and plug the connector into J22 (SPKR-L) on the Receiver board.
- ( ) Using the 4" length of 2-wire cable you just prepared, solder the red wire to + and the black wire to - on the right speaker. Position the heatshrink over the terminals and heat them with a heatgun or soldering iron. Plug the connector into J4 on the Receiver board.





## STEP-BY-STEP ASSEMBLY - Receiver Alignment/Tests

When so instructed, connect a voltmeter to the test points described below (red to the noted test point, black to any point on the chassis).

- ( ) Disconnect the 4-pin power cable from the DCD/Tuner board (J11) that goes to the Receiver board (DCDIST-RX – CA51).
- ( ) Measure the resistance between pin 1 and ground on the connector that is at the end of the cable. (Use the exposed metal pins on the side of the connector.) It should be >1K ohms. Now measure the resistance between pin 2 and ground. It should also read > 1K ohms. Finally, measure the resistance between pin 4 and ground. It should read > 150 ohms. If you measure a short at any of these points, refer to the troubleshooting section of the Service Manual.
- ( ) Reconnect the Receiver power cable and turn on the radio by applying DC power to the APP connectors on the back panel and pushing the on/off switch.
- ( ) Set both trimpots on the Receiver Board in their middle position.
- ( ) Disconnect any antennas from the antenna jacks on the Back Panel.
- ( ) Make sure that the center conductors of the two RF cables that are resting in the transmitter compartment are not touching the chassis.
- ( ) Turn on the radio.
- ( ) Enable the internal attenuator by pushing only the “Pre2/Atten” button. Do **not** push the “Preamp1” button.
- ( ) Set the RF Gain control to the maximum clockwise position.
- ( ) Press MENU, then NEXT/MODE until the menu page appears that has “RFG Cal” as one of the selections. Select it by rotating the large tuning knob. Touch the red voltmeter lead to TP1 and then turn the small knob to get a voltage reading of 3.75V.
- ( ) Touch the red voltmeter probe to TP2 and adjust RV5 on the receiver board to get a voltage reading of 4.0V.
- ( ) Rotate the RF Gain control to the counterclockwise position. Note that the S-meter rises to a maximum. Return the control to the clockwise position.



The above steps set the Receiver's Automatic Gain Control (AGC) threshold voltage, which also zeroes the S-meter. (It may actually read slightly above 0 but should not read higher than S1.)

- ( ) Flip switch S1 on the RXBPF board to the "Cal" position.
- ( ) Locate two RF connectors and solder them together, back to back.
- ( ) Connect the TXBFO cable that is resting in the transmitter compartment to one side of the connector assembly you just made, and connect the Main Antenna input on the BPF board to the other. Be careful not to let the center conductor touch the chassis.
- ( ) Press NEXT/MODE until CW(USB) mode is selected.
- ( ) Tune the frequency to 4915.00 kHz, with the mode set to CW.
- ( ) Press the MENU button, then press NEXT/MODE again until you see a selection called "Rx Cal". Select it with the large tuning knob and then turn it on by rotating the small knob to the "On" position. Press MENU again to exit menu mode.
- ( ) Using a small, insulated screwdriver, adjust the 7 trimmer capacitors (in a group to the right of the Inrad roofing filter) so that you see a maximum reading on the S-meter. Some trimmers may appear to do nothing at this point.
- ( ) Press the Pre2/Atten button, which disconnects the internal attenuator when Preamp1 is also on. Both preamp LEDs should now be on.
- ( ) Peak the S-meter reading by adjusting the main tuning knob.
- ( ) Using a small, insulated screwdriver, adjust the remaining three trimmer caps (left side of Inrad roofing filter) to achieve a maximum reading on the S-meter.
- ( ) Adjust variable inductor L5 for a maximum reading on the S-meter.
- ( ) Press MENU. Select the menu that includes the settings for AGC control. Adjust the menu selection for two *pre-amps* until the meter reads S9.
- ( ) Press the Pre2/Atten button on the front panel. Make sure Preamp1 is ON.
- ( ) Adjust the menu selection for



*one preamp* until the meter reads S9.

- ( ) Press the Preamp1 button. Both preamps LEDs should now be OFF.
- ( ) Adjust the menu selection for *no preamps* until the meter reads S9 or as close as you can get to S9.

The above steps calibrate the receiver's RF gain so that a signal at the antenna of 50uV (-73dBm) causes the S-meter to read S9 whether using zero, one or two preamps.

- ( ) In menu mode, rotate the large knob until the mode is selected, then rotate the small knob to select FM.
- ( ) Rotate the NB Thr/FM Sql knob on the front panel until you can hear audio coming out of the speakers.
- ( ) Press NEXT/MODE until you see a selection called "FM Cal". Select it with the large tuning knob and then turn it on by rotating the small knob to the "On" position. Press MENU again to exit menu mode.
- ( ) Using a small, insulated screwdriver, re-adjust the 7 trimmer capacitors (in a group to the right of the In-rad roofing filter) so that you see a maximum reading on

the S-meter.

- ( ) Using a small screwdriver, adjust variable inductor L9 ("FM Peak") for a maximum reading on the S-meter. If you have an oscilloscope, adjust L9 so that the audio signal on the ungrounded side of R2/C122 is symmetric.
- ( ) Adjust trimpot RV2 for a mid-scale reading. The "S" value is not meaningful in FM. This is just a relative signal strength indicator.
- ( ) Remove the TXBFO cable and ANT cables from the back-to-back RF connector, place some electrical tape over the ends and leave them in the transmitter compartment.
- ( ) Set the Rcv/Cal switch to Rcv on the RXBPF board.
- ( ) Turn off the FM Cal function by rotating the small knob so that the selection reads "Off".
- ( ) Press MENU again to exit menu mode.
- ( ) Wait 10 seconds for current menu settings to be saved, then turn off the radio and remove DC power.

This completes receiver alignment.



## STEP-BY-STEP ASSEMBLY-Transmitter Integration

- ( ) Build the Transmitter board and attach it to its heatsink (See Appendix I).  
Transmitter board.
- ( ) Build the TXBPF board (see Appendix J).
- ( ) Attach the TXBPF board to the back of the transmitter board using two 4-40 x 3/16" screws. Be sure to carefully align all four connectors. The notches at the tops of the two boards should align with each other.
- ( ) Place a piece of cardboard or other thick insulator on top of the chassis. Lay the Transmitter on top of the insulator, across the left and right large brackets, heatsink down. All the cables and wires that connect to it should now be present in the Transmitter compartment.
- ( ) Locate the fan cable. Connect it to J15 (Fan) on the Transmitter board.
- ( ) Locate an 8-pin to 5-pin and 3-pin cable (DCDIST-TX – CA4). Connect the 8-pin connector to J7 (Tx) on the DCD/Tuner board. Attach the 5-pin connector on the other end of the cable to J5 on the Transmitter board. Attach the 3-pin connector to J18 on the
- ( ) Locate the 4-pin IDC cable coming from the front panel compartment. Connect it to J14 on the Transmitter board.
- ( ) Insert RF cable TXBFO into J9 (TXBFO) on the Transmitter board.
- ( ) Insert RF cable TXVFO into J10 (TXVFO) on the Transmitter board.
- ( ) Push the connector on the gray ribbon cable (CONTDATA-TX – CA21) into J1 on the Transmitter board.
- ( ) Insert RF cable TX-TUNER/AMP (CA47) into J11 (RF Out).
- ( ) Insert RF cable RXBPFMAIN-TX into J8 (RxBPF).
- ( ) Connect the 2-pin IDC Microphone cable coming from the front panel to J4 (Mic) on the Transmitter board.
- ( ) Attach the threaded #4 x 1 1/4" hex female/female spacer to the transmitter using a 4-40 x 3/16" screw.
- ( ) Holding the cables out of the way, lower the transmitter into its compartment and align it with the board guide



on the bottom. Slide it up against the back panel, feeding the three phono connectors through their holes. Secure it with two 2-56 x 5/8" panhead machine screws mounted on the back panel, two #2 lockwashers and two 2-56 nuts. *TIP: The lockwashers and nuts are small and easy to drop. Use double stick tape on your finger to hold them as you position them.*

- ( ) Attach the 1 1/4" spacer to large bracket right using a 4-40 x 3/16" screw.
- ( ) Connect the 2-pin IDC Microphone cable coming from the PC to the connector labeled PCMic on the Transmitter board.
- ( ) Connect the 3-pin IDC cable coming from the receiver to J6 (VOX/Lin) on the Transmitter board.
- ( ) Dress RF cable RXBPFMAIN-TX through the notch on the back of the board, into the PC compartment and then into the Receiver compartment. Insert it into the Main Antenna input on the BPF board.
- ( ) With all cables installed, make sure they are dressed neatly without kinks.

This completes transmitter integration.

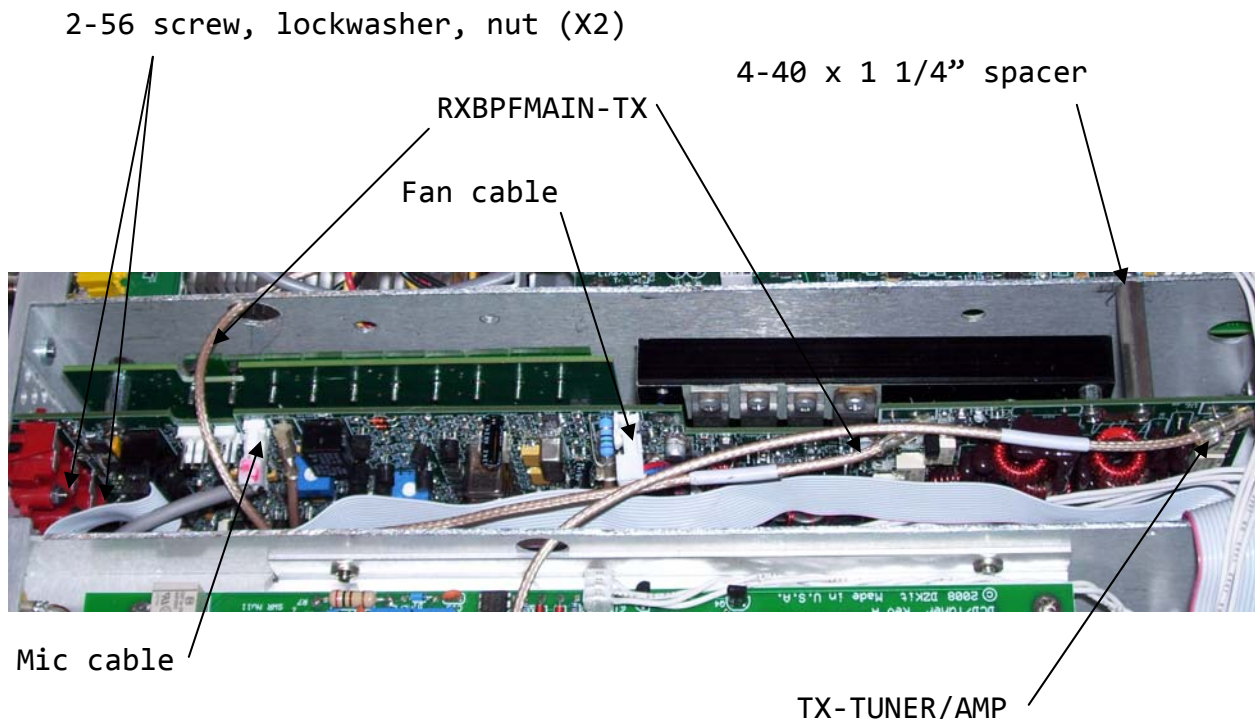

Detail 7. Transmitter integration



## STEP-BY-STEP ASSEMBLY

### Transmitter, SWR Alignment/Tests

- ( ) Apply power to the radio. If you observe anything out of the ordinary, turn off power at once. With the transmitter installed but not transmitting, you should see no change in anything – the receiver should work, the front panel should light up, and you should not see smoke!
- ( ) Select CW(USB) mode and set the frequency to 14.300MHz. Connect a dummy load to the antenna A jack via an RF power or SWR meter. Connect a key to the front or back panel MANUAL key jack. Select Forward Power on the TxMeter entry in the menu. Set the Mic Gain control on the front panel to the 12:00 position (mid-scale). Set the RF Power control counterclockwise (“P-0.0”). If you are performing this procedure after having already installed the 100W amplifier, select the “Amp” option in Menu2 for “Int 10W”, which tells the radio that the amp is not installed. This will cause it to be bypassed for the following tests.
- ( ) Press the key. As you do so, gradually increase the RF Power control to maximum. You should see the power output register on the power meter. Stop when it reaches 5.0W. Now look at the forward power indication on the built-in analog meter. Adjust RV1 on the DCD/Tuner board (FWD) until the meter reads as close to 5.0W as possible. (Note that the scale is 12W, not the marked 120W, when the amplifier is disabled. Therefore, 5W is a little less than mid-scale.)
- ( ) Select Refl Pwr on the meter from the TxMeter menu. Adjust RV2 (REFL) on the DCD/Tuner board until the meter reading dips. Adjust trimmer C17 on that board for as close a reading to 0 as possible.
- ( ) Repeat the previous two steps until the forward power reads 5.0W and the reflected power reads 0.
- ( ) Slowly increase the RF Power control and observe the meter reading. Make sure it agrees with the external power meter. If not, re-tweak the trim pots and C17.
- ( ) Release the key. Select USB mode.
- ( ) Turn on Full Duplex from the menu \*or\* listen to your signal on a nearby monitor receiver. Connect a microphone



to the front panel mic jack. Press the PTT button. Adjust RV1 on the Transmitter board so that the carrier is at a minimum.

- ( ) Select LSB. Re-adjust RV1 for minimum carrier. Repeat the previous step until USB and LSB have equally low carrier. Although you may be able to hear it when monitoring your own signal, the carrier suppression is sufficient that it will not be audible on the air.
- ( ) Press the "Proc" button on the front panel. Set the Proc Level control to mid-scale. From the menu, select "Comp" (compression) as the TxMeter function. Adjust Mic gain and RF Proc controls so that the RF Compression reads no higher than 12dB and the

signal sounds clean and readable with little distortion.

- ( ) Select AM mode on both the transmitter and the monitor receiver. Press the PTT button and speak into the microphone. Verify that your AM signal is readable as an AM signal.

- ( ) Select FM mode on the transmitter and monitor receiver. Press the PTT button and speak into the microphone. Verify that your FM signal is readable as an FM signal. The default bandwidth of the narrow-band signal is 2.4KHz. If you plan to use 4.8KHz, change it to this in the appropriate menu.

This completes alignment and test of the Transmitter board and SWR meter.



## STEP-BY-STEP ASSEMBLY-100W PA Integration

Refer to Pictorial 9 for the following steps.

- ( ) Build the amplifier board and attach it to its heatsink (See Appendix J).
- ( ) Remove power from the Sienna.
- ( ) Disconnect the fan connectors from the DCD/Tuner board and push the connectors down through the opening in the tray. Remove the two screws holding on the PS Cover and pull the assembly off.
- ( ) Set the assembled 100W PA beside (to the left of the Sienna as viewed from the front) with the heatsink facing down and connectors J3 closest to the front. Place the PS Cover 2" or so behind the 100W PA assembly.
- ( ) Connect the fan wires to J7 and J8 (marked "Fans") on the 100W PA assembly.
- ( ) Locate the 18# red wire that was supplied with the 100W PA kit. Cut a 12" length and strip 1/2" off one end and 1/8" off the other. Tin both ends by applying a small amount of solder. Crimp and solder a #6 wire lug to the 1/8" end.
- ( ) Attach the lug to the "V+" screw terminal on the DCD board by removing the screw completely, inserting the screw through the lug and back into the terminal. For now, position the cable so that it reaches the fuseholder by going over the side of the chassis and on top of the 100W PA board. Solder the other end to the end lug on the fuseholder.
- ( ) Cut another piece of 18# red wire to 4". Strip 1/8" of insulation off of one end and 1/2" off the other end of the other wire and tin both ends. Insert the 1/8" end into the bottom side of the 100W PA Board into the pad marked W1 ("From Fuse"). Solder the other end to the side pin on the fuseholder. Bend the side pin back as far as possible against the body of the fuseholder.
- ( ) Temporarily remove the ribbon cable going to the transmitter and controller. Reconnect one side to J3 on the 100W PA Board and the other to J2 on the DCD/tuner board.
- ( ) Disconnect transmitter power by removing 8-pin connector J7 ("Tx") on the DCD/Tuner board.

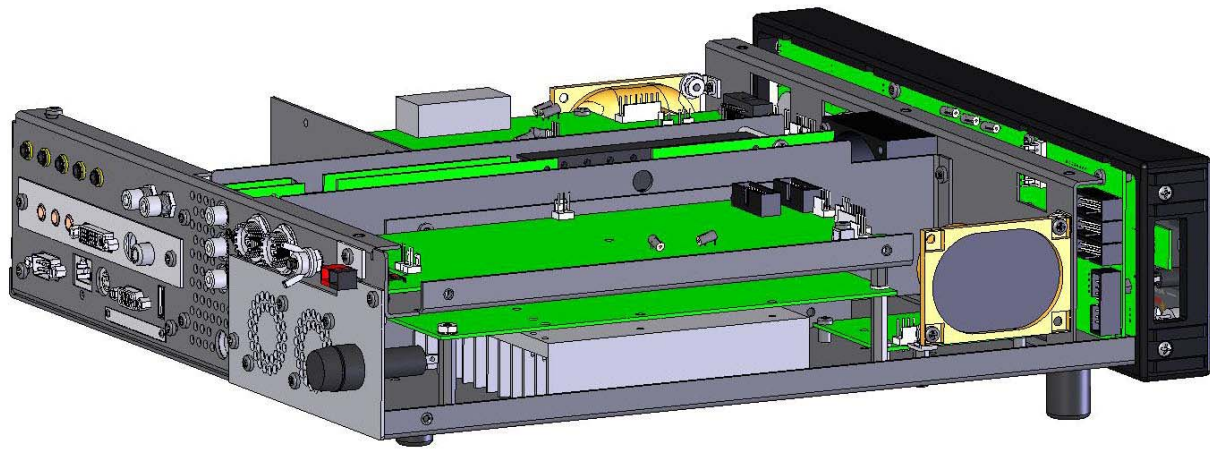

Pictorial 9. 100W PA Mounting



## 100W PA Alignment/Tests

**Note:** If your results are different from the expected ones, refer to the troubleshooting guide in the Service Manual.

- ( ) Connect a clip lead or other short piece of wire between a convenient ground and the Sienna chassis. If using a clip lead, the RF connector marked "Tx In" (J5) makes a handy place. You can also use one of the four corner mounting spacers.
- ( ) Using an ohmmeter, measure the resistance between V+ (W1 - "From Fuse") and ground. It should be > 1500 ohms.
- ( ) Turn trimpot RV1 ("PA Bias") all the way clockwise (right).
- ( ) Reconnect power to the Sienna DC input terminals and turn on the unit. If you smell smoke or observe power cycling on and off, switch the power off.
- ( ) Using a voltmeter, measure the voltage on the positive side of C2 (marked with a bar). It should read 5.0V +/- 0.15V.
- ( ) Verify that the fans are running at low speed. If you have a heat gun (a hairdryer will work), blow some heat on thermistor TH1, aiming at the bottom of the board. When the temperature rises enough, the fans should switch to high speed. You can hear the difference as they run faster. As the temperature cools back down, they should switch back to normal, low speed.
- ( ) Press the BAND button on the front panel and then use the large knob to cycle through the bands. As you do so, you should hear the low-pass filter relays K4-K13 switch on and off.
- ( ) Turn off BAND mode and press the MENU button. Select the menu item marked "Amp:" and then change the selection from "Int 10W" to "Int 100W". As you do so, you should hear relays K1, K2 and K3 switch. Alternate between "Int 10W" and "Int 100W" and you should hear the relays click on and off. Leave the selection at "Int 100W".
- ( ) Connect a microphone to the front panel mic jack and press the PTT button. If a microphone is not available, short the side of R2 that is connected to Q4 to ground. Measure the voltage at the junction of D5, D13 and R8. It should read 100V +/- 5V.
- ( ) RF calibration. STEPS NOT YET DONE!





## 100W PA Final Integration

- ( ) Turn off the radio and remove the power.
- ( ) Reconnect the long ribbon cable between the transmitter and controller boards.
- ( ) Disconnect the red power cable from the DCD/tuner board at the "V+" "To P.A." terminal.
- ( ) Remove the 6-32 x 2" hex M/F spacer that is attached between the tray and the bottom chassis in the 100W PA compartment. You will need to remove the 6-32 x 1/4" screw on the bottom of the chassis as well as the 6-32 x 3/4" screw and .05" Nylon washer. Save the washer and screws.
- ( ) Remove the 6-32 x 7/16" double-female spacer from the top of the 100W PA Board. Place the .05" Nylon washer over the male threads of the 1.5" spacer and reattach the 7/16" spacer to it.
- ( ) Re-insert the 6-32 x 3/4" screw in the corner of the DCD/Tuner board.
- ( ) Insert the 100W PA assembly about 1/3 of the way into the chassis from the back panel.
- ( ) Remove the RXBPFMAIN-TX/AMP RF cable (CA33) from J8 ("RxBPF") on the Transmitter board and the "Main Antenna" input on the RxBPF Board. Connect one end to J6 ("To RxBPF") on the 100W amp board. Dress the cable behind the 100W PA Board as shown in Detail 6.
- ( ) Remove the TX-TUNER/AMP RF cable (CA47) that is connected between J11 on the transmitter board and J5 on the DCD/Tuner board. Push one end of the cable into J5 ("Tx In") on the 100W PA Board. Bend it down along the side of the board and out the back as shown in Detail 6.
- ( ) Slide the 100W PA board all the way into the chassis so that the standoffs line up with the holes in the bottom chassis. Secure it with four 6-32 x 1/4" screws from the bottom of the chassis. As you slide it in, carefully maneuver the RF cables so that they do not jam against parts on the top or side of the board.
- ( ) Insert the TX-TUNER/AMP cable (CA47) and RXBPFMAIN-TX/AMP cable (CA33) into the hole in the left bracket that is located below the board and behind the heatsink. Pull both cables up from the transmitter compartment using needle-noise pliers. Connect TX-TUNER/AMP to J11 ("RF Out") on the transmitter.

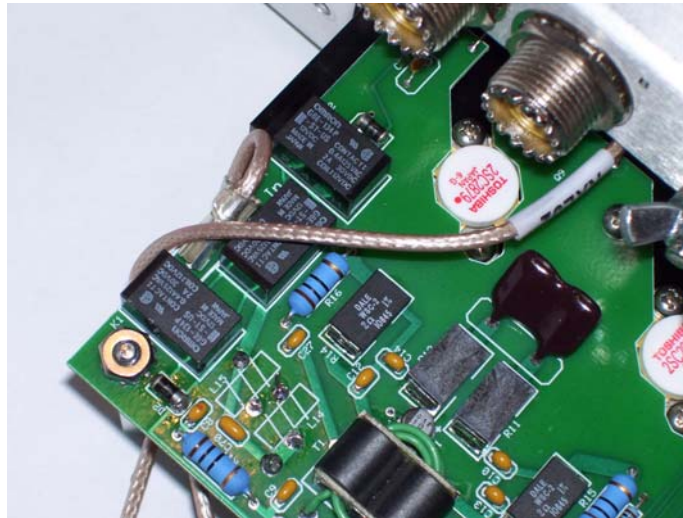

Detail 6. 100W PA RF cable routing

- ( ) Dress the RxBPFMAIN-TX/AMP cable through the notches in the transmitter and TxBPF boards and through the hole in the right bracket, then through the hole in the small bracket and into the Main Antenna jack on the RXBPF board. If you have trouble getting the cable to seat in the connector, unscrew the small bracket, seat the connector and then re-fasten the small bracket.
- ( ) Re-attach the PS cover to the back panel with two 6-32 x 1/4" screws.
- ( ) Run the red power cable from the fuseholder along the top of the heatsink and loop it around the end of the DCD/Tuner board. Re-attach it to the terminal on that board.
- ( ) Insert a short gray ribbon cable between J6 (To PA) on the DCD/Tuner board and J3 on the 100W PA board. This cable goes underneath the other one that is connected to J2.
- ( ) Locate a 15" cable with a 2-pin IDC's on each end (CA15). Connect one end to J19 (Amp) on the controller board. Pass this cable through the large rectangular hole in the bottom left side of the front bracket and connect it to J1 ("PA Curr") on the 100W PA Board.
- ( ) Connect RF cable AMP-TUNER (CA49) between J2 ("Antenna") on the 100W PA board and J4 ("From PA") on the DCD/Tuner board.

This completes installation of the 100W PA Option.



## STEP-BY-STEP ASSEMBLY-Final Assembly

- ( ) Turn on the radio and tune in a station that is transmitting on a known frequency, such as WWV at 10MHz. Adjust the TCXO adjustment pot at the top of the controller board until the received signal is exactly on frequency. If you have a spectrum analyzer, this can be done precisely by connecting the analyzer to RXLO1 and adjusting the pot until the frequency reads exactly 70.45700000 MHz in CW(USB) mode. Turn off power when done.
  - ( ) If you plan to use an electret style microphone that requires power, set the 5V/8V jumper on the controller board for the appropriate voltage. This supply is not capable of providing any appreciable current, so do not try to use it as a voltage source.
  - ( ) Apply a small amount of RTV adhesive (in the 3 oz. tube) to all toroids on the receiver and transmitter boards (and tuner and 100W amplifier boards if present). Just a small dab in one spot is sufficient. Do not coat the entire toroid with the adhesive.
  - ( ) Secure the front panel to the bottom chassis using four 6-32 x 1/4" screws (one or two should already be in place on the bottom).
  - ( ) Place the top cover on the radio and secure it to the chassis using six 6-32 x 1/4" flathead black anodized screws.
  - ( ) Secure the front panel to the top cover using four 6-32 x 1/4" panhead screws.
  - ( ) Slide the black plastic shroud over the front panel. Secure it with four 6-32 x 1/4" black anodized panhead screws, two on each side.
  - ( ) Affix the serial number sticker to the back panel between the LINE OUT and IF OUT connectors.
- This completes assembly and test of the Sienna transceiver.

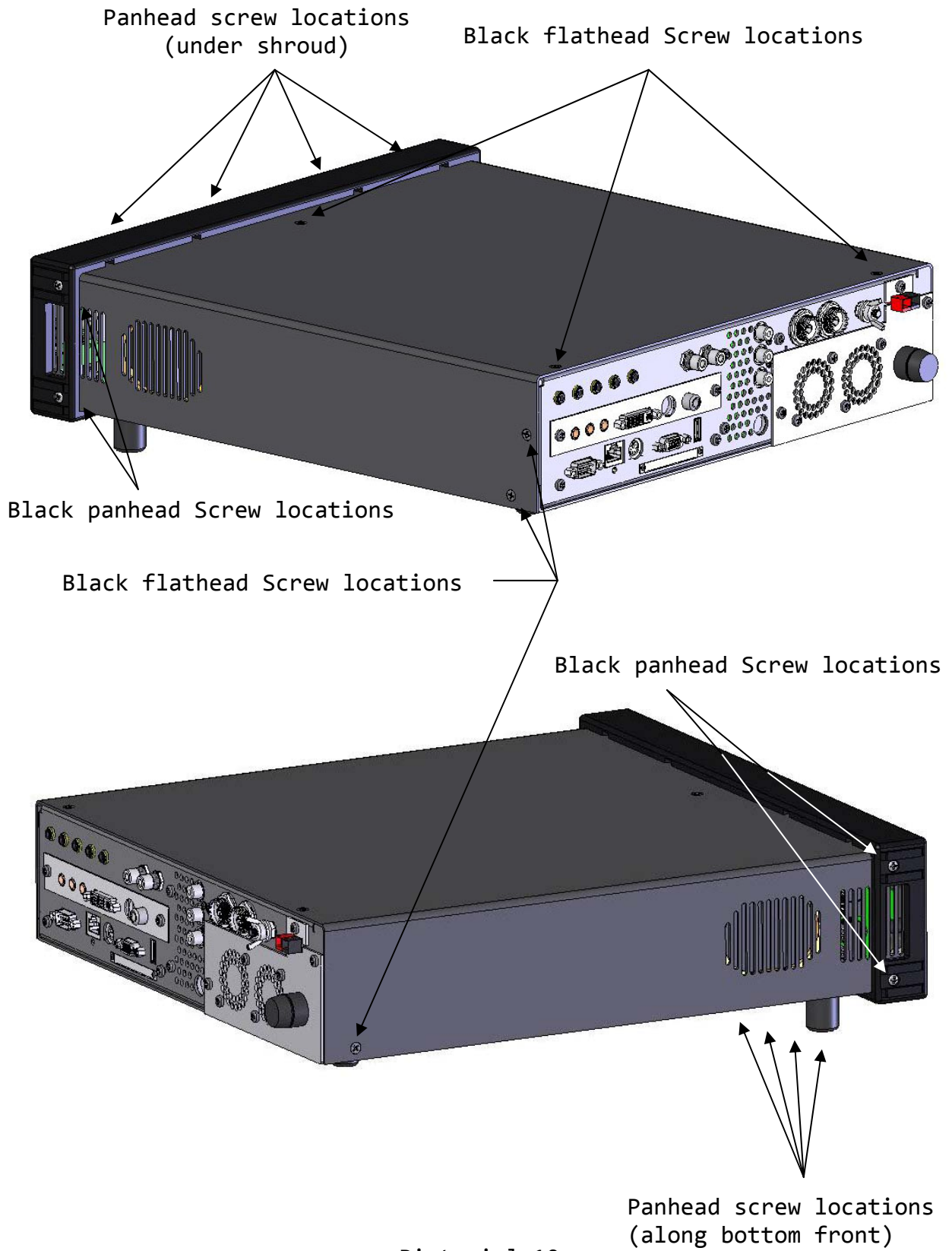

Pictorial 10



# Appendix A: PCPS Board (Option 105)

## PARTS LIST

Item	Part	Description	Qty
1	C1, C4	.47uF monolithic capacitor	2
2	C2, C3, C5	22uF/25V tantalum, low ESR (SMT)	3
3	F1	7A PTC Resettable fuse	1
4	J1	4-pin AMP connector (small)	1
5	J2	4-pin AMP connector (large)	1
6	JP1, JP2	2-pin jumper (male, PCB-mt)	2
7		2-pin jumper (female)	2
8	Q1	TIP41C TO-220 transistor	1
8	U2	AP1084 TO-220 regulator	1
9	R1	120 ohm 1/4W metal film resistor	1
9	R2	360 ohm 1/4W metal film resistor	1
10	U1	LM2940CS-9 regulator (SMT)	1
10	U3	LM2940CS-12 regulator (SMT)	1
11		4-40 x 1/4" screw	4
12		4-40 KEPS nut	2
13		#4 shoulder washer	2
14		TO-220 sticky-back insulator	2
15		Embedded PC w O/S installed on CF	1
16		CF bracket	1
17		Screw - #1x1/4" PH Phillips self-tapping	2
18		Jackscrew - 4-40 x 3/16" x 5/16"	4
19		Blank Board	1
20	CA3	DCDIST-PCPS Cable	1
21	CA32	PC-RX/TX	1

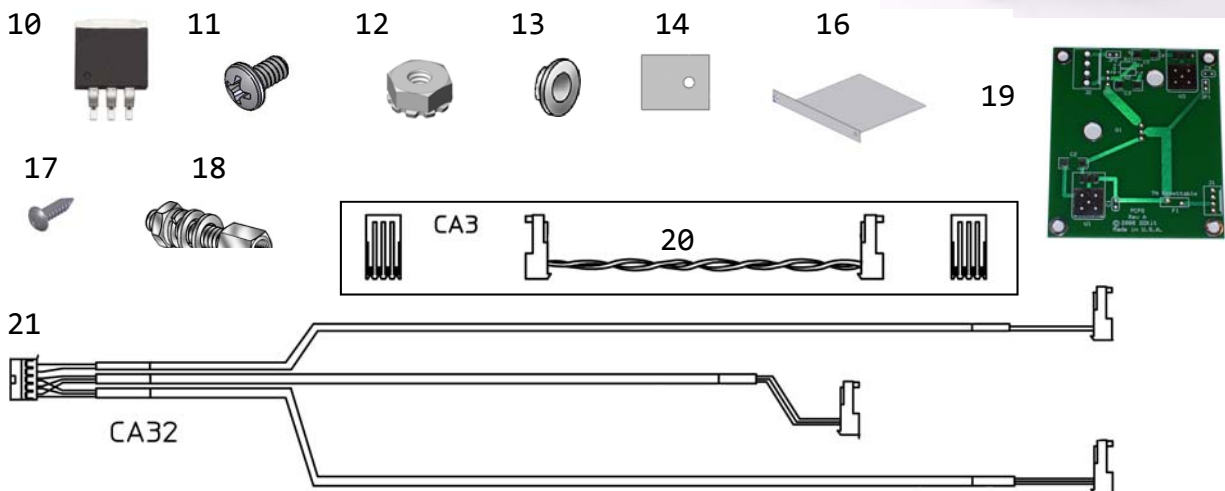
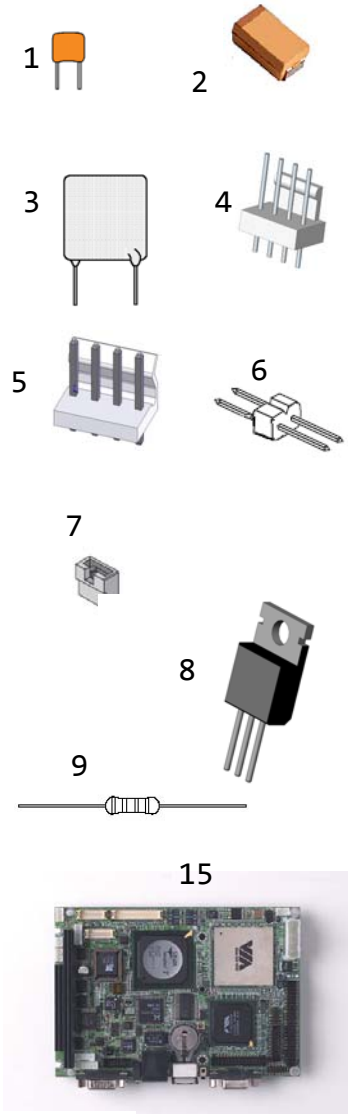



## STEP-BY-STEP ASSEMBLY-PCPS Board

*Highlight or check off each part on the bag label as you install it on the board. Unless otherwise instructed, load all parts of the same type from each bag and clip the leads after soldering.*

- ( ) Load and solder C1 and C4, 0.47uF monolithic capacitors. Clip the leads.
- ( ) Load and solder C2, C3, and C5, 22uF/25V SMT electrolytic capacitors. Be sure to observe correct polarity.
- ( ) Load and solder 2-pin jumpers JP1 and JP2. Insert the female shorting blocks on both connectors.
- ( ) Load and solder J1, a 4-pin AMP MTA connector. Note that the silkscreen for the connector has a heavy bar on one end. This is the side of the connector that has a solid tab rising out of the connector body.
- ( ) Load and solder J2, a large 4-pin AMP MTA connector. Again, be sure to put the tab on the side with the heavy outline.
- ( ) Load and solder U3, a 12V regulator. This is a surface-mount device. Place it on the pads and hold it while soldering one pin securely, then go back and heat the other pads. Apply solder along the edge of the metal tab. Turn the board over and apply solder to the 5 holes beneath the part.
- ( ) Look at U2 carefully. If it is an AP1084 with no suffix, load resistor R2. If it has a -50 suffix, clip one lead on R2 and insert the lead into the pads marked R2. Clip the leads.
- ( ) If the AP1084 is marked with a -50 suffix, discard R1. If not, load, solder and clip the leads of R1.
- ( ) Load and solder F1, the 7A Resettable fuse. When inserting the fuse, leave 1/8" of the leads visible above the board. After soldering the part, bend it 90 degrees to lie flush with the board. Clip the leads.
- ( ) Load and solder U1, a 9V SMT regulator. Use the same procedure you used for U3.
- ( ) Position U2 on top of the board so that the hole in the tab lines up precisely with the center of the access hole on the board. With the mounting hole centered, note the location of the 3 pins and



bend them up at that point. Insert U2 into the board from the bottom. Tack (solder lightly) one pin to keep the part in place until the board is mounted to the chassis. *Do not clip its leads.*

( ) Repeat the previous step for Q1. Since Q1 and U2 look alike, check both parts carefully to make sure the right one is loaded at the right place. *Do not clip its leads.*

( ) Check your work.

This completes assembly of the PCPS board. Set the other parts (PC, screws, cables, etc.) aside.

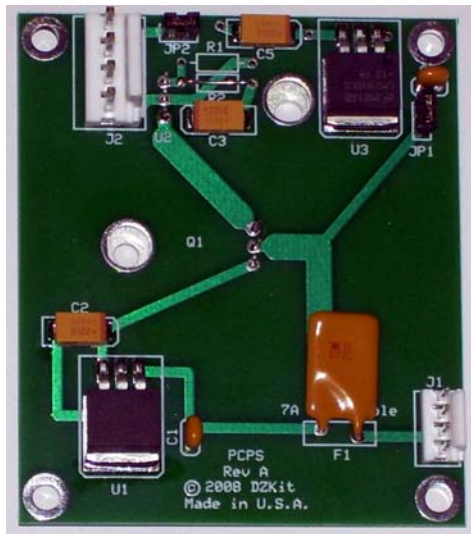

PCPS Board loaded, front

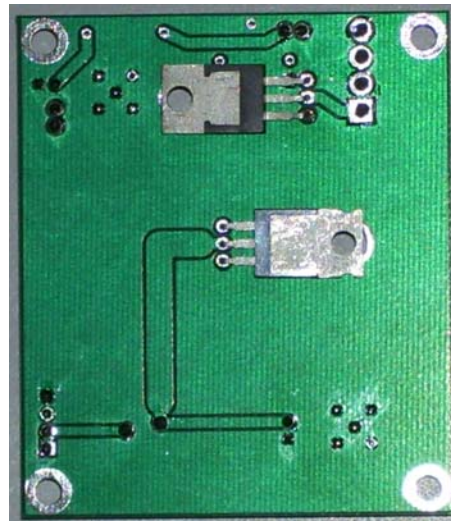

PCPS Board loaded, back



## Appendix B: RS232 Board

### PARTS LIST

Item	Part	Description	Qty
1	J1	14-pin 2mm connector	1
2	J2	DB-9 PC-mt right-angle connector	1
3	R1,R2,R3,R4,R5	100 ohm 1/8W resistor	5
4	C1,C2,C3,C4,C5	.01uF monolithic capacitor	5
5		RS232 Board blank	1

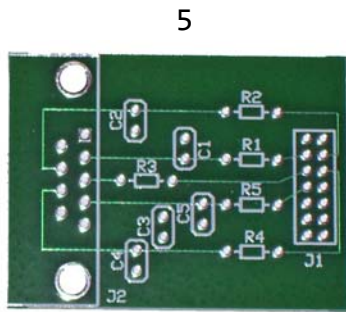

RS232 Board, blank

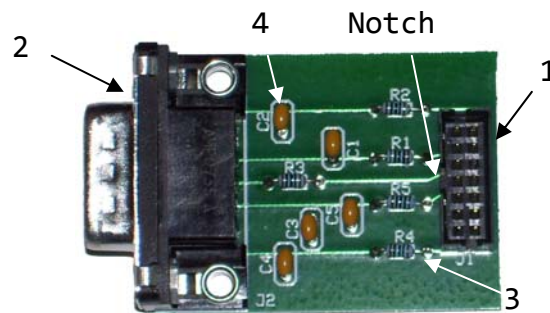

RS232 Board, assembled



## **STEP-BY-STEP ASSEMBLY-RS232 Board**

- ( ) Load and solder all resistors. Clip the leads.
- ( ) Load and solder all capacitors. Clip the leads.
- ( ) Load and solder the 9-pin D-subminiature connector.
- ( ) Load and solder the 14-pin rectangular connector. The side with a notch faces inward (See note on photo.)

This completes assembly of the RS-232 Board. This board is only used when no PC is installed in the Sienna.



## Appendix C: DCD/Tuner Board [DCD Section]

### PARTS LIST

Item	Part	Description	Qty
1	C15	100pF silver mica capacitor	1
2	C13, C14	1000pF ceramic disk capacitor	2
3	C3, C4, C5, C16, C18, C19, C21, C25, C26, C28	.1uF monolithic capacitor	10
4	C1, C2, C20, C22, C23, C29	100uF/25V aluminum electrolytic capacitor	6
5	C17	30pF trimmer capacitor	1
6	C24, C27	22uF/25V tantalum SMT	
7	D3, D4, D8	1N4733A 5.1V 1W Zener diode	3
7	D5, D9	1N5223B-2.7V Zener diode	2
7	D1, D2, D7	1N5711 Schottky diode	3
7	D11, D12	1N4007B diode	2
7	D10	1N5818 Schottky diode	1
8	D6	1N5404 power rectifier	1
9	F1	Fuse - 7A PTC Resettable fuse	1
10	J1, J2	16-pin 2-row .1" centers shrouded male header	2
11	J5, J6	2-pin AMP MTA male keyed header	2
12	J3, J9	3-pin AMP MTA male keyed header	2
13	J8	4-pin AMP MTA male keyed header	1
14	J4, J10	5-pin AMP MTA male keyed header	2
15	J7	8-pin AMP MTA male keyed header	1
16	J11, J14	Taiko-Denki RF jack	2
17	K15, K16, K17, K18	SPST 12V relay, 8A	1

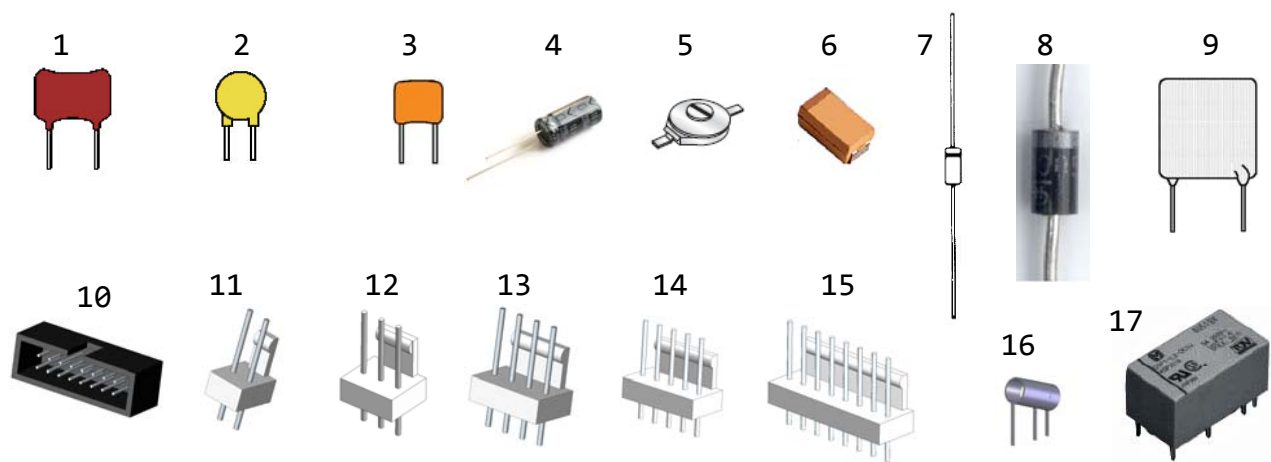



Item	Part	Description	Qty
18	L8, L9	47uH axial inductor	2
19	R7	200 ohm 1W	1
19	R29, R30	51 ohm 1W	2
19	R16, R26	470 ohm 2W	2
20	RFC1, RFC2	Type 77 Toroid	2
21	T1	FT50-43 toroid	1
22	RN1	Resistor network, .1" centers, 10-pin 10K	1
23	RV1, RV2	100K top adjust trimpot	2
24	W3	Vertical screw term PC-mt, 6-32 screw	1
		22# magnet wire	18"
		24# magnet wire (red)	36"
25		Nut - 4-40 KEPS nut	3
26		Screw - 4-40 x 1/4" PH Phillips M/S	3
27		#4 shoulder washer	2
28		TO-220 sticky-back insulator	2
29		Anderson Powerpole contact, right angle PCB mount	2
30		Anderson Powerpole housing - red	1
30		Anderson Powerpole housing - black	1
31	Q1	TIP41C Power NPN transistor, TO-220	1
31	Q3	STP80PF55 Power MOSFET, P-ch, TO-220	1
31	U8	AP1084-5 5V regulator, TO-220	1

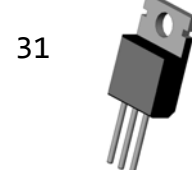
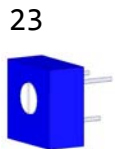
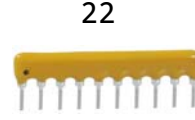
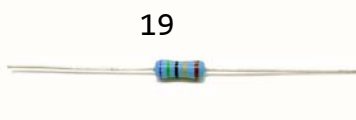
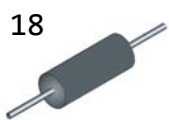



Item	Part	Description	Qty
32	Q2	2N3906	1
32	Q4, Q5, Q6, Q7	2N7000 MOSFET	4
33	U1, U2	74HC273 octal D flip-flop	2
34	U3, U4	ULN2803 relay driver	2
35	U6	LM339 quad comparator	1
36	U7	LM393 dual comparator	1
36	U5	LM358 dual op-amp	1
36	U10	MAX765 -9V regulator	1
37	U9	LM2940CS-9 SMT 9V regulator	1
38	R20	100 ohm	1
38	R8, R18, R21, R22	1K ohm	4
38	R4, R10, R17	3.3K ohm	3
38	R15, R25, R32, R33	4.7K ohm	4
38	R1, R2, R5, R6, R9, R14, R31	10K ohm	7
38	R3, R11, R13, R24	22K ohm	4
38	R28	165K ohm	1
38	R12, R19, R23, R27	1M ohm	3
39		Blank Board	1

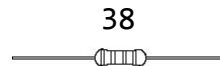



39

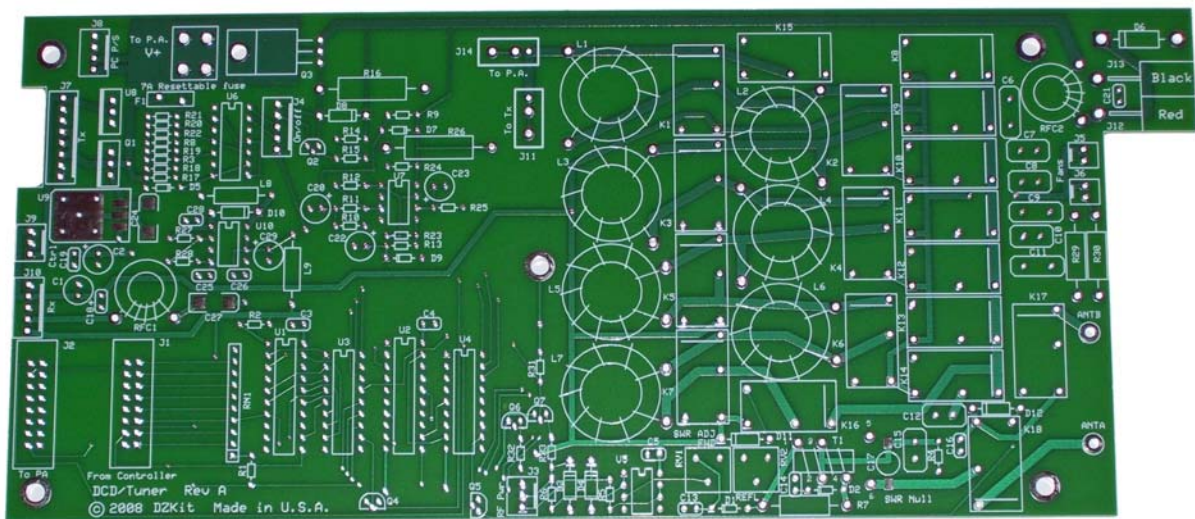



## STEP-BY-STEP ASSEMBLY-DCD Board

*Highlight or check off each part on the bag label as you install it on the board. Unless otherwise instructed, load all parts of the same type from each bag and clip the leads after soldering.*

- ( ) Load and solder all capacitors, one bag at a time, including C17, the 30pF trimmer capacitor, and electrolytic capacitors, being careful to observe polarity.
- ( ) Load and solder all resistors, one bag at a time. Clip the leads. Note that some resistors are in bags that also contain other parts.
- ( ) Load and solder all diodes, one bag at a time. Note that some diodes are in bags that also contain other parts.
- ( ) Load and solder inductors L8 and L9.
- ( ) Load and solder F1, the 7A Resettable fuse. Bend this part over slightly so that it does not hit the top cover when it is installed.
- ( ) Load and solder the resistor network. Be sure that the side with the dot goes into the square pad.
- ( ) Load and solder the trimpots, RV1 and RV2.
- ( ) Load and solder Q2. Orient this transistor with the flat side as shown on the silk-screen. The easiest way to insert this part is to insert one pin partway into the hole and then wiggle the other two pins into place, then push the part down gently. The transistor should be positioned so that the body is no higher than .1" off the board.
- ( ) Place Q3 over its pads so that the mounting hole lines up with the hole on the board. Note where the leads need to be bent to fit in the holes. Bend the leads of Q3 down and insert it into the board. Attach it with a 4-40 x 1/4" screw and 4-40 KEPS nut. The nut attaches to the bottom of the board. Solder and clip the leads.
- ( ) Load and solder Q4, Q5, Q6 and Q7 just as you loaded Q2.
- ( ) Install W3, the metal screw terminal, in the pads marked "To P.A. V+". *This part will get very hot while being soldered. Be careful not to burn your fingers.* Make sure the part is seated flush with the board.



- ( ) Insert the right angle Anderson Powerpole (APP) contacts into the red and black bodies as shown in detail B1.



Detail B1. APP assembly

- ( ) Attach the APP connectors together with the red and black bodies in the orientation labeled on the board. Position the connectors so that their bodies match the outline on the board, then bend the leads down. Load and solder the connectors to the board.
- ( ) Wrap five turns of #22 magnet wire around Toroid RFC1. Insert the toroid into the board with the cylinder facing vertically. Solder the leads. Maintain heat for about 1 minute, long enough to melt the coating and cause solder to flow onto the lead and the pad. Be sure your soldering iron is set to at least 750 degrees. Clip any excess leads. Using an ohmmeter, verify that there is continuity from one pad to the other. If not, reheat the connections.
- ( ) Repeat the previous step with RFC2, using 21 turns of #22 magnet wire. Mount RFC2 side-

ways instead of vertically. Make sure the wire is pulled tight to avoid having the part extend too high off the board. It must not touch the top cover once it is in place.

- ( ) Cut two lengths of #24 magnet wire 10" in length. Fold 1/4" of both ends of one wire back onto itself. Twist the two wires together, about 2 turns per inch. Wrap twelve turns of the finished wires around toroid T1. Insert the toroid into the board with the unfolded leads going into pins 1 and 2 and the folded leads into pins 3 and 4 (after unfolding them so they fit in the holes). Follow soldering instructions given in the previous step. See detail B2.

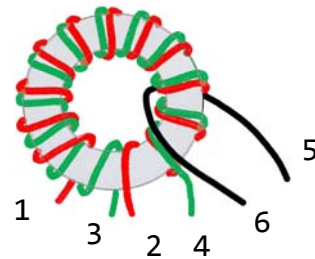

Detail B2. T1 construction (2nd winding shown in green for clarity)

- ( ) Cut 1 1/2" of 22# magnet wire. Insert the wire through toroid T1 and solder the ends to pins 5 and 6.
- ( ) If you did not purchase the antenna tuner, cut a 4" length of magnet wire. Insert



one end into the bottom pad of L7 with about 1/2" extending out the bottom of the board. Insert the other end into the top pad of L1 and pull the wire taut. Solder both ends using magnet wire soldering procedures described earlier. (If you would prefer to use a spare piece of ordinary insulated wire, you may do that instead.) If you do plan to install the tuner parts during initial assembly of this board, skip this step.

- ( ) Load and solder relays K15, K16, K17 and K18. They will only go in one way.
- ( ) Place U9, an SMT regulator, on the board where marked. Hold it in place while soldering one pin, then solder the other two pins. Finally, heat the tab and apply solder until it flows evenly along the bottom and sides of the tab. Apply solder to the five pads beneath the part on the bottom of the board too.
- ( ) Load and solder all remaining Integrated Circuits *except* U8, one bag at a time. Make absolutely sure that the ICs are inserted with pin 1 oriented correctly. When holding an IC horizontally so that you can read the printing from left to right, pin 1 is in the lower left corner. It is often marked with a dot, and there is also often a notch on that side of the IC. Pin 1 goes in the square pad on the board. Be especially careful when loading U5 and U7, since they look alike.
- ( ) Load and solder connectors J1 and J2. Pin one of these connectors is marked with an embossed triangle on one side. Line this up with the square pad. The side with a single notch faces the resistor network. Be sure the connectors are flush with the board.
- ( ) Load and solder all other connectors. Be sure to align the tab on the white AMP MTA connectors with the thick silkscreened bar. Be sure the connectors are flush with the board.
- ( ) Clip the pins of 8-pin connector J7 as close as possible to the board.
- ( ) Bend the leads of U8 \*up\* 0.8" from the end of the tab. Insert U8 from the bottom of the board, such that the bottom of the tab is 1/4" from the bottom of the PC board. Solder only one pin, just enough to keep the part from falling out. It will be secured to the chassis when the board is installed.



- ( ) Repeat the previous step with Q1. Since Q1 and U8 look alike, be sure the right part is placed in the right location.
- ( ) Check your work. Pay particular attention to connectors

and ICs, making sure that every pin is soldered. Hold the board at an angle and make sure all leads have been clipped.

This completes construction of the DCD (DC Distribution) portion of the DCD/Tuner board.

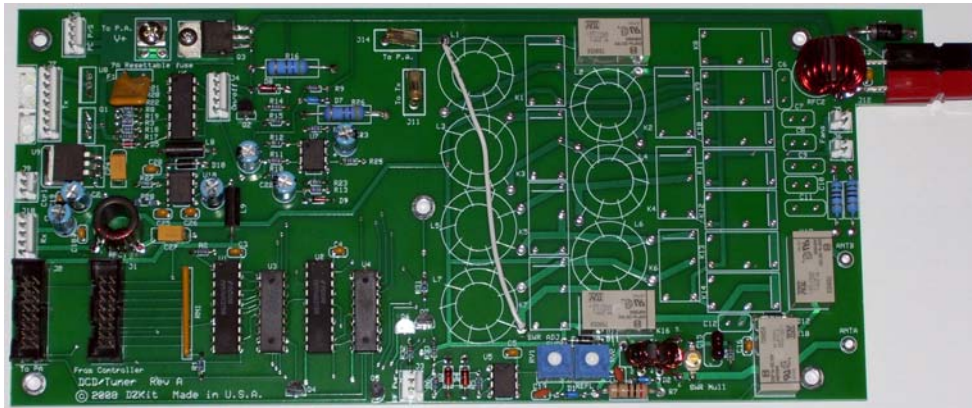

DCD Board, front, tuner section not installed

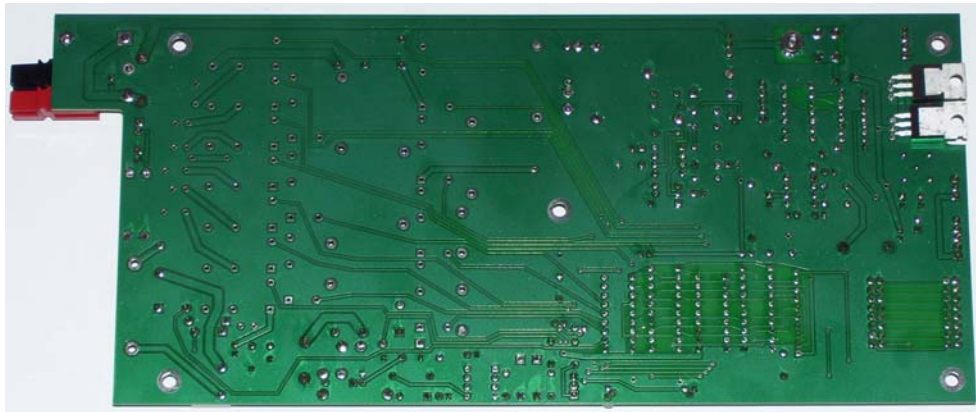

DCD Board, back, tuner section not installed



## Appendix D: DCD/Tuner Board [Tuner Section] (Option 102)

### PARTS LIST

Item	Part	Description	Qty
1	K1-K14	SPST 12V relay, 8A	14
2	C12	10pF silver mica (sm)	1
2	C11	20pF sm	1
2	C10	39pF sm	1
2	C9	82pF sm	1
2	C8	150pF sm	1
2	C7	330pF sm	1
2	C6	560pF sm	1
3	L1-L7	T80-2 Toroid	7
4		20# magnet wire	10'

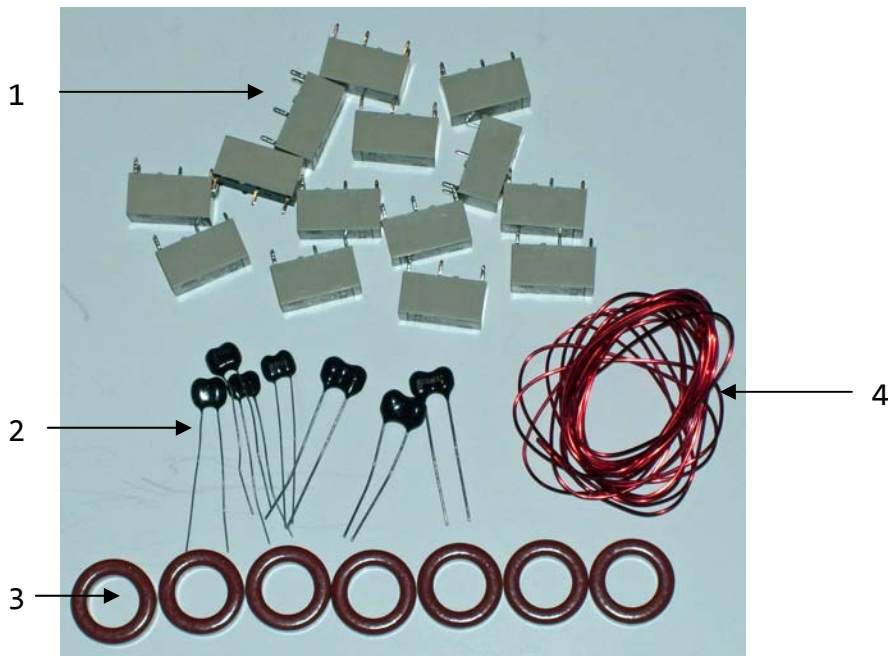

*Note: Capacitors are marked with actual value, e.g. "330", in pF.*



## STEP-BY-STEP ASSEMBLY-Tuner Board

*Note: Be very careful not to let your soldering iron touch the relays and trimpots on the DCD board as you install these parts.*

- ( ) If you are installing this option after you finished wiring your Sienna, first disconnect power, remove all cables and screws, and pull the DCD/Tuner board out of the unit.
- ( ) Wind 31 turns of 20 gauge magnet wire around toroid L1. See detail. Each time the wire enters the toroid counts as one turn. Leave about 1/2" lead exposed. Do not space the leads evenly around the core – wind them tightly together. See photo of assembled unit.
- ( ) Wind 22 turns of magnet wire around toroid L2. See photo.
- ( ) Wind 15 turns of magnet wire around toroid L3. See photo.
- ( ) Wind 10 turns of magnet wire around toroid L4. See photo.
- ( ) Wind 5 turns of magnet wire around toroid L5. See photo.
- ( ) Wind 3 turns of magnet wire around toroid L6. See photo.
- ( ) Wind 2 turns of magnet wire around toroid L7. See photo.
- ( ) Load and solder all toroids. Be sure the toroids lie flat on the board and tighten the leads as much as possible. Once the board has been tested, you will apply a small amount of glue to keep the toroids from moving, but it is not necessary to do so at this time. Apply heat to each lead for at least one minute to be sure that the coating melts off and the lead is securely soldered to the board. Then clip excess leads.
- ( ) Load and solder all silver mica capacitors. Clip the leads.
- ( ) Load and solder all 14 relays.
- ( ) Check your work.
- ( ) If this is an upgrade, reinstall the board and reconnect cables.
- ( ) Locate the tube of RTV (Chassis Parts bag). Once assembly and test of the tuner is completed, use a small amount of RTV on the toroids to keep them from moving. ***Do not use the RTV on the components at this time.***

This completes assembly of the Tuner section of the DCD/Tuner board.

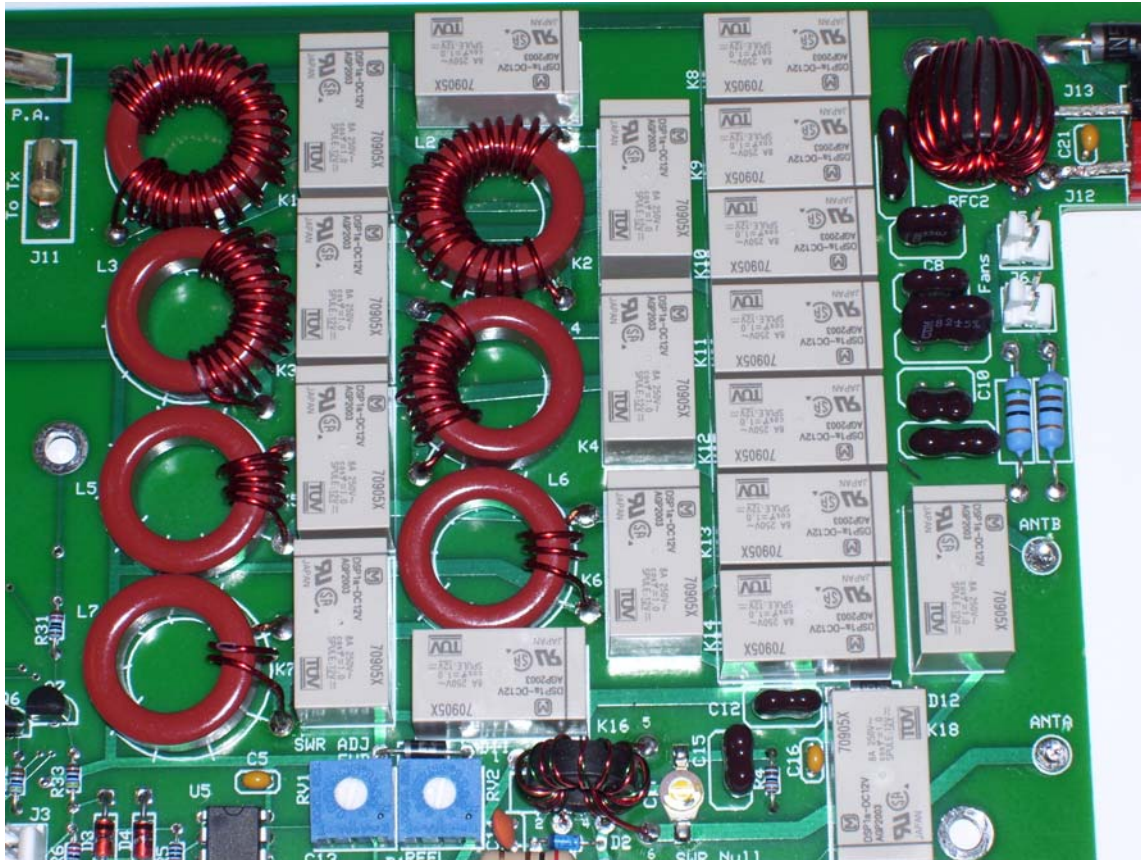

Detail photo showing correct winding of tuner toroids

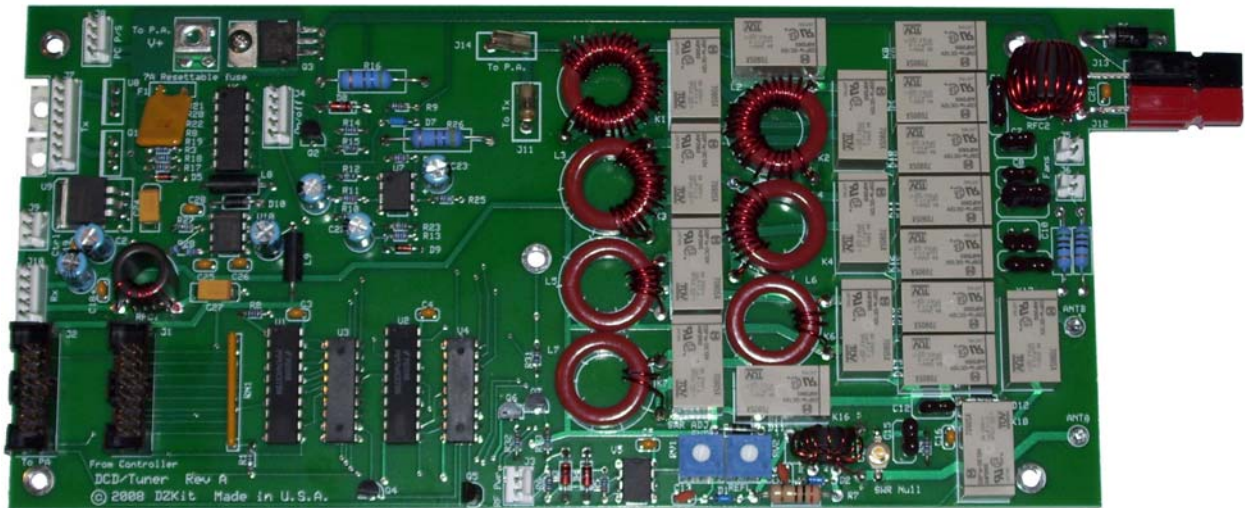

DCD Board, front, tuner section installed



## Appendix E-Front Panel Board

### PARTS LIST

Item	Part	Description	Qty
1	C1, C2	.1uF monolithic capacitor	2
2	C3	100uF/25V axial leaded electrolytic capacitor	1
3	RV1,RV3,RV5-RV12	10K 9mm snap-in pot	10
4	J2,J4	8-pin 2-row male header	2
5	J3, J5	16-pin 2-row male header	2
6	RN1,RN2	1K - 5 isolated resistor network	2
7	R4	100 ohm 1/4W resistor	1
7	R1,R2	1K ohm 1/4W resistor	2
8	S1-S14	NKK Lighted Pushbutton	14
9	S16	Rotary Encoder/switch	1
10	S15	SP8T Rotary switch	1
11	RV2,RV4	Trimpot 10K top adjust	2
12		Blank board	1

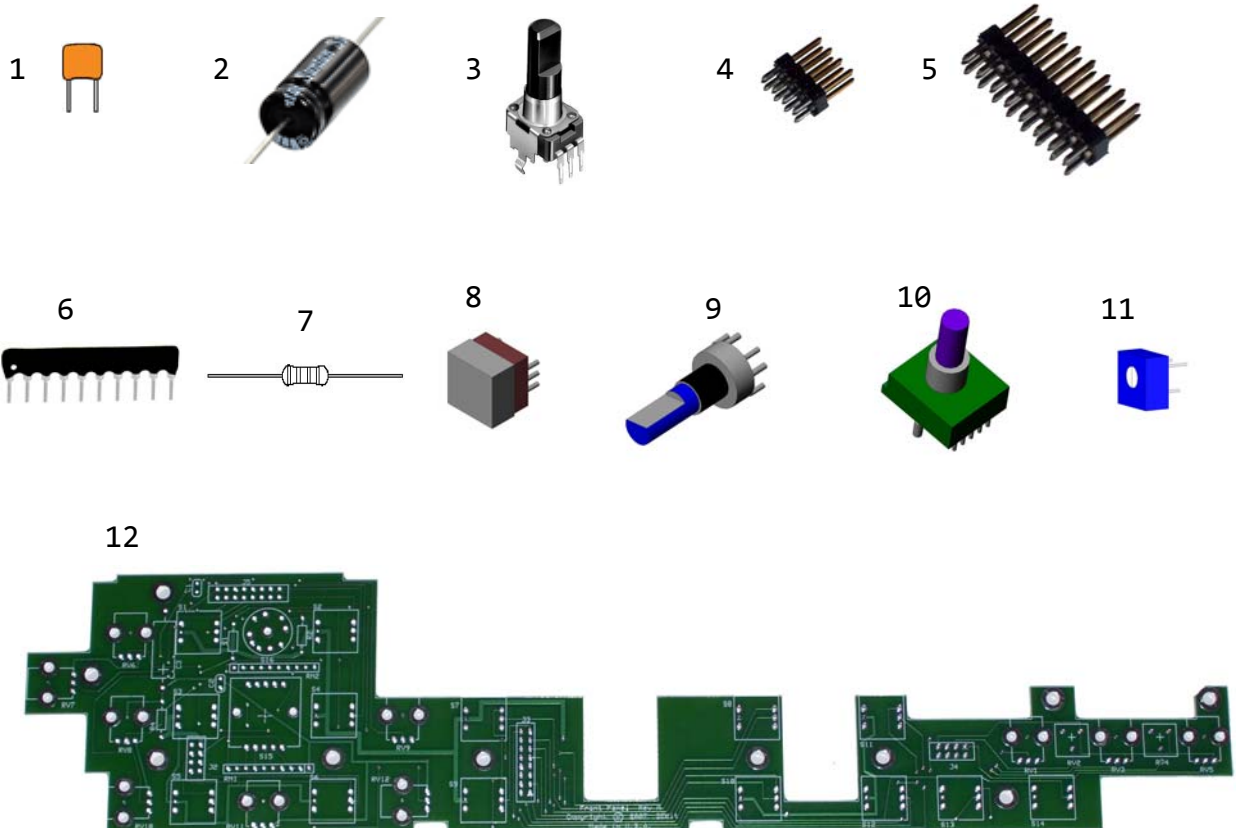



## STEP-BY-STEP ASSEMBLY-Front Panel Board

- ( ) Load all parts except the pushbutton switches and connectors. Use the silkscreening and/or ExpressPCB software to help you locate the parts.
- ( ) Mount all connectors to the back of the board - the non-silkscreened side; i.e., solder them on the top side. Make sure they are flat against the bottom side of the board.
- ( ) Insert the NKK pushbutton switches into the front panel board one at a time. Solder each one as it is installed before doing the next one. Be sure that the text on the back of the switch faces UP. There is a "+" symbol next to the middle pin on one side and a "-" symbol on the mid-

dle pin on the other side of the switch. The "+" side goes to the square pad. It is very important to get these right as the lights will not work if you get them reversed, and removing the switches is not trivial. *Tip: solder one pin while holding the board vertically, then lay it on a flat surface and heat that pin back up while you seat the switch on the board.* The plastic body must be absolutely flat and even. Be very careful not to touch the plastic switch covers with the soldering iron - they will melt. Replacement switches can be ordered from the factory for \$3.00 each, postpaid.

This completes assembly of the Front Panel board.

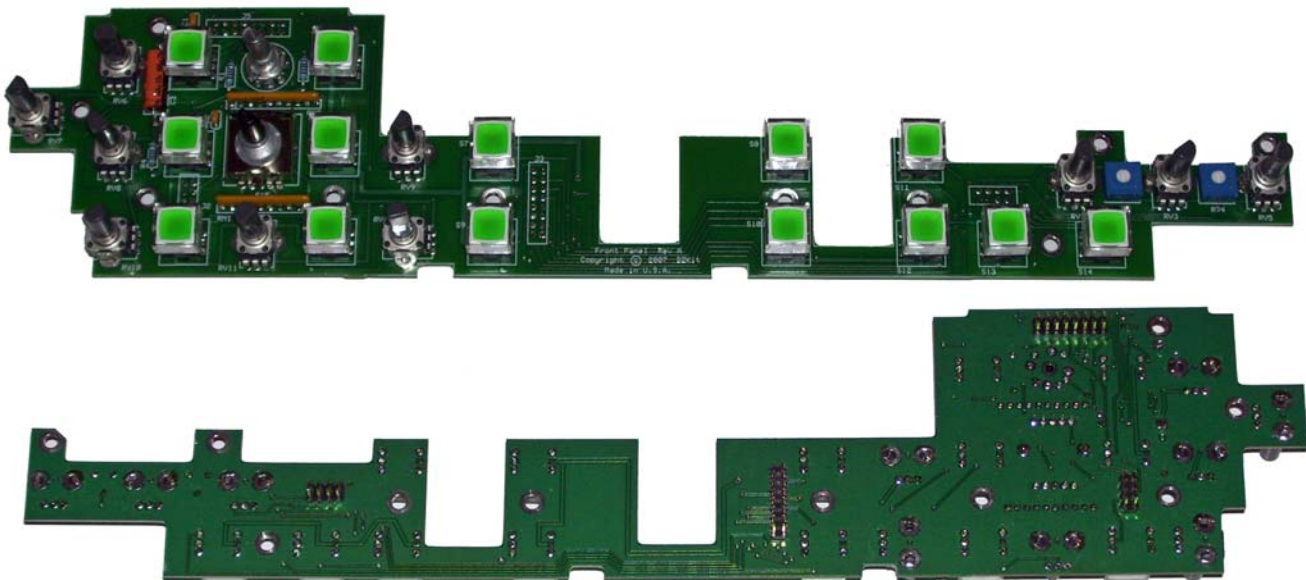



## Appendix F: IF Filter Board

### PARTS LIST

Item	Part	Description	Qty
1	C5,C6	27pF ceramic disk capacitor	2
1	C30-47	10pF ceramic disk capacitor	18
1	C3,C4,C7-C29,C48—70	.1uF ceramic disk capacitor	48
2	C1,C2	10uF/25V aluminum electrolytic, radial	2
3	D1-D36	1N914 signal diode	36
4	FL1	6.0KHz 9.0000 MHz crystal filter	1
5	FL2	LTM455DU +/-10KHz 455KHz ceramic filter	1
6	FL3	2.4KHz 10-pole 9.0015MHz filter on 'C' board	1
7	J1	8-pin male AMP MTA connector	1
8	J2,J3,J4,J5	Taiko-Denki RF jack PCB	4
9	J6-17	36-pin 1-row male tall pins (cut into 12 4-pin)	2
10	Q1-Q10	2N7000 MOSFET	10
11	R18	68	1
11	R21,R56-R63	150	9
11	R9,R12,R15	300	3
11	R13,R16	470	2
11	R14,R25,R28,R31,R34, R36	620	6
11	R8,R10,R19	1.2K	3
11	R5,R6,R7,R11,R17,R20, R23, R37, R38, R39	2.4K	10
11	R1,R2,R3,R4,R26,R29, R32,R35,R46-R55	10K	18
11	R22,R24,R27,R30,R33, R40-R45	20K	11
12	T1,T2	T2-1T 2:1 transformer, 6-pin DIP	2
12	T3,T4	T4-1 4:1 transformer, 6-pin DIP	2
12	T5,T6	T36-1 36:1 transformer, 6-pin DIP	2
13	U1	74HC139 dual 2-4 decoder	1
14	U2	74HC240 octal inverter	1
		Insulating sheet	1
15		Board lock 3/16" Nylon (Richco LCBSM-3-01)	12
16		Blank board	1

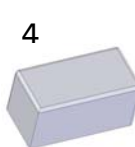

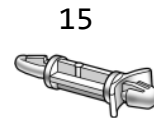
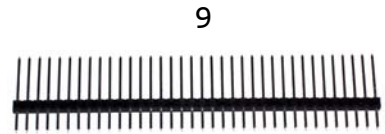
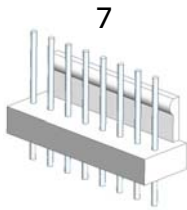

16

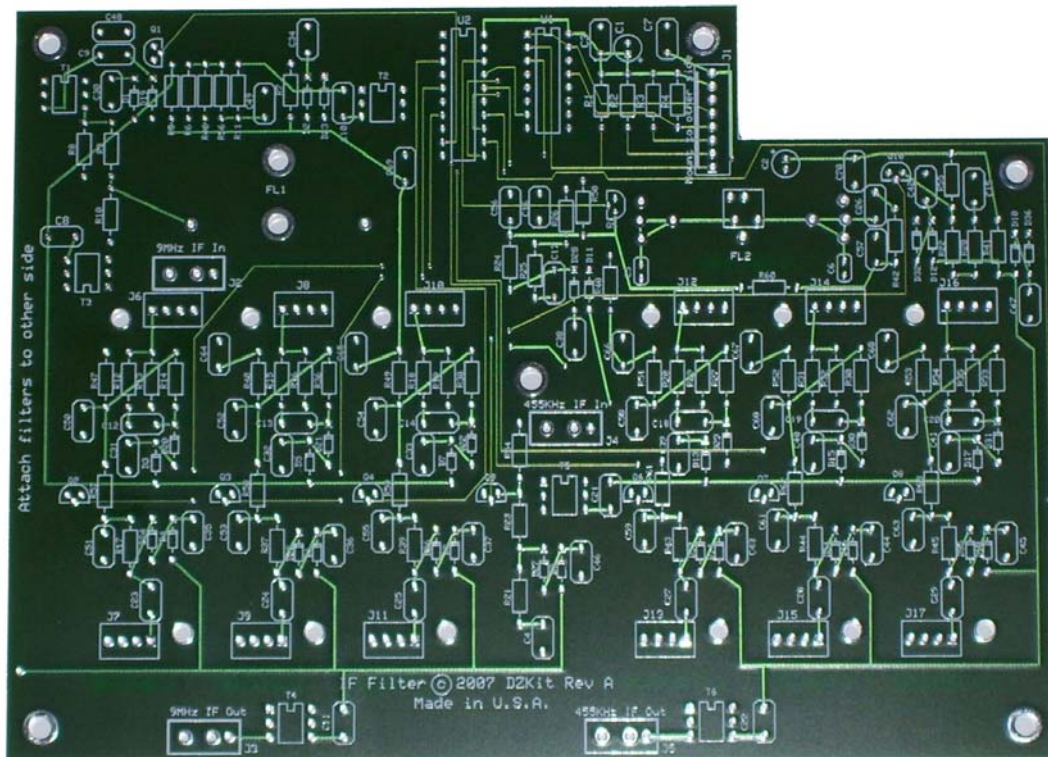



## STEP-BY-STEP ASSEMBLY-IF Filter Board

**IMPORTANT! ALL parts are mounted on the top (silkscreened) side of the board EXCEPT J1, all filters and the connectors that are formed out of the 36-pin, single row connector.**

**Highlight or check off each part on the bag label as you install it on the board. Unless otherwise instructed, load all parts of the same type from each bag and clip the leads after soldering.**

- ( ) Load and solder all 1N914 diodes. Make sure that the side with a band on it goes into the hole with a square pad. Clip the leads as close to the board as possible (called "close-clipping").
- ( ) Load and solder all capacitors. Make sure the electrolytic capacitors are loaded with the long (+) lead in the holes with square pads and marked on the silkscreen with a '+'. Close-clip the leads. Use silkscreened text and/or ExpressPCB to help you locate the parts.
- ( ) Load all resistors. Use silkscreened text and/or ExpressPCB to help you locate the parts.
- ( ) Load and solder transformers T1 and T2. These are marked T2-1T. Pin 6 (yes, pin 6) is marked with a dot. It must be loaded into the hole with the square pad.
- ( ) Load and solder transformers T3 and T4. These are marked T4-1.
- ( ) Load and solder transformers T5 and T6. These are marked T36-1.
- ( ) Load and solder IC's U1 and U2. Make sure that pin 1 goes in the hole with the square pad.
- ( ) Load and solder transistors Q1-Q10. Make sure the flat side of the transistor is lined up with the flat side of the silkscreened outline.
- ( ) Load and solder 4 Taiko-Denki RF connectors.
- ( ) Load connector J1 **on the bottom side of the board**. Make sure that the tab on the connector is on the side with the heavy bar on the silkscreen.

**Note: In the next three steps, you will load transformers. They look exactly the same but there**

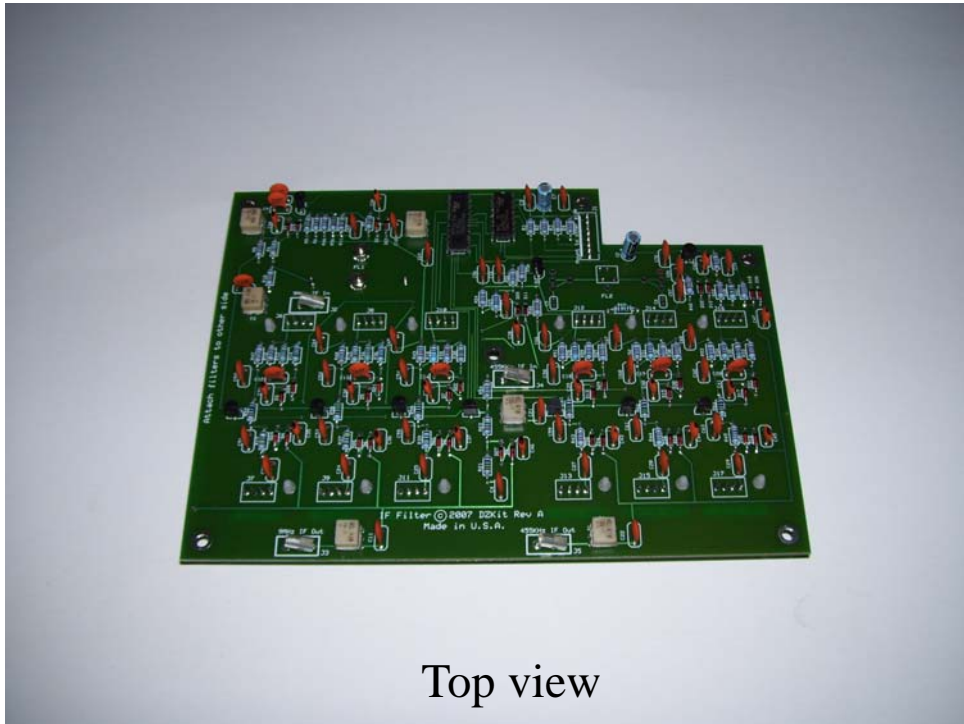

Top view

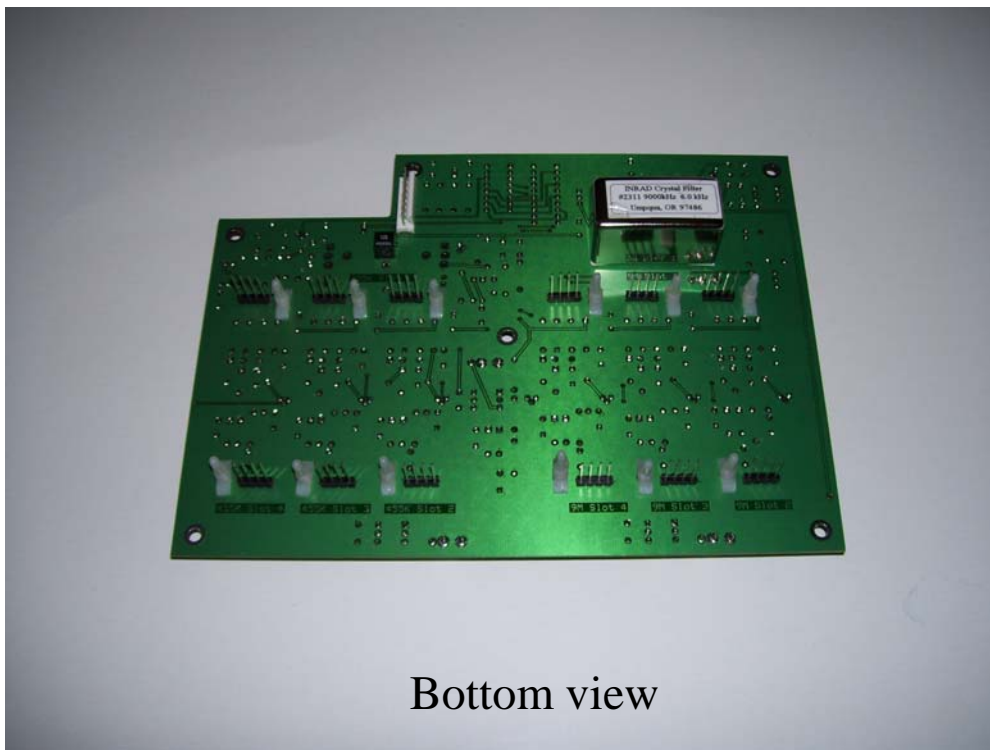

Bottom view

## IF Filter Photographs



- ( ) If you have purchased a 5.8KHz Collins mechanical filter for 455KHz, install it on the bottom side of the board in the location marked FL2.
  - ( ) If you have NOT purchased the Collins filter, load and solder the LTM455DU 20KHz ceramic filter in FL2 on the bottom side of the board.
  - ( ) Cut the 36-pin connectors into 12 4-pin connectors. (There will be extra pins left over.) Use wire cutters on the indented sections of the plastic. These connectors are very sharp. Be careful! Solder all 12 **to the bottom side of the board**. Disregard the square pad. See detail E1.
  - ( ) Locate the 9.0MHz 6KHz AM filter and the plastic sheet. Cut the sheet 1/8" larger than the size of the filter. Carefully punch holes in the plastic sheet at the location of the threaded tabs and the four pins. Push the sheet onto the filter, shiny side toward the filter, and place the filter on the board at FL1 **on the bottom side of the board**. Attach the nuts and lockwashers to the top side of the board. Solder all four pins. Clip the leads.
  - ( ) Push a Nylon fastener into each of the 12 holes located near the 12 4-pin connectors as shown in the bottom photo on page 89. Push the tabbed end into the board so that the tab compresses and lies flat against the board. You will hear a click as the tab locks into place.
  - ( ) After installation, you will add plug-in filters, including the 10-pole SSB filter that is included in this kit. Do not load it at this time, but set it aside in a secure place.
- This completes assembly of the IF filter board.

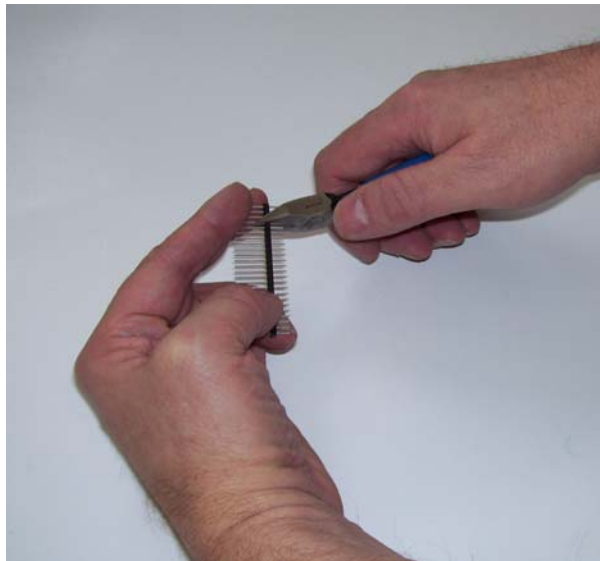

Detail E1. Cutting 36-pin connector into 12 4-pin connectors



## Appendix G: RXBPF Board

Item	Part	Description	Qty
1	C45, C48, C50	10pF ceramic disk or monolithic capacitor	3
1	C21	15pF ceramic disk or monolithic capacitor	1
1	C25	47pF ceramic disk or monolithic capacitor	1
1	C23	68pF ceramic disk or monolithic capacitor	1
1	C26	150pF ceramic disk or monolithic capacitor	1
1	C20	180pF ceramic disk or monolithic capacitor	1
1	C22, C24	220pF ceramic disk or monolithic capacitor	2
1	C9, C10, C11	.0015uF ceramic disk or monolithic capacitor	3
1	C16, C32-40, C43, C44, C47	.01uF ceramic disk or monolithic capacitor	13
1	C30, C31	.047uF ceramic disk or monolithic capacitor	2
1	C3-C8, C12-15, C17, C19, C28, C29, C41, C42, C46, C49	.1uF ceramic disk or monolithic capacitor	18
2	C1, C2	10uF/25V aluminum electrolytic capacitor	2
3	D1, D2	1N5223B-2.7V Zener diode	2
3	D3-8	1N4007B rectifier diode	6
4	J1	4-pin .1" centers male keyed header, right angle	1
5	J2, J3, J4	RF jack	3
6	J5	16-pin 2-row .1" centers r/a shrouded male header	1
7	K1, K2, K3	SPST 12V relay	3
8	K4, K5, K6	SPDT 12V relay	3
9	L7, L8	150nH SMT inductor	2
9	L5, L6	470nH SMT inductor	2
9	L2, L3, L4	1.5uH SMT inductor	3
9	L1	2.2uH SMT inductor	1
10	Q3, Q4	2N5109 RF transistor (metal can)	2
11	Q1, Q2, Q5, Q6, Q9, Q10	2N7000 MOSFET	6
11	Q7, Q8	MPSH10 NPN RF transistor	2
12	R12, R19, R30	4.75 ohm 1/8W resistor	3
12	R23-R29	27 ohm 1/8W resistor	7
12	R3, R5, R14, R21	51 ohm 1/8W resistor	4
12	R13, R20	100 ohm 1/8W resistor	2
12	R11, R18	470 ohm 1/8W resistor	2
12	R10, R17	680 ohm 1/8W resistor	2
12	R15, R22	1K ohm 1/8W resistor	2
12	R9, R16	2.7K ohm 1/8W resistor	2
12	R7, R8	4.7K ohm 1/8W resistor	2



Item	Part	Description	Qty
12	R1, R2	10K ohm 1/8W resistor	2
12	R4, R6	78.7K ohm 1/8W resistor	2
13	RFC1	1mH axial RF choke	1
14	RN1	Resistor network, 10-pin, 10K	1
15	S1	DPDT Switch	1
16	T1, T2	FT37-43 toroid	2
17	U1	74HC138 3-8 decoder	1
17	U2, U3	74HC174 6-bit flip-flop	2
18	U4	74HC374 8-bit flip flop	1
19	RX1-RX11	Receive Bandpass Filter Boards, partially assembled	11
20		Filter pin socket	22
21		4-40 x 3/16" hex M/F spacer	11
22		4-40 KEPS nut	11
23		4-40 x 3/16" PH M/S	11
24		Blank board	1

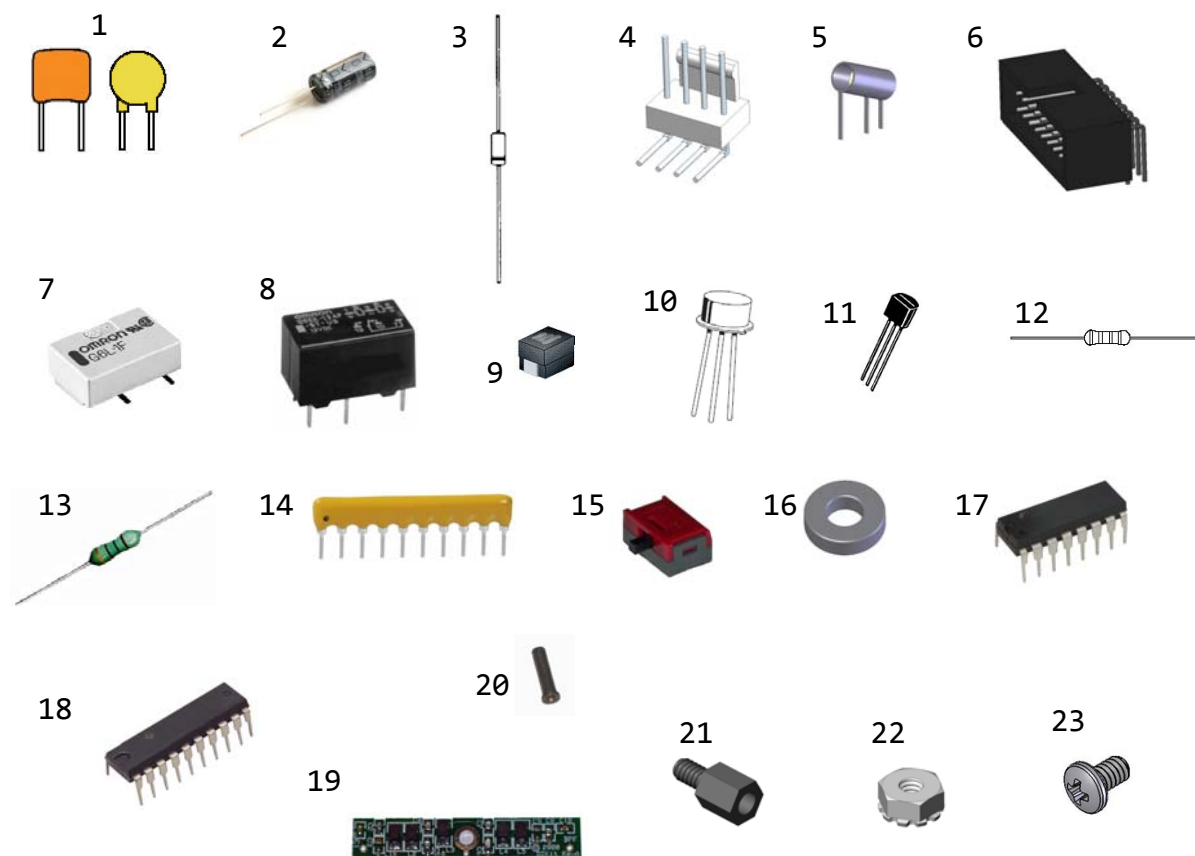



24

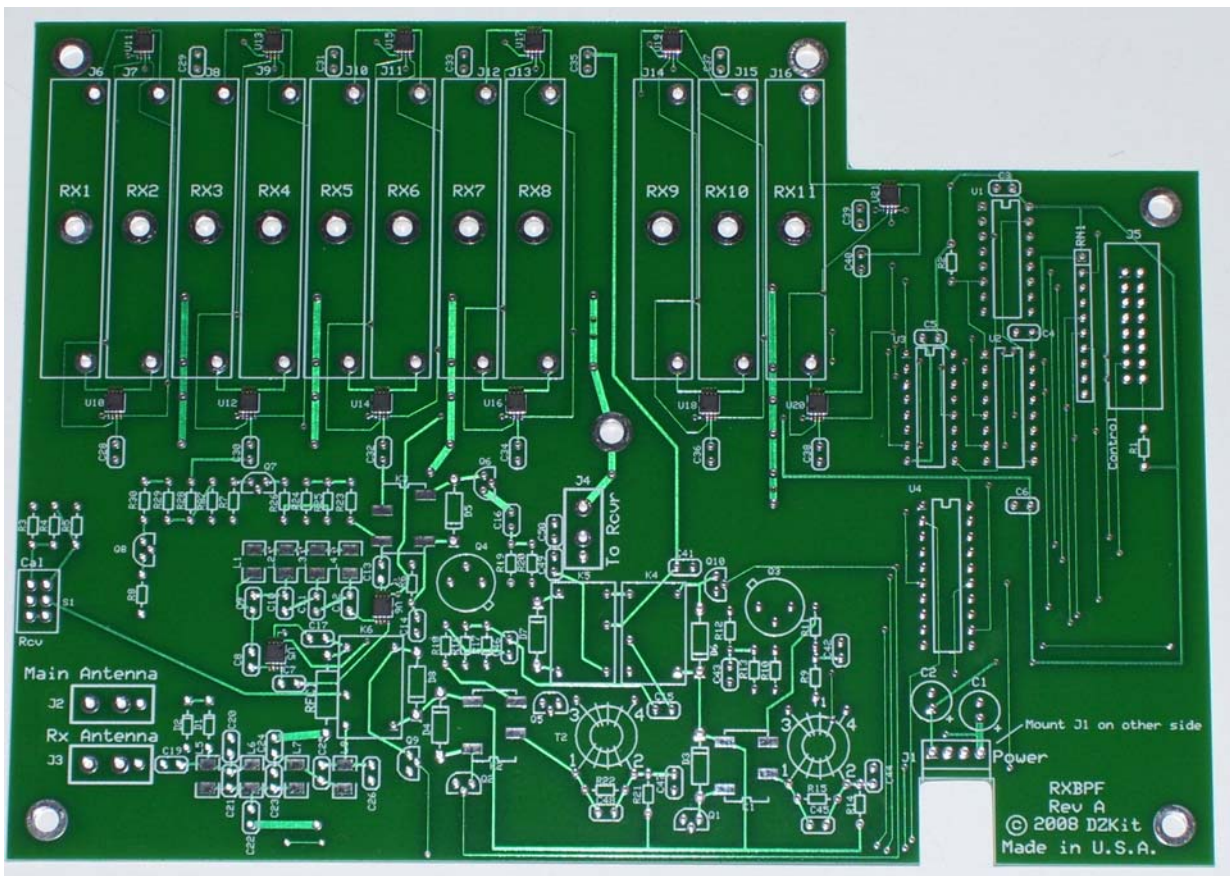

RXBPF board before loading, showing pre-loaded GaAsFET switches





## STEP-BY-STEP ASSEMBLY-RXBPF Board

*Highlight or check off each part on the bag label as you install it on the board. Unless otherwise instructed, load all parts of the same type from each bag. Solder the pins after you have installed a couple of bags of parts and then clip their leads. You do not want to do too many parts at once because you may miss some, and with too many leads, they can interfere with each other. When clipping leads, note whether parts move, indicating that they have not been soldered, and apply solder.*

- ( ) Remove the RXBPF board carefully from its antistatic bag. Observe static control precautions while loading this partially-loaded board. The GaAsFET switches that have been loaded are very sensitive devices and will have a direct effect on receiver performance if they are damaged. Be careful!
- ( ) Load and solder all capacitors. Make sure the two electrolytic capacitors are loaded with the long (+) leads in the holes with square pads and marked on the silkscreen with a '+'. Use silkscreened text and/or ExpressPCB to help you locate the parts. Note that all capacitor bags also contain resistors. Do not load the resistors until the next step.
- ( ) Load all resistors. Use silkscreened text and/or ExpressPCB to help you locate the parts. Note that some resistors are in the bag with diodes, and the rest are in the capacitor bags.
- ( ) Load and solder all diodes. Make sure that the side with a band on it goes into the hole with a square pad.
- ( ) Load all inductors. These are surface mount parts. To load a part, apply a small amount of solder to one of the pads on the board, then place the part on the pads and hold it in place with an awl, screwdriver or other small tool while applying heat to the same pad. When one side is soldered, solder the other side. Note that there are also transistors and/or ICs in the same bags. Save them for the next steps.
- ( ) Load the two metal transistors, Q3 and Q4. These transistors will only go in one way, and the tab on the side should be lined up with the silkscreened tab on the board. Insert the parts all the way down on the board.
- ( ) Load Q7 and Q8. Be sure to line up the flat side with



- the silkscreened outline on the board. Wiggle one pin into the hole, then twist the part gently until the other two pins can be inserted. Push the transistors down such that the bottom of the plastic body is about .1" off the board.
- ( ) Load the remaining six plastic transistors in the same manner as the previous step.
  - ( ) Load the resistor network, RN1. Be sure that pin 1, marked by a dot, goes into the hole with the square pad.
  - ( ) Load RFC1.
  - ( ) Load switch S1. Make sure that the switch lever extends out the side of the board.
  - ( ) Load relays K1-K3. These are surface mount relays. To load a part, apply a small amount of solder to one of the pads, then place the part on the pads (being careful to note the orientation) and hold it in place with a finger while applying heat to the same pad. When that pin is soldered and the relay is positioned inside the silkscreened outline, solder the other pins.
  - ( ) Load relays K4-K6. These will only go in one way.
  - ( ) Cut the magnet wire into four equal pieces, 6" each. Wind 10 turns around each side of each of the two toroids. See the photo of the finished board for reference. Remember that each pass of the wire through the toroid counts as one turn. Insert one toroid into the location marked T1 and the other into T2. Pull the leads tight and apply solder to each lead for at least one minute, rubbing the side of the wire with the iron frequently. Keep the heat on until shortly after you see the flux start to boil. Using an ohmmeter, Verify that there is continuity from pin 1 to pin 2, and pin 3 to pin 4, on each part after soldering. If not, apply more heat and re-measure.
  - ( ) Load all 22 filter pin sockets. To load, insert one row into the holes. Hold the board at an angle and solder each one from the bottom. Use an awl to hold each pin down while you heat the pin from the bottom of the board. Although it is not critical that these pins be precisely vertical, try to align all of the pins by sighting down the board as you install them. Be careful not to get solder inside the pins. Then repeat the procedure for the other row.



**Read the next two steps before proceeding:**

- ( ) Load all ICs. Before inserting each one into the board, verify that the name of the part that's printed on the IC matches the name on the bag label (e.g., 74HC138 - ignore other prefixes and suffixes). Do not solder them yet! Be sure that pin 1 of each IC is loaded in the square pad. Note that U1 is a 16-pin part as are U2 and U3. They are in different bags so that you can easily tell them apart. Be sure not to load U1 in the holes for U2 or U3, and vice versa. To keep the ICs in place before soldering, bend the corner pins over on the bottom side of the board.
  - ( ) Look at the ICs that you have loaded. Double check that no pins are bent under the parts, the right ICs are loaded in the right places and that pin 1 is on the square pad. When you are absolutely certain that the ICs are correctly loaded, solder all pins.
  - ( ) Load all connectors. ***J1, the 4-pin right-angle connector, mounts on the BOTTOM side of the board. ALL others mount on the top.***
  - ( ) Check your work. Run your finger over the parts on the top of the board gently to see if any parts are loose. Check IC orientation and electrolytic capacitor and diode polarity. Make sure all parts have enough solder but not too much. Make sure all parts are flush with the board. Check the bottom of the board for leads that may be touching other leads, and clip them closer to the board if necessary.
  - ( ) Attach 11 4-40 x 3/16" hex male/female standoffs in the center holes of the 11 filters (marked RX1-RX11). Use 4-40 KEPS nuts on the bottom of the board to secure them.
  - ( ) Cut the 36-pin male header into 22 1-pin pieces and discard the remaining 14-pin piece. Extra pins were included in case you have trouble with any of them.
  - ( ) Locate the 11 receiver band-pass filters (RX1-RX11). Attach two 1-pin connectors to each of the filters and cut each one to 1/4" as shown in Detail F1.
  - ( ) Place each filter in the location corresponding filter locations on the board and tighten each one with a 4-40 x 3/16" screw.
- This completes assembly of the RXBPF board.

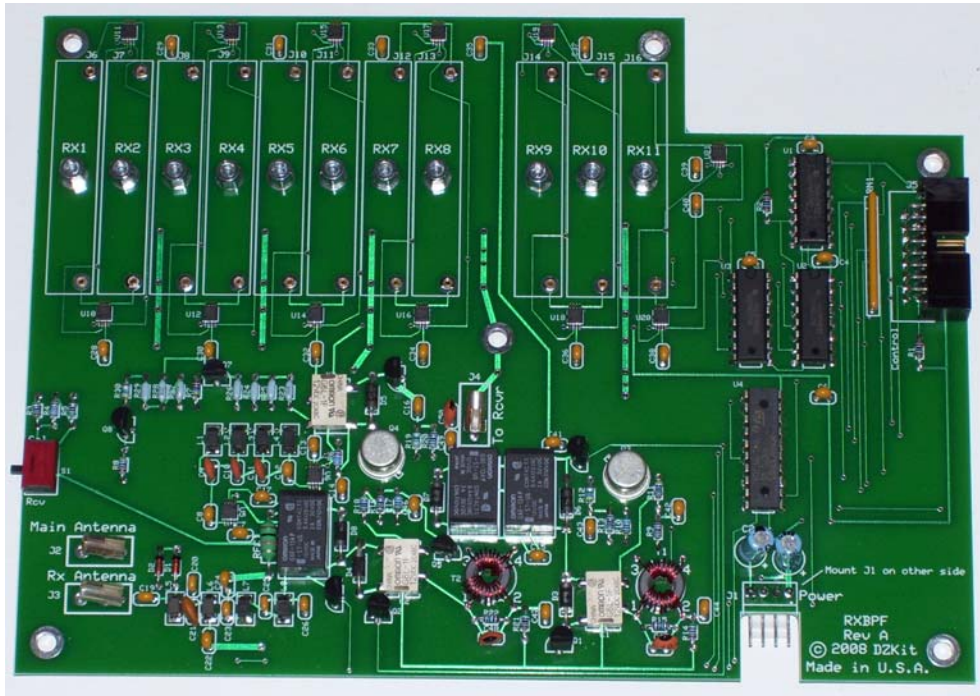

RXBPF board after loading, prior to insertion of BPF's

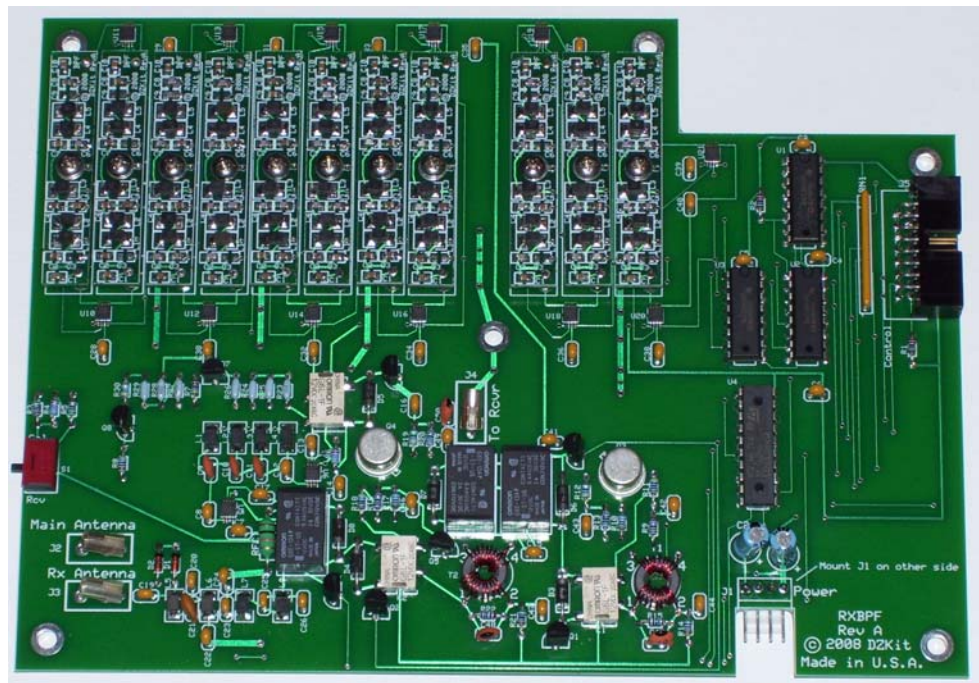

RXBPF board after loading and insertion of BPF's

Cut to 1/4"



Detail F1. BPF Assy



## Appendix H: Receiver Board

### PARTS LIST

Item	Part	Description	Qty
1	C73, C76, C90, C123, C124, C125, C136, C137, C138, C158	6-70pF trimmer capacitor	10
2	C4, C17, C24, C25, C26, C27, C93, C94, C106, C110	22uF/16V alum elec bi-polar	10
2	C1, C132, C161, C170	100uF/25V aluminum electrolytic	4
3	C60, C97	330uF/16V aluminum electrolytic	2
3	C103, C104	470uF/10V aluminum electrolytic	2
4	C40, C43, C59, C71, C74, C80, C89, C114, C150, C151	22uF/16V tantalum "B" size	10
5	C30	22uF/25V tantalum "D" size	1
6	D1, D2, D3, D4, D6, D7, D10, D13, D14, D15, D18	1N5711 Schottky diode	11
6	D8, D9, D11, D12	1N914 signal diode	4
7	FL1	70.455 MHz roofing filter	1
8	FL2, FL3, FL4	LTM455DU ceramic filter	3
9	J3	16-pin 2-row right-angle connector	1
10	J6, J19, J22, J25	2-pin male keyed connector	4
11	J12, J16, J20, J21, J23	3-pin male keyed connector	5
12	J5, J13, J24	4-pin male keyed connector	3
13	J10	8-pin male keyed connector	1
14	J1, J2, J7, J8, J9, J11, J14, J15, J17, J26	RF jack	10
15	L1, T3	FT50-61 toroid	2
16	L2	FT37-43 toroid	1
17	L7	1.2uH inductor, SMT	1
17	L8, L10, L11	100nH inductor, SMT	3
17	L13	150uH inductor, SMT	1
17	L4, L15	3.9uH inductor, SMT	2
17	L3	390nH inductor, SMT	1
17	L6, L14	680nH inductor, SMT	2
17	L12	68uH inductor, SMT	1

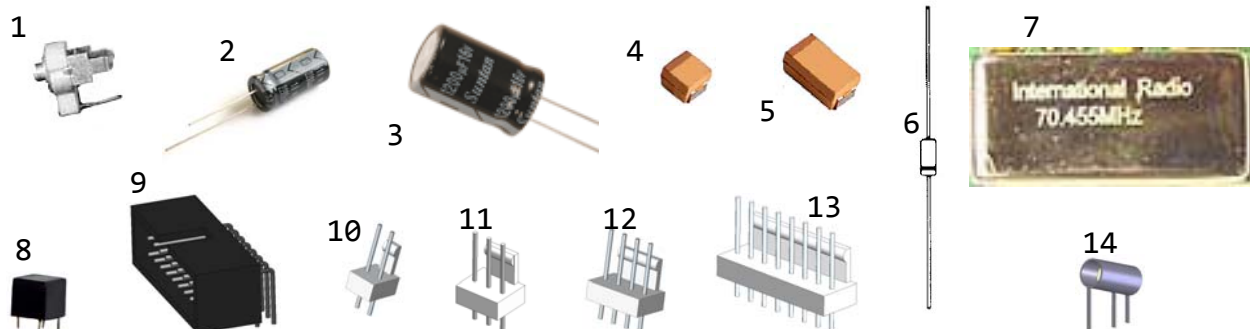



Item	Part	Description	Qty
17	RFC1, RFC2, RFC3, RFC4	1mH inductor, SMT	4
18	L5, L9	120uH variable inductor	2
19	RN1	Resistor network, 10K SIP	1
20	RV5	10K trimpot	1
20	RV2	100K trimpot	1
21	T2	T4-1 DIP transformer	1
21	T1, T4, T5, T6, T7	T36-1 DIP transformer	5
22	U31	LM2940CS-9 regulator TO-263	1
23	U18, U19	LM380 audio amplifier	2
24	U9, U12, U32	MC1350 IF amplifier	3
25	U6, U8	TUF-3 mixer	2
		Plastic insulating sheet	1
		Magnet wire, 24#	3'
26		Partially loaded board	1

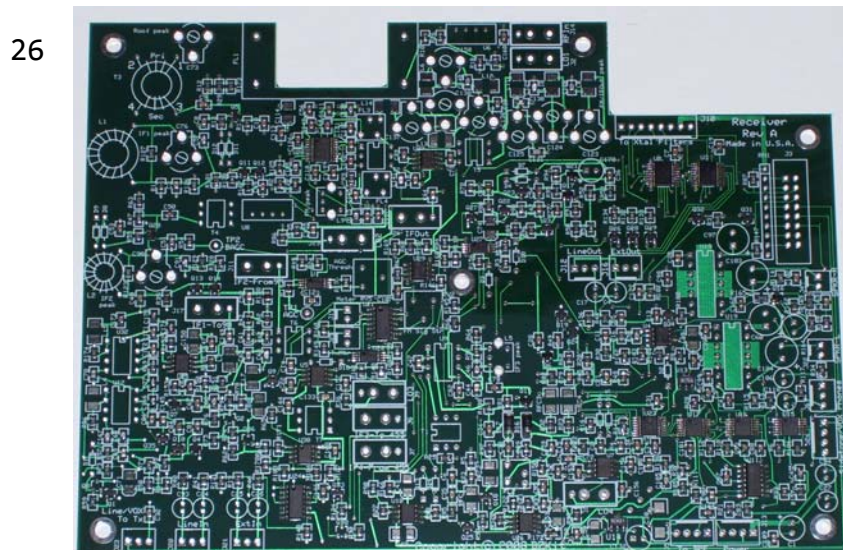



## STEP-BY-STEP ASSEMBLY-Receiver Board

*There are a lot of parts on this board. It can take quite a while for you to locate the parts visually. We highly recommend that you use the free ExpressPCB software to help you find the parts. Load the file receiver\_rev\_x.pcb (the x represents a revision letter).*

*Highlight or check off each part on the bag label as you install it on the board. Unless otherwise instructed, load all parts of the same type from each bag. Solder the pins after you have installed a couple of bags of parts and then clip their leads. You do not want to do too many parts at once because you may miss some, and with too many leads, they can interfere with each other. When clipping leads, note whether parts move, indicating that they have not been soldered, and re-solder them.*

- ( ) Remove the Receiver board from its antistatic bag. Handle this board with care and observe anti-static precautions to avoid damaging the pre-loaded parts.
- ( ) Load and solder all 70pF trimmer capacitors.
- ( ) Load and solder all 22uF/16V aluminum electrolytic capacitors flush with the board. These parts are bipolar – they can be installed in either direction even though one lead is longer.
- ( ) Load and solder the two 470uF/10V electrolytic capacitors and four 100uF/25V aluminum electrolytic capacitors flush with the board. Be sure to put the longer ('+') lead in the square pad, also marked with a '+' symbol. (The caps are very close together, and the '+' symbol can be interpreted as belonging to the wrong part, so be sure to look at the square pad!)
- ( ) Load and solder the two 330uF/16V electrolytic capacitors.
- ( ) Load and solder all "B" type tantalum electrolytic capacitors. These are surface mount devices. To load, apply solder to one pad on the board, then place the part on the pad, holding it in place with a small tool. Heat the part and pad until the solder flows, coating the pin, then do the other side. The side with the "bar" on it must be lined up with the side of the silkscreened component outline with angled corners.
- ( ) Load U31, a 9V regulator on the bottom of the board. This is an SMT device. To load,



place the part on the pads and solder one pin while holding the device in place. Then solder the other two pins. Apply solder to the tab along the top edge and keep the heat on until the solder flows freely around the tab. On the top side, apply solder to the five holes that are located in the center of the tab area.

- ( ) Load C30, the “D” type tantalum electrolytic capacitor. Be sure to observe proper polarity.
- ( ) Load and solder all SMT inductors and RFC1-4 (also SMT parts) in the same manner as the SMT capacitors. There is no polarity to these parts, so they may be loaded in either direction.
- ( ) Load and solder all 1N5711 and 1N914 diodes. Be sure that the side with a band goes into the hole with a square pad.
- ( ) Load and solder FL2, FL3 and FL4, 20KHz ceramic filters.
- ( ) Load and solder L5 and L9, the two variable inductors.
- ( ) Load and solder resistor network RN1. Be sure that the dot marking pin 1 goes into the hole with the square pad.
- ( ) Load and solder the two trim-pots, RV2 and RV5. The value of these pots is marked on the side. Be sure to put the 10K pot (marked 103) in the holes for RV5. The 100K pot (marked 104) goes into RV2.
- ( ) Load and solder T2, a Minicircuits T4-1 transformer. Pin 6 is marked by a dot. This pin goes in the hole with the square pad. *The other 6-pin transformers look exactly like this one. Make sure you load the T4-1 transformer into T2.*
- ( ) Load and solder five T36-1 Minicircuits transformers. Pin 6 is marked by a dot. This pin goes in the hole with the square pad.
- ( ) Load and solder U6 & U8, TUF-3 RF mixers. Make sure the body is oriented so that it does not extend beyond the silkscreened outline.
- ( ) Load and solder the two LM380 audio amplifier ICs, U18 and U19. Be sure that pin 1 goes into the hole with the square pad.
- ( ) Load and solder U9, U12, and U32, the NTE746 IF amplifier ICs. Be sure that pin 1 goes into the hole with the square pad.



- ( ) Locate the small toroid. Cut a 3" length of magnet wire. Wind 3 turns of magnet wire around this toroid. Each time the wire passes through the center is considered 1 turn. Leave about 1/2" of lead extending out from the toroid. Load this toroid into L2. Solder the leads, keeping the soldering iron (set to 750 degrees F) on the leads until the coating melts away and the solder flows onto both the pad and the wire smoothly. This can take about one minute per lead.
- ( ) Locate the other two larger toroids. Cut a 3" length of magnet wire and wind one toroid with 3 turns. Leave about 1/2" of lead extending out from the toroid. Load it into L1. Solder the leads as described in the previous step.
- ( ) Cut a 10" length of magnet wire. Wind 13 turns completely around the remaining toroid. Then cut a 3" length of magnet wire and wind 3 turns on top of the side of the toroid that does not have leads extending out from it. Solder the four leads at T3. The side with 3 turns goes into the holes marked Primary (pins 1 and 2).
- ( ) Clip excess leads from the toroid wires. Apply a small dab of glue to each toroid to hold it in place.
- ( ) Using an ohmmeter, verify that there is continuity (<1 ohm) from pins 1 to 2 and from 3 to 4 on T3, and from one lead to the other on inductors L1 and L2. If not, apply more heat to the leads and re-measure.
- ( ) Load all white AMP MTA connectors. Be sure the tab lines up with the heavy line on the silkscreened outline. Load these connectors one at a time by holding the board vertically while pushing the part flat against the board with a fingernail on one side of the connector and soldering a pin on the other side of the connector to avoid burning your finger. Then solder the other pins. Do not apply too much heat to avoid causing the pins to slip inside the connector.
- ( ) Load and solder J3, a right-angle 16-pin ribbon cable connector. Pin 1 on this connector is marked with an embossed triangle. Be sure this pin goes into the hole with the square pad.
- ( ) Load and solder the 10 RF connectors.
- ( ) Cut two 1/4" squares of plastic sheet and puncture the center with an awl, or small



knife or screwdriver. Place the squares over the two ungrounded pins of the 70.455MHz roofing filter. The ungrounded pins are the two that are not directly connected to the metal body. Load and solder the filter.

are inserted correctly, that pin 1 of the ICs and resistor network are on the square pads, and that all parts are soldered. Also check to be sure that all leads are clipped and not shorting other leads.

( ) Check your work carefully. Make sure all polarized parts

This completes assembly of the Receiver board.

Completed receiver board – top view

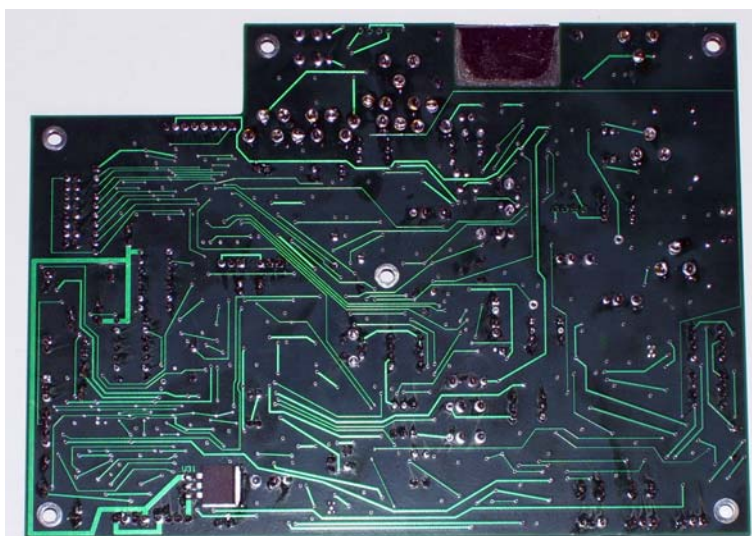
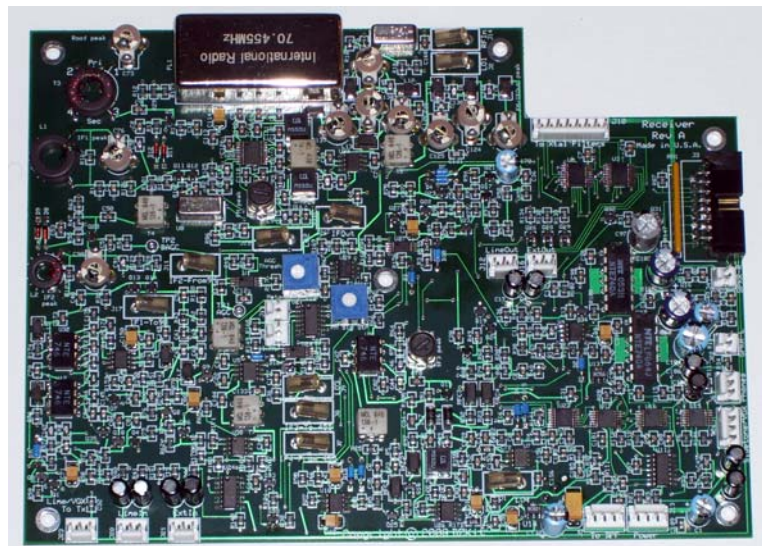

Completed receiver board – bottom view



## Appendix I: Transmitter Board

### PARTS LIST

Item	Part	Description	Qty
1	C108	18pF silver mica (sm)	1
1	C86	20pF sm	1
1	C103	27pF sm	1
1	C112	33pF sm	1
1	C110	47pF sm	1
1	C105	56pF sm	1
1	C95, C107	68pF sm	2
1	C85	82pF sm	1
1	C40, C89	100pF sm	2
1	C106	120pF sm	1
1	C101, C109, C111	150pF sm	3
1	C36	220pF sm	1
1	C49, C55, C104	270pF sm	3
1	C13, C39, C56, C87, C90, C91	330pF sm	6
1	C38, C88	390pF sm	2
1	C59, C99	560pF sm	2
1	C11	1000pF sm	1
1	C34, C41	1200pF sm	1
1	C37	2200pF sm	1
2	C48, C74	2.2uF/10V tantalum "A"-size (SMT)	2
3	C69, C72, C75, C78, C114, C115, C127	22uF/16V tantalum "B"-size (SMT)	7
4	C47, C63	22uF/25V tantalum "D"-size (SMT)	2
5	C84, C121, C122	22uF/16V bi-polar aluminum electrolytic	3
6	C2, C30, C82, C96, C139	10uF/25V aluminum electrolytic (SMT)	5
6	C1, C116	100uF/25V aluminum electrolytic (SMT)	2
7	D14, D27	1N914 signal diode	2
7	D24, D26	1N5231B 5.1V Zener diode	2



2



3



4



5



6



7





Item	Part	Description	Qty
8	R73	.05 ohm 2W sense resistor (SMT)	1
9	R56	1.5 ohm 1W power resistor (SMT)	1
9	R85	50 ohm 1W power resistor (SMT)	1
10	R4, R5	330 ohm .3W power resistor (SMT)	2
11	R27	75 ohm 1W power resistor	1
12	R39	180 ohm 1W axial power resistor	1
13	J1	16-pin 2-row .1" centers shrouded male header	1
14	J3, J4, J15	2-pin AMP MTA male keyed header	3
15	J6, J18	3-pin AMP MTA male keyed header	2
16	J14	4-pin AMP MTA male keyed header	1
17	J5	5-pin AMP MTA male keyed header	1
18	J13, J17	4-pin 2-row female bd mt socket	2
19	J12, J16	8-pin 2-row female bd mt socket	2
20	J2	8-pin DIN PC-mt	1
21	J8, J9, J10, J11	RF Jack	4
22	J7	Kobiconn triple phono connector	1
23	F1	250mA axial fuse	1
24	K1-K10, K14	SPST 12V SMT relay	11
25	K11	DPDT 12V relay	1
26	K12, K13	SPDT 12V relay	2
27	L1, L2, L3, L4	T50-2 toroid (red)	4
28	L5-L12	T50-10 toroid (black)	8
29	L13, L14	Ferrite Bead	4
30	L15	0.68uH inductor (SMT)	1
30	L16-L22	82uH inductor (SMT)	7
30	RFC3-6	10uH inductor (SMT)	4
30	RFC1, RFC2	100uH inductor (SMT)	2

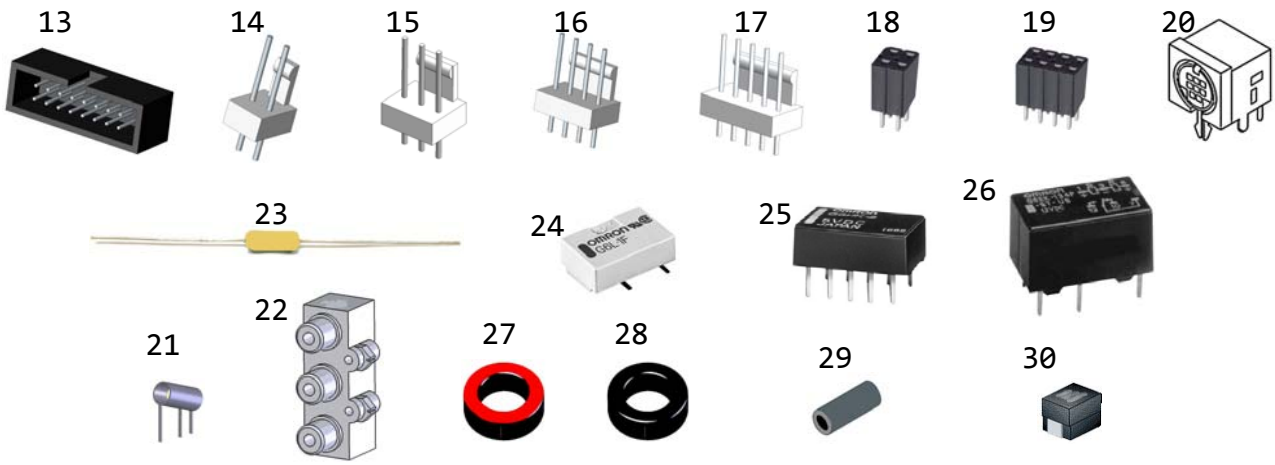



Item	Part	Description	Qty
31	Q2, Q7, Q9, Q12, Q15,	2N3904 NPN transistor	7
31	Q19, Q26, Q36	2N3906 PNP transistor	3
31	Q21	J310 JFET	1
31	Q24	MPSH10 low capacitance NPN transistor	1
31	Q1, Q2, Q8, Q10, Q16, Q17, Q20, Q22, Q23, Q28, Q29, Q33, Q34,	2N7000 N-channel MOSFET	15
32	Q4, Q5	2SC1969 NPN RF power transistor	2
32	Q3	2SC2166C NPN RF power transistor	1
32	Q13	TIP31A NPN power transistor	1
33	Q11	FQB9N15TM N-channel MOSFET (SMT)	1
33	U18	LM2940CS-10 10V regulator (SMT)	1
34	Q14	2N5109 NPN low-noise RF transistor	1
35	RN1	Resistor network, 10-pin 10K ohm	1
36	RV1	1M trimpot - vertical	1
37	T1, T3	FT37-43 toroid	2
38	T5	Binocular core	1
39	T4	FT50-43	1
40	T2, T6, T7	T36-1 6-pin transformer	3
41	TH1	Thermistor - 10K ohm	1
42	U10	TUF-3 RF mixer	1
43	Y1-Y14	4.9152MHz Crystal	14

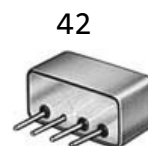
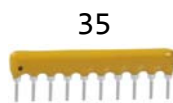



Item	Part	Description	Qty
44		Heatsink - 2.5" x 4.5", black anodized	1
45		Hex M/F spacer - 4-40 x 3/16"	14
46		Thermasil sticky-back insulator	4
47		Screw - 4-40 x 3/16" PH Phillips M/S	6
48		Fiber shoulder washer	4
		Insulated hookup wire	6"
		#24 magnet wire	140"
		#26 magnet wire	36"
49		Partially loaded Transmitter Board	1

44

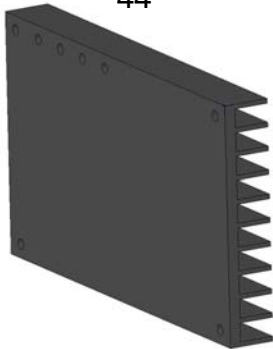

45



46



47



48



49

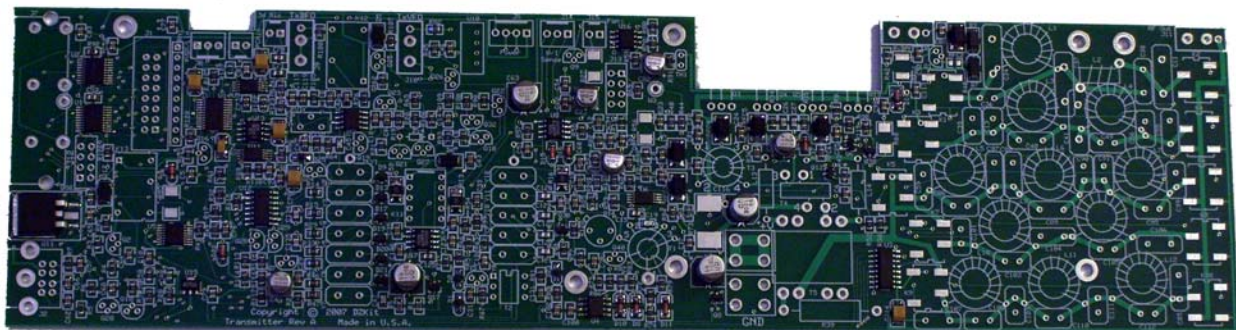



## STEP-BY-STEP ASSEMBLY-Transmitter Board

- ( ) *Remove the transmitter board from its antistatic bag. Handle this partially assembled board carefully and observe antistatic precautions to avoid damaging the board.*
- ( ) Load and solder all 10 surface mount relays, K1-K10. To solder relays, follow this procedure: Add a small amount of solder to any pad. Place the relay into position with all pins centered on the pads. Re-heat the pad you just added solder to while holding the relay in place. Once it is soldered securely, solder the other pins. Be sure to do this step first, as it is hard to reach some of the relay pins once the toroids are in place.
- ( ) Load and solder relay K11. Be sure that the side with a white bar printed on top lines up with the white bar on the silkscreened outline.
- ( ) Load and solder relays K12 and K13.
- ( ) Load and solder diode D14. Be sure that the side with the band goes into the hole with a square pad. Clip the leads.
- ( ) Load and solder all 2N3904 NPN transistors. Be sure the flat side lines up with the flat side of the silkscreened outline. Clip the leads.
- ( ) Load and solder all 2N3906 PNP transistors. Be sure the flat side lines up with the flat side of the silkscreened outline. Clip the leads.
- ( ) Load and solder Q14, a 2N5109 RF transistor, flush with the board. Clip the leads.
- ( ) Load and solder all 2N7000 N-channel MOSFETs. Be sure the flat side lines up with the flat side of the silkscreened outline. Clip the leads.
- ( ) Load and solder Q11. Place this SMT part on the pads and solder one pad while holding the part to keep it from moving. Then solder the other pin(s). Some of these parts have 3 pins, some have 2. Finally, solder around the edges of the metal tab.
- ( ) Load and solder Q21, a J310 JFET. Be sure the flat side lines up with the flat side of the silkscreened outline. Clip the leads.
- ( ) Load and solder Q24, a low capacitance MPSH10 NPN RF transistor. Be sure the flat side lines up with the flat side of the silkscreened outline. Clip the leads.



- ( ) Load and solder resistor network RN1. Be sure that pin 1, marked with a dot, goes into the hole with the square pad.
- ( ) Load and solder trimpot RV1. Clip the leads.
- ( ) Load and solder U10, a TUF-3 RF mixer. Make sure the body is oriented so that it does not extend beyond the silk-screened outline. Clip the leads.
- ( ) Load and solder Y1-Y12, 4.915MHz crystals. Clip the leads.
- ( ) Load all connectors. Be sure to line up the tabs on the white AMP MTA connectors with the silkscreened bar. Make sure the embossed triangle on the 16-pin connector goes into the square pad. ***J12 and J13 mount on the back side of the board.***
- ( ) Locate the four red toroids. Cut the magnet wire into 12 lengths as shown in the table below. Wind the specified number of turns of magnet wire around each toroid. Each time the wire passes through the center is considered 1 turn. Leave about 1/2" of lead extending out from the toroid. Load these toroids into L1-L4. Note that L2 stands up while the others lay flat on the board. Solder the leads, keeping the soldering iron (set to 750 degrees F) on the leads until the coating melts away and the solder flows onto both the pad and the wire smoothly. This can take about one minute per lead. Clip the leads.
- ( ) Repeat the previous step with the eight black toroids. Load and solder these toroids into L5-L12. Clip the leads.
  - L1: 27 turns (18")
  - L2: 25 turns (17")
  - L3: 14 turns (10")
  - L4: 13 turns (10")
  - L5: 13 turns (10")
  - L6: 12 turns (9")
  - L7: 12 turns (9")
  - L8: 11 turns (8")
  - L9: 10 turns (7")
  - L10: 9 turns (7")
  - L11: 8 turns (6")
  - L12: 8 turns (6")
- ( ) Load and solder all silver mica capacitors. Clip the leads. Save two of the large diameter leads.
- ( ) Place two ferrite beads over a clipped lead from the previous step. Bend the ends of the wire down so that the resulting inductor fits in the holes for L13. Load and solder this part and clip the leads.
- ( ) Repeat the previous step for inductor L14.
- ( ) Load and solder a T36-1 transformer at T2, T6 and T7.



- Pin 6 is marked with a dot and goes in the hole with the square pad.
- ( ) Wind 9 turns (cut 10") of red 24# magnet wire completely around a red FT37-43 toroid. Wind 3 turns (4") of green 28# magnet wire around the other side. Leave 1/2" of all leads extending from the toroid. Load and solder the toroid at T1 using procedures described in detail in previous steps. The 9 turn side goes in holes marked 1 and 2. Clip the leads.
  - ( ) Wind 12 turns (13") of red 24# magnet wire completely around a red FT37-43 toroid. Wind 8 turns (9") of green 28# magnet wire around the other side. Leave 1/2" of leads extending from the toroid. Load and solder the toroid in transformer T3 using procedures described in detail in previous steps. The side with 12 turns goes in the holes marked 1 and 2. Clip the leads.
  - ( ) Twist together two 6" lengths of red and green magnet wire, about 2 turns per inch. Wind 5 turns completely around a black FT50-43 toroid. Solder the toroid leads at T4 using procedures described in detail in previous steps. The red leads go in the holes marked 1 and 2. Clip the leads.
  - ( ) Locate the gray binocular core. Wind 2 turns of magnet wire in the center holes and leave 1" extending out from the body of the core. Wind 3 turns of magnet wire from the other side and leave about 1" extending out from the body facing the other direction. Load the core at T5, with the 3 turn winding facing toward the bottom of the board. Solder the toroid leads using procedures described in detail in previous steps. Clip the leads.
  - ( ) Feed a two 2" lengths of magnet wire through the outer holes in the core and into the pads at the edges of the core, one on each side. Solder the leads using procedures described in detail in previous steps. Clip the leads.
  - ( ) Load and solder R29, a 1W 180 ohm power resistor. Clip the leads.
  - ( ) Insert and tighten four 4-40 x 1/4" hex male/female stand-offs in the four threaded mounting holes in the heatsink. Refer to Pictorial H1.
  - ( ) [Read the next 5 steps before doing any of them.](#)
  - ( ) Place the four power transistors on the heatsink as shown in the Pictorial in the order shown. Insert a 4-40 x 3/8"



screw through the mounting holes and into the threaded holes in the heatsink. **Do not tighten the screws.**

- ( ) Place the heatsink under the board so that the four mounting holes line up with those on the PC board. Note where the power transistor leads need to be bent up to fit in their holes. Remove the heatsink and bend the transistor leads up at that point. Remove the screws and insert the transistors in their holes on the PC board. **Do not solder them.**
- ( ) Line up the heatsink mounting holes with the mounting holes on the board and secure it with four 4-40 x 1/4" screws.
- ( ) Place a mica insulator under each of the four power transistors so that the large hole in the insulator lines up with the transistor mounting hole. Insert a fiber shoulder washer into each transistor's mounting hole. Gently wiggle the transistors so that the holes line up perfectly with the corresponding threaded holes in the heatsink. Insert a 4-40 x 3/8" screw through the washer, transistor, insulator and into the heatsink. Screw them in snugly but do not over-tighten them. Make sure as you do this that the screw goes in smoothly without any difficulty and that the shoulder washers remain fully inserted in the transistor mounting holes. If you encounter resistance, back off on the screw, re-seat the washer, check to make sure the hole is centered and try again.
- ( ) Solder the transistor leads. Clip off any excess lead length.
- ( ) Insert thermistor TH1 from the back side of the board so that it touches the heatsink. Solder the leads on the top side of the board. Clip the leads.
- ( ) On the back side of the board, solder a 6" insulated wire between the two pads labeled XVT.
- ( ) Build the TXBPF board (Appendix J).
- ( ) Push the TXBPF board onto connectors J12 and J13 with the notch in the board lined up with the notch in the top of the transmitter board. Secure the board with two 4-40 x 1/4" screws.
- ( ) Check your work carefully. Look for unsoldered connections, especially around toroid leads, shorts, unclipped leads, loose screws, backwards ICs and misloaded transistors and connectors.

This completes assembly of the Transmitter.

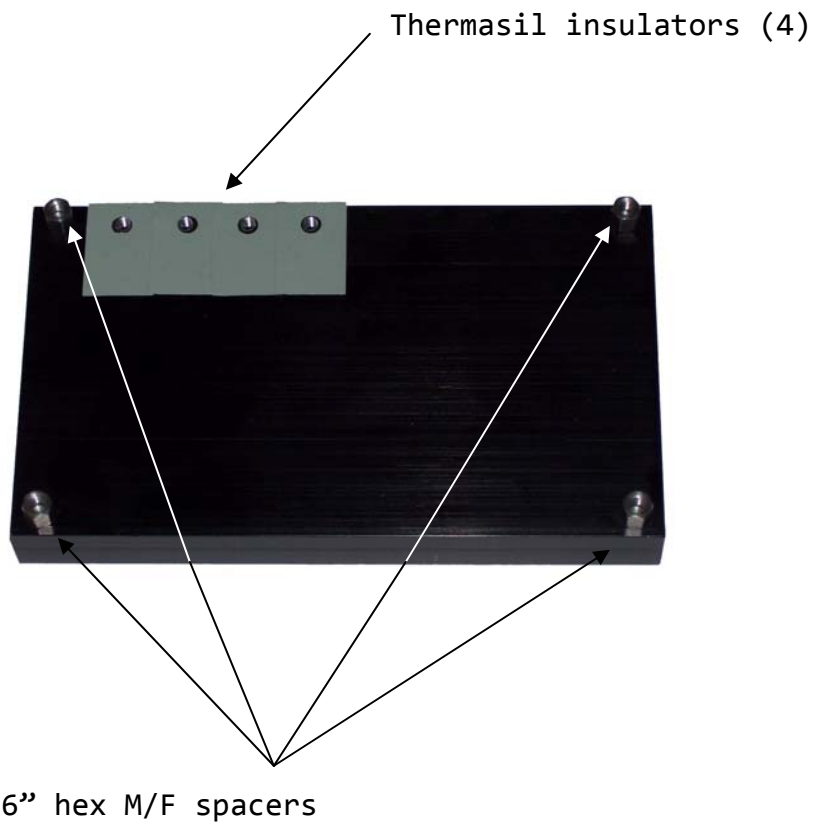

Pictorial H1. Transmitter heatsink

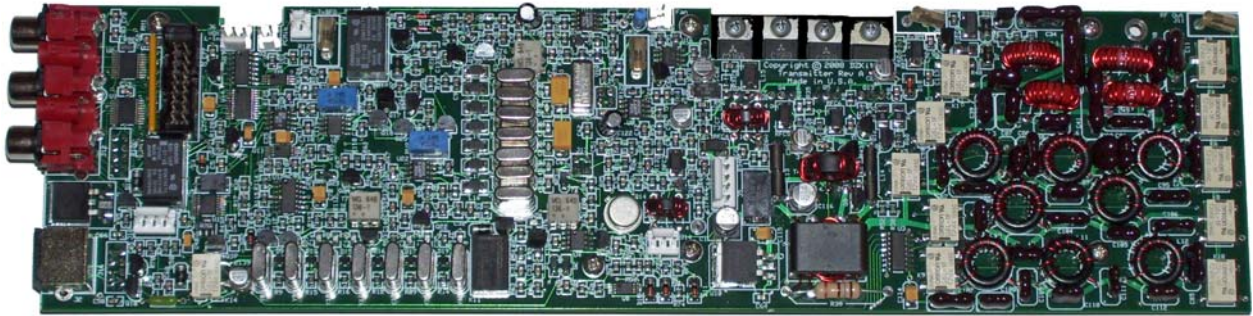

Transmitter board, after construction, top

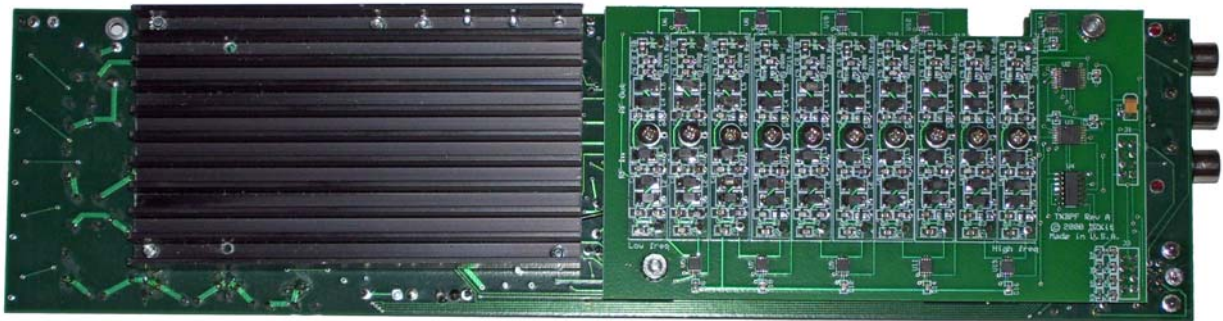

Transmitter board, after construction, bottom



# Appendix J: TXBPF Board

## PARTS LIST

Item	Part	Description	Qty
1	J1, J3	8-pin 2-row male header	2
2	J2, J14	4-pin 2-row male header	2
3		BPF TX1	1
3		BPF TX2	1
3		BPF TX3	1
3		BPF TX4	1
3		BPF TX5	1
3		BPF TX6	1
3		BPF TX7	1
3		BPF TX8	1
3		BPF TX9	1
3		BPF TX10	1
4		Filter pin socket	20
5		4-40 x 7/16" hex M/F spacer	2
6		4-40 x 3/16" hex M/F spacer	10
7		4-40 KEPS nut	12
8		4-40 x 3/16" PH M/S	10
9		Blank board	1

1



2



3



4



5



6



7



8







## STEP-BY-STEP ASSEMBLY-TXBPF Board

- ( ) Remove the TXBPF board carefully from its antistatic bag. Observe static control precautions while loading this partially-loaded board. The GaAsFET switches that have been loaded are very sensitive devices and will have a direct effect on transmitter performance if they are damaged. Be careful!
- ( ) Load all 20 filter pin sockets. To load, insert one row into the holes. Hold the board at an angle and solder each one from the bottom. Use an awl or other sharp tool to hold each pin down while you heat the pin from the bottom of the board. Although it is not critical that these pins be precisely vertical, try to align all of the pins by sighting down the board as you install them. Be careful not to get solder inside the pins. Then repeat the procedure for the other row.
- ( ) *Load all connectors on the BOTTOM side of the board. Be sure they are mounted flat against the board.*
- ( ) Attach ten (10) 4-40 x 3/16" hex male/female spacers in the center holes of the 10 filters (marked TX1-TX11). Use 4-40 KEPS nuts on the bottom of the board to secure them.
- ( ) Cut the 36-pin male header into 20 1-pin pieces and discard the remaining 16-pin piece. Extra pins were included in case you have trouble with any of them.
- ( ) Locate the 10 transmitter bandpass filters (TX1-TX11). Attach two 1-pin connectors to each of the filters and cut each one to 1/4" as shown in Detail J1. Make sure they are mounted as straight as possible.
- ( ) Place each filter in the location corresponding filter locations on the board and tighten each one with a 4-40 x 3/16" screw.
- ( ) Insert the male threads of two 4-40 x 7/16" hex male/female spacers from the back side of the board into the corner mounting holes and secure them on the front of the board with two 4-40 KEPS nuts.

This completes assembly of the TXBPF board.



TX1

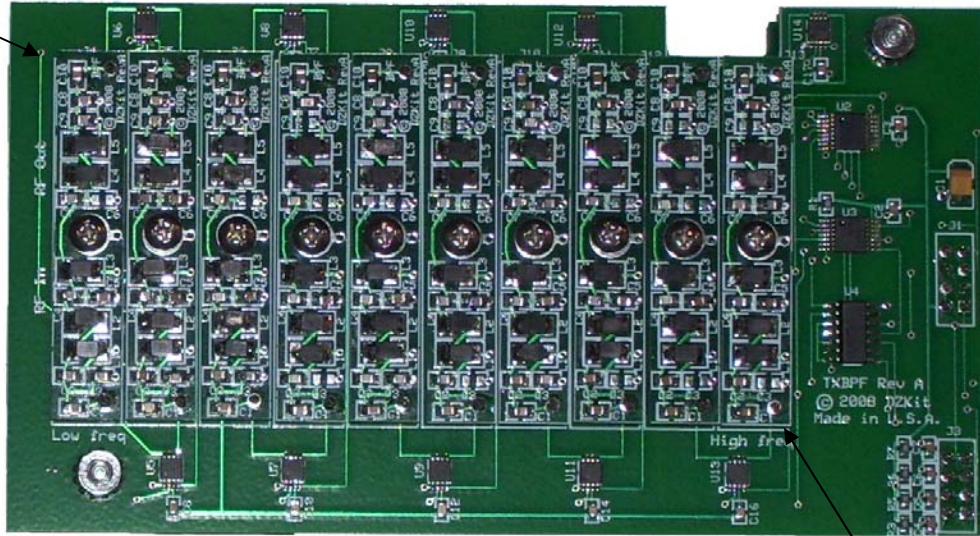

TXBPF with BPF's installed

TX10

Cut to 1/4"



Detail J1. BPF Assy



## Appendix K: Option 104: 100W PA

### PARTS LIST

Item	Part	Description	Qty
1	C58	18pF silver mica capacitor (sm)	1
1	C44	20pF sm	1
1	C53	27pF sm	1
1	C62	33pF sm	1
1	C60	47pF sm	1
1	C55	56pF sm	1
1	C50, C57	68pF sm	2
1	C63	82pF sm	1
1	C38, C47	100pF sm	2
1	C56	120pF sm	1
1	C52, C59, C61	150pF sm	3
1	C32	220pF sm	1
1	C40, C41, C54	270pF sm	3
1	C36, C37, C42, C45, C48, C49	330pF sm	6
1	C34, C46	390pF sm	2
1	C43, C51	560pF	2
1	C26, C35	1000pF sm	2
1	C31, C39	1200pF sm	2
1	C33	2200pF sm	1
2	C9	180pF monolithic capacitor	1
2	C70	1800pF 200V monolithic capacitor	1
2	C8, C12, C13	4700pF 50V monolithic	3
2	C23, C24	4700pF 200V monolithic	2
2	C22, C27, C28	.01uF monolithic	3
2	C3, C4, C5, C10, C14, C15, C16, C25, C29, C30, C64-C68	.1uF monolithic	15
2	C18, C19, C20	.1uF 200V monolithic	3
2	C17	1.0uF monolithic	1
3	C21	.01uF 500V disk ceramic capacitor	1
4	C1, C2	22uF/25V tant. electrolytic cap (SMT)	2
5	C11, C69	10uF/25V alum. electrolytic cap (SMT)	2
6	C6, C7	100uF/25V alum. electrolytic cap (SMT)	2
7	D2, D4, D5, D13	1N4007 diode (SMT)	5
7	D1	1N5231B 5.1V Zener (SMT)	1
7	D11	1N5239B 9.1V Zener (SMT)	1

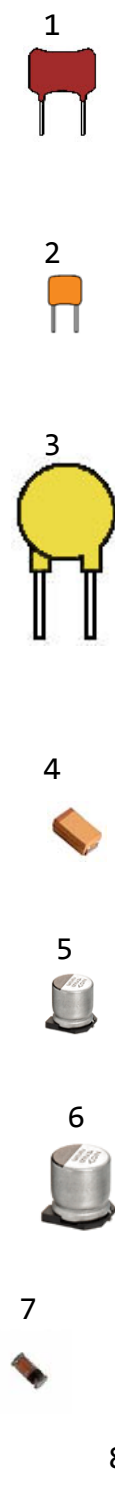



Item	Part	Description	Qty
8	D6	1N5818 diode (solid, black)	1
8	D7, D8, D9, D10	1N914 diode (glass)	4
9	D3	1N5404 diode (large)	1
10	F1	Fuse - 30A 3AG	1
11	J3	16-pin 2-row shrouded connector, right angle	1
12	J1, J7, J8	2-pin AMP MTA connector, right angle	3
13	J2, J5, J6	RF connector	3
14	K1-K13	SPDT 12V relay	13
15	L1, L2, L3, L4, L14, L15	T50-2 toroid (red)	6
16	L5-L12	T50-10 toroid (black)	8
17	L13	47uH inductor (SMT)	1
17	RFC3-7	100uH inductor (SMT)	5
18	Q5, Q10, Q11	2N3904 NPN transistor	2
18	Q1, Q4	2N7000	2
19	Q8, Q9	2SC2879A RF power transistor	2
20	Q2	FQB9N15TM power N-channel MOSFET	1
20	U6	LM2940CS-5 regulator TO-263 (SMT)	1
21	Q6, Q7	MJE182 NPN power transistor	2
22	Q3	TIP31A NPN power transistor	1
23	R10	10 ohm 1/4W metal film resistor	1
24	R7, R27	51 ohm 1/8W metal film	2
24	R20	100 ohm 1/8W metal film	1
24	R6, R8, R22, R25, R28, R38, R39	1K ohm 1/8W metal film	7
24	R21, R34	3.16K ohm 1/8W metal film	2
24	R3, R9, R31	4.7K ohm 1/8W metal film	3
24	R1, R2, R29, R33	10K ohm 1/8W metal film	4
24	R4	130K ohm 1/8W metal film	1
24	R30	1M ohm 1/8W metal film	1
24	R5	10M ohm 1/8W metal film	1
25	R19	.005 3W resistor SMT	1
26	R13, R14	2.0 2W resistor (SMT)	2
26	R11, R12	20 ohm 2W (SMT)	2

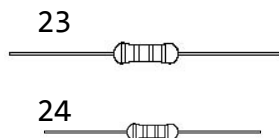
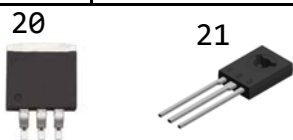
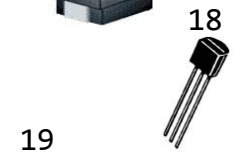
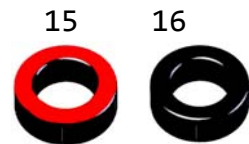
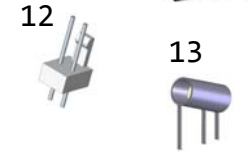
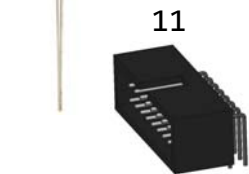
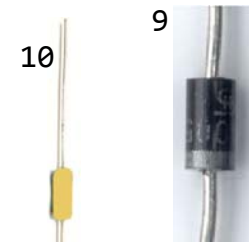



Item	Part	Description	Qty
27	R23, R24	100 ohm 1W resistor (SMT)	2
28	R15, R16, R17	10 ohm 2W metal oxide resistor	3
28	R26, R32, R35, R36, R37	47 ohm 1W metal oxide resistor	5
28	R18	300 ohm 2W metal oxide resistor	1
29	RFC1, RFC2	Ferrite Bead	2
30	RN1	Resistor network, .1" centers, 10-pin 10K	1
31	RV1	1K trimpot - side adjust	1
32	T1	Small binocular core, .5"x.75", wound 9:1CT	1
33	T2	Large binocular core, 1"x1.2", wound 1CT:16	1
34	TH1	Thermistor - 10K	1
35	U1	74HC273 octal D flip-flop	1
36	U5	LM393 dual comparator (SMT)	1
36	U3	LMC6482 dual op-amp (SMT)	1
37	U4	MAX5025 step-up DC-DC converter (SMT)	1
38	U2	ULN2803 relay driver	1
39		Thermasil sticky-back insulator	3
40		Screw - 4-40 x 3/16" PH Phillips M/S	11
41		Hex M/F spacer - 4-40 x 3/16"	4
42		Hex M/F spacer - 6-32 x 1.5"	4
43		Hex F/F spacer - 6-32 x 7/16"	1
44		Screw - 6-32 x 1/4" PH M/S	4
45		Nut - 6-32 KEPS	3
46		Fiber shoulder washer	1
47		Heatsink compound (Wakefield 4g plastic pack)	1
48	CA15	2-pin IDC cable	1
49	CA23	Ribbon cable — TUNERDATA-AMP	1
50	CA49	RF cable — AMP-TUNER	1
51		Heatsink	1
		22# magnet wire	160"
52		Blank Board	1

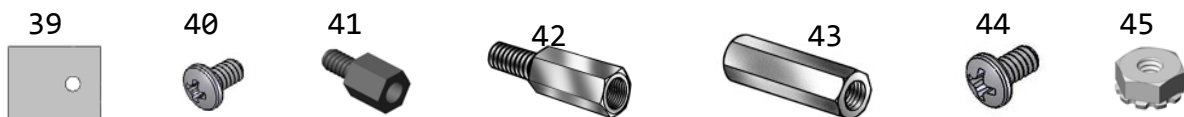
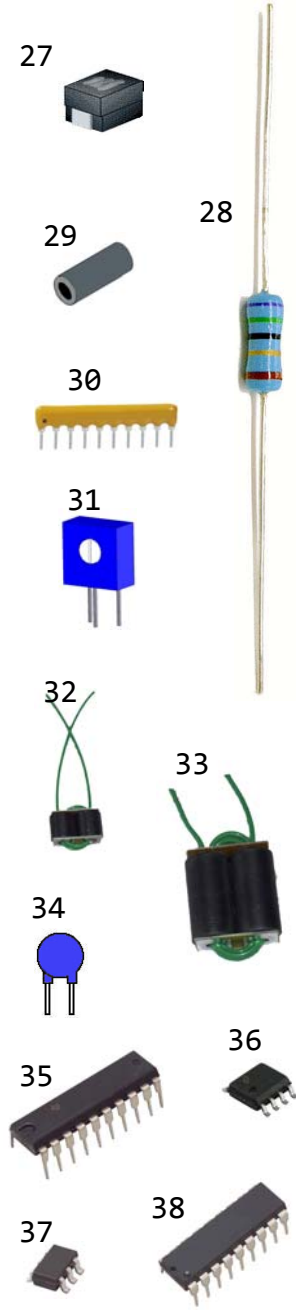



47

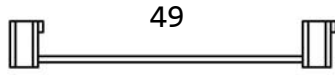

CA23



50

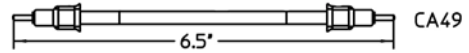

51



52

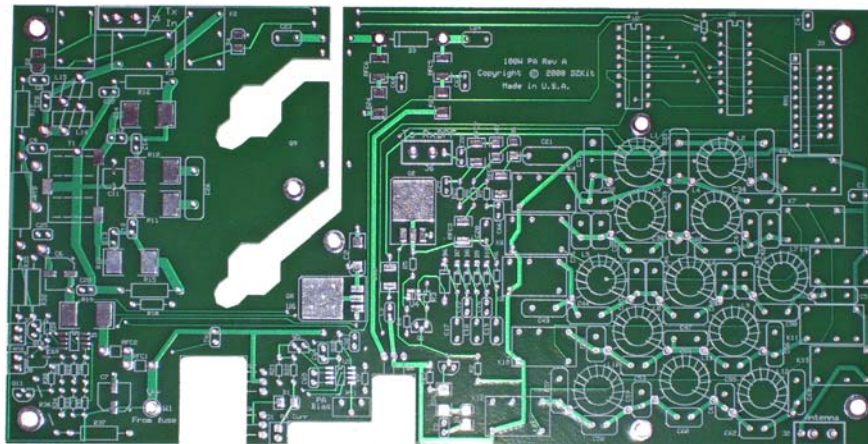



## STEP-BY-STEP ASSEMBLY-100W PA Board

When loading the following parts, locate the appropriate bag and remove only the specified parts. Check off the parts on each bag as you remove them, and then check off each step once you have completed it.

- ( ) Load and solder SMT power resistor R19.
- ( ) Load and solder SMT power resistors R11 and R12.
- ( ) Load and solder SMT power resistors R13 and R14.
- ( ) Load and solder SMT power resistors R23 and R24.
- ( ) Load and solder SMT RFCs RFC3, RFC4, RFC5, RFC6 and RFC7.
- ( ) Load and solder L13, a 47uH SMT inductor.
- ( ) Load and solder power N-channel MOSFET Q2. Be sure you install this at Q2 and not U6. The pads look the same. First, apply a small amount of solder to the center, large pad. Place this SMT part on the pads and solder one pad while holding the part to keep it from moving. Then solder the other pin(s). Some of these parts have 3 pins, some have 2. Finally, solder around the edges of the metal tab. It will be necessary to hold the soldering iron on the tab for about 30 seconds so that the solder flows evenly around and under the tab.
- ( ) Load and solder U6, a 5V regulator, in the same manner as the previous step.
- ( ) Load and solder SMT diodes D2, D4, D5, D13 (1N4007). Make sure the banded side goes on the pads marked on the silkscreen with angled corners.
- ( ) Load and solder SMT diode D1 (1N5231B), a 5.1V Zener diode.
- ( ) Load and solder SMT diode D11 (1N5239B), a 9.1V Zener diode.
- ( ) Load aluminum electrolytic SMT capacitors C6, C7, C11 and C69. Note that these are not all the same value capacitors. The body shape has angled corners. Match this with the angled corners on the silkscreen.
- ( ) Load and solder C1 and C2, 22uF tantalum electrolytic capacitors. The '+' side is marked with a line, and the silkscreen has angled corners.



- ( ) Load and solder SMT IC U4. To install this small part, use a fine tipped soldering iron and thin solder. Apply a small amount of solder to a corner pad, then place the part on the pads in the orientation shown in Detail K1. Reheat the pad that you just added solder to while holding the part in place with a small tool. Then solder the other pins one at a time, applying a very small amount of solder. Check adjacent pads carefully for shorts. If you do short out the pins, use some Solder Wick to remove the solder and try again.

Right-reading text

Dot

Pin 1

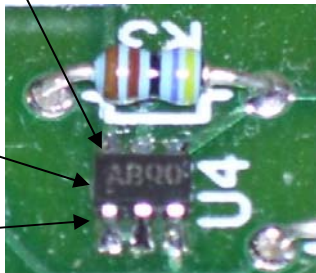

Detail K1. U4 orientation

- ( ) Load and solder SMT ICs U3 and U5 using the same technique described in the previous step.
- ( ) Load and solder resistor network RN1. Be sure that pin 1, marked with a dot, goes into the hole with the square pad.
- ( ) Load and solder all monolithic and ceramic disk capacitors. Note that these are not all the same value. Clip the leads.
- ( ) Load and solder all 1/8W, 1/4W, 1W and 2W resistors. Clip the leads. Save seven of the leads from the 2W resistors.
- ( ) Place a ferrite bead over a clipped lead from the previous step. Bend the ends of the wire down so that the resulting inductor fits in the holes for RFC1. Load and solder this part and clip the leads.
- ( ) Repeat the previous step for RFC2.
- ( ) Bend the remaining clipped resistor leads so that they fit in the five jumpers that span the vertical cut in the top center of the board. Align them carefully so they do not touch each other. Solder them in place. Clip any excess lead lengths.
- ( ) Load and solder all remaining diodes. Make sure the banded side goes on the pads marked on the silkscreen with a square pad. Clip the leads.
- ( ) Load and solder trimpot RV1. Clip the leads.
- ( ) Load and solder 2N3904 NPN transistors Q5, Q10 and Q11.



Bend the leads slightly as you insert the parts and line up the flat side with the silkscreening.

- ( ) Load and solder 2N7000 MOSFET transistors Q1 and Q4.
- ( ) Load and solder ICs U1 and U2. Be sure pin 1, marked by a notch in the IC, goes in the square pad.
- ( ) Load and solder all relays, K1-K13.
- ( ) Load and solder connector J3. Pin 1 on J3 is marked by an indented triangle. Line this up with the square pad.
- ( ) Load and solder all right angle AMP MTA connectors, J1, J7 and J8. These 2-pin connectors are mounted with the pins extending out past the edge of the board.
- ( ) Load and solder the RF connectors at J2, J5 and J6. Clip the leads.
- ( ) Cut the leads on small transformer T1 to 1/2". Strip 1/8" off the ends.
- ( ) Lay T1 on top of the board inside the silkscreened outline, with the leads facing toward the edge of the board. Note that the PC board that forms each side of the transformer has two pads on one side that line up with the pads on the 100W PA Board. On the other side, one center pad lines up with a pad on the 100W PA Board. While holding the part in place, solder one pad of the transformer to the corresponding pad on the 100W PA Board, followed by the other two. Insert the leads into the closest pads and solder them. Clip the leads. It is very difficult to remove this part once installed, so take your time and be sure that it is installed correctly.
- ( ) Repeat the above procedure for large transformer T2, mounting it on the back side of the board. Position this part as close as possible to the edge of the board while still making contact with its pads. The heatsink will be mounted very close to this part, so it is helpful to have as much clearance as possible.
- ( ) Locate the six red toroids. Cut the magnet wire into 14 lengths as shown in the table below. Wind the specified number of turns of magnet wire around each toroid. Each time the wire passes through the center is considered 1 turn. Leave about 1/2" of lead extending out from the toroid. Load these toroids into L1-L4 and L14, L15. *Mount L14 and L15 upright on the back side of the board.* Solder the leads, keeping the soldering iron (set to 750



degrees F) on the leads until the coating melts away and the solder flows onto both the pad and the wire smoothly. This can take about one minute per lead. Clip the leads.

- ( ) Repeat the previous step with the eight black toroids. Load and solder these toroids into L5-L12. Clip the leads.

L1: 27 turns (18") RED  
L2: 25 turns (17") RED  
L3: 14 turns (10") RED  
L4: 13 turns (10") RED  
L5: 13 turns (10") BLACK  
L6: 12 turns (9") BLACK  
L7: 12 turns (9") BLACK  
L8: 11 turns (8") BLACK  
L9: 10 turns (7") BLACK  
L10: 9 turns (7") BLACK  
L11: 8 turns (6") BLACK  
L12: 8 turns (6") BLACK  
L14: 31 turns (21") RED  
L15: 31 turns (21") RED

- ( ) Load and solder all silver mica capacitors. Clip the leads. The component value in

picoFarads is printed on the body of the cap. For example, a 330pF capacitor is marked 330. Ignore any suffix, such as "J".

- ( ) Insert and tighten four 4-40 x 3/16" hex male/female spacers into the four mounting holes on the heatsink as shown in Detail K1, below.

- ( ) Affix three Thermasil insulators to the heatsink as shown.

- ( ) Place Q8 and Q9 on the heatsink in the orientation shown in Pictorial K1 (Q8's collector facing up, Q9's collector facing down such that they point towards each other). The collectors have an angled cut in the fin. Insert a 4-40 x 3/16" screw into the mounting holes on each transistor and into the threaded holes on the heatsink. Secure the screws but do not tighten them.

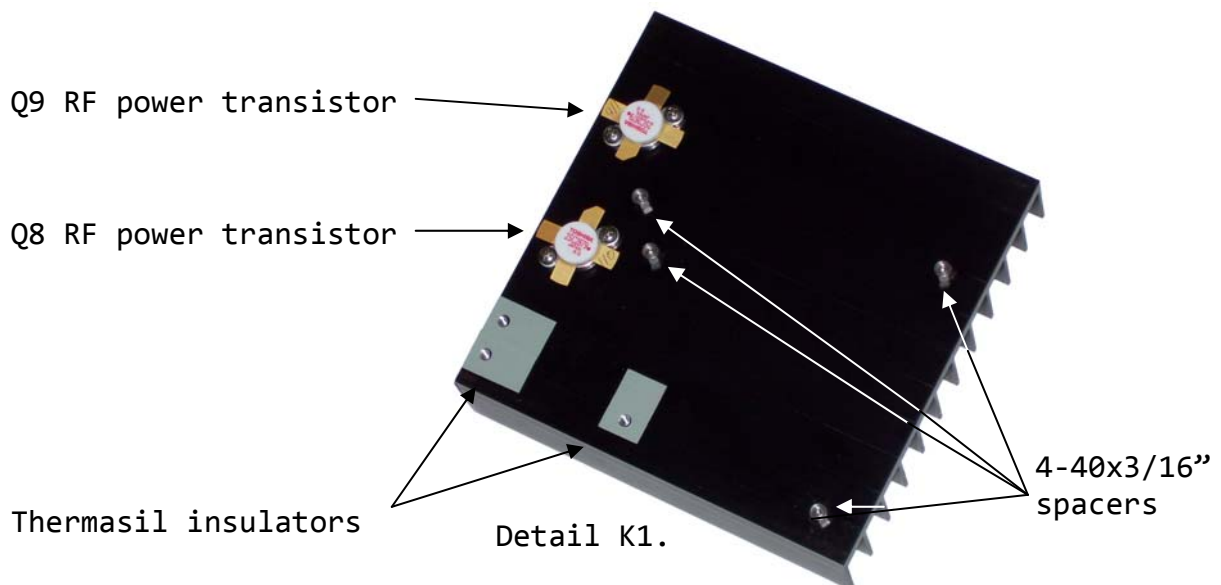



- ( ) Place the board over the heatsink, lining up the four mounting holes. Insert two 4-40 x 3/16" screws in diagonally opposite holes to keep it in place. See Detail K2.
- ( ) Solder the fin on Q8 and Q9 that is accessible (barely covered by the heatsink). It is only necessary to tack these fins in at this point, just to keep the parts from moving. See Detail K3.
- ( ) Remove the mounting screws from the heatsink and from Q8 and Q9 and remove the board.
- ( ) Solder the other three fins on Q8 and Q9. Apply plenty of solder to be sure the fins are fully attached to the pads. Re-heat the pad you tacked earlier, applying more solder if necessary. See Detail K4.
- ( ) Line up the other three transistors (Q3, Q6 and Q7) in the correct locations on the heatsink. Note where the leads of the transistors need to be bent up to fit in the PC board holes. Bend the leads up and insert them into the PC board holes from the bottom side of the board **but do not solder them.**
- ( ) Insert thermistor TH1 **from the bottom of the board.** Push it over slightly toward the center of the board, but not all the way, so that when the heatsink is attached it will compress the thermistor against the heatsink. **Do not solder it.**
- ( ) **In the next few steps you will attach the heatsink, after which the bottom of the PC board will no longer be accessible, so take a few minutes to check every solder connection! There is a virtually 100% chance that you will find a few pins unsoldered. Better to fix them now than to take the heatsink off and fix them later.**
- ( ) Apply a liberal amount of heatsink compound to the bottom metal body of Q8 and Q9.
- ( ) Lay the board onto the heatsink, being careful to line up the mounting holes.
- ( ) Re-insert the four screws into the mounting holes for Q8 and Q9 and the four PC board mounting screws.
- ( ) Insert a shoulder washer in Q3's mounting hole.
- ( ) Gently wiggle Q3, Q6 and Q7 so that their mounting holes line up perfectly with the corresponding threaded hole in the heatsink. Insert a 4-40 x 3/16" screw into the three transistor mounting holes. Make sure as you do this that the screws go in smoothly without any difficulty and that Q3's shoulder washer remains fully inserted in the transistor mounting

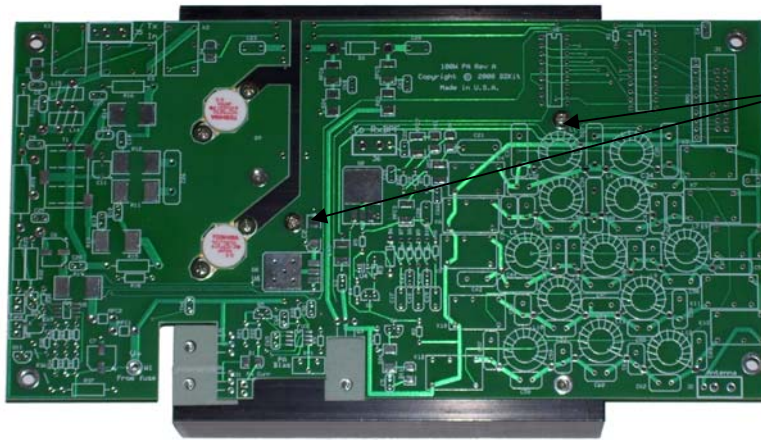

Temporary mounting screws

Detail K2.

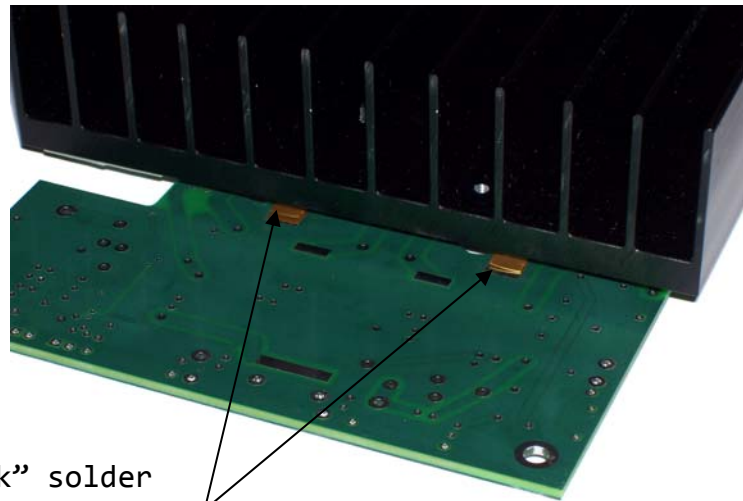

“Tack” solder  
Q8 and Q9 here

Detail K3.

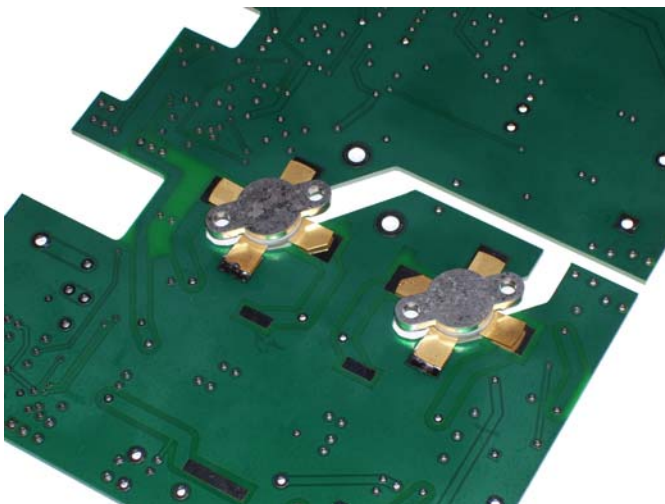

Remove heatsink and solder  
remaining pins of Q8 and Q9.

Detail K4.



hole. If you encounter resistance, back off on the screw, re-seat the washer, check to make sure the hole is centered and try again. Tighten the screws, but do not over-tighten to avoid damaging the parts.

- ( ) Solder the pins on Q3, Q6 and Q7 and clip their leads.
- ( ) Insert four 6-32 x 1 1/2" hex male-female spacers from the bottom side of the board (with the male threads pointing up) in the four corner holes of the board and attach

6-32 KEPS nuts to the top of three of the four spacers. On the spacer that is next to the RF connector marked "Antenna", use a 7/16" hex double-female threaded spacer instead of a KEPS nut.

- ( ) Push C21 (the large ceramic disk) and the large silver mica capacitors over as far as they will go. Nothing may protrude higher than .4".

This completes assembly of the 100W power amplifier.



# DZ COMPANY

LOVELAND, COLORADO

***UNIQUE ELECTRONIC EQUIPMENT IN KIT FORM***